

# Instructions

FlexVu® Explosion-Proof

Universal Display Unit

Model UD30



# Table of Contents

1.0 APPLICATION .....	1	APPENDIX H — UD30 WITH GT3000 TOXIC GAS DETECTOR.....	29
2.0 DESCRIPTION .....	1	Wiring.....	29
2.1 Magnetic Switches .....	3	Orientation .....	31
2.2 Gas Level Indication .....	3	Detector Selection .....	31
2.3 Special States.....	3	Sensor Selection .....	31
2.3.1 Access to Menus .....	4	Live Maintenance .....	31
2.3.2 Quick Access/Shortcut: Fault Menu .....	4	Calibration .....	31
2.4 Relays .....	4	APPENDIX I — UD30 WITH PIR9400 POINTWATCH .....	33
2.5 Application .....	4	Wiring.....	33
2.6 Device Display .....	4	Installation Notes .....	34
2.7 Logging .....	4	Orientation .....	34
3.0 SPECIFICATIONS.....	5	Detector Selection .....	35
4.0 IMPORTANT SAFETY NOTES .....	7	Calibration .....	35
5.0 INSTALLATION .....	7	APPENDIX J — UD30 WITH MODEL PIRECL .....	36
5.1 Identification of Vapor(s) to be Detected .....	7	Wiring.....	36
5.2 Identification of Detector Mounting Locations. .	7	Orientation .....	37
5.3 Grease/Lubrication.....	8	Detector Selection .....	37
6.0 WIRING .....	8	Calibration .....	37
6.1 Power Supply Requirements .....	8	APPENDIX K — UD30 WITH GENERIC SENSOR.....	39
6.2 Wiring Cable Requirements.....	8	Operation .....	39
6.3 Earth/Ground Bonding and Cabling.....	9	APPENDIX L — UD30 WITH FLEXSONIC .....	40
6.4 Shield Connections .....	9	Wiring.....	40
6.5 Wiring Procedure .....	9	Installation .....	40
6.6 External Reset .....	11	Operation .....	40
6.7 External Calibration.....	11	APPENDIX M — UD30 WITH PIRDUCT .....	42
7.0 SETUP WIZARD.....	11	Wiring.....	42
8.0 TROUBLESHOOTING.....	12	Installation Notes .....	43
9.0 DEVICE REPAIR AND RETURN.....	14	Orientation .....	43
10.0 ORDERING INFORMATION .....	14	Detector Selection .....	44
10.1 Accessories .....	14	Calibration .....	44
10.2 Replacement Parts.....	14	APPENDIX N — UD30 WITH LS2000.....	45
MODEL MATRIX.....	14	Wiring.....	45
APPENDIX A — FM APPROVAL .....	16	Installation .....	46
APPENDIX B — CSA CERTIFICATION.....	17	Detector Selection .....	46
APPENDIX C — ATEX APPROVAL .....	18	Calibration .....	46
APPENDIX D — IECEx APPROVAL.....	20	APPENDIX O — UD30 WITH CGS.....	48
APPENDIX E — ADDITIONAL APPROVALS .....	22	Wiring.....	48
APPENDIX F — UD30 MENU STRUCTURE .....	23	Installation .....	50
APPENDIX G — UD30 WITH HANDHELD HART COMMUNICATOR.....	28	Detector Selection .....	51
Wiring.....	28	Calibration .....	51
		K-Factor .....	52

## FlexVu® Explosion-Proof Universal Display Unit Model UD30

### IMPORTANT

*Be sure to read and understand the entire instruction manual before installing or operating the gas detection system. This product can be used with a variety of Det-Tronics gas detectors to provide early warning of the presence of a toxic or combustible gas mixture. Proper device installation, operation, and maintenance is required to ensure safe and effective operation. If this equipment is used in a manner not specified in this manual, safety protection may be impaired.*

### 1.0 APPLICATION

The FlexVu® Model UD30 is recommended for applications that require a gas detector with digital readout of detected gas levels as well as analog 4-20 mA pass-through and HART pass-through outputs and relay outputs. The UD30 Universal Display Unit is designed for use with Det-Tronics gas detectors listed in Table 1.

The display unit is designed and approved as a “stand alone” device and performs all the functions of a gas controller. When furnished with the CGS Conditioning Board, the UD30 can be used only with a CGS Sensor for detection of combustible gas. The UD30-CGS combination is certified as a “Gas Detector.”

Gas concentration and unit of measurement are indicated on a digital display. The display unit provides a linear 4-20 mA DC pass-through output signal (with pass-through HART, if available from detector) that corresponds to the detected gas concentration.

All electronics are enclosed in an explosion-proof aluminum or stainless steel housing. The display unit is used with a single detector that may be either coupled directly to the UD30, or remotely located using a sensor termination box (STB).

The UD30 features non-intrusive calibration for gas detectors. A magnet is used to perform calibration as well as to navigate the UD30's internal menu.



### 2.0 DESCRIPTION

The UD30 Universal Display can be used with various 4-20 mA gas detection devices, with or without HART. The unit provides display, output, and control capabilities for the gas detector.

The UD30 utilizes the following I/O:

Signal Inputs: 0-20 mA or 0-20 mA with HART loop from the sensing device

User Inputs: Magnetic switches (four) on the display panel

Signal Outputs: 0-20 mA pass-through. Two alarm relays and one fault relay

Visible Outputs: Backlit LCD display with five colors:  
White (Warm-up)  
Green (Normal)  
Red (Alarm/s)  
Yellow (Fault/s)  
Blue (Setup)

Gas Detection: 4-20 mA (0-100% LFL)

Table 1—Range and Default Values for UD30 Alarms and Calibration Gas Concentration

UD30 ALARM DATA				CALIBRATION
Gas Detector		High Alarm Value	Low Alarm Value	Cal Gas
ATX10	Range	N/A	N/A	N/A
	Default	20 mA	16 mA	N/A
GT3000--Hydrogen Sulfide	Range	5-90%	5-50%	30-90%
	Default	40%	10%	50%
GT3000--Ammonia	Range	5-90%	5-50%	30-90%
	Default	40%	10%	50%
GT3000--Chlorine	Range	5-90%	5-50%	30-90%
	Default	40%	10%	50%
GT3000--Hydrogen	Range	10-60%	5-50%	30-90%
	Default	40%	10%	50%
GT3000--Oxygen	Range	5-20.5% v/v	5-20.5% v/v	20.9% v/v
	Default	18% v/v	18% v/v	20.9% v/v
GT3000--Carbon Monoxide	Range	5-90%	5-50%	30-90%
	Default	40%	10%	50%
GT3000--Sulfur Dioxide	Range	5-90%	5-50%	30-90%
	Default	40%	10%	50%
GT3000--Nitrogen Dioxide	Range	5-90%	5-50%	30-90%
	Default	40%	10%	50%
PIR9400	Range	10-60%	5-50%	50%
	Default	40%	10%	50%
PIRDUCT	Range	10-60%	5-50%	50%
	Default	40%	10%	50%
PIRECL	Range	10-60%	5-50%	30-90%
	Default	40%	10%	50%
CGS Combustible	Range	10-60%	5-50%	50%
	Default	40%	10%	50%
Model 505/CGS Combustible	Range	10-60%	5-50%	N/A
	Default	40%	10%	N/A
Generic Detector	Range	N/A	N/A	N/A
	Default	40%	10%	50%
LS2000	Range	0.5-4.5 LFL-meters	0.5-4.5 LFL-meters	1.5-4.5 LFL-meters
	Default	3 LFL-meters	1 LFL-meter	2.5 LFL-meters

Notes: All values are a **percentage of full scale** with the exception of Oxygen, which is the actual percent volume of Oxygen, and model LS2000, which has the value in LFL-meters.

Low alarm must be less than or equal to the high alarm except for O2 and Generic detectors where the low alarm can be higher than the high alarm.

Changing the Measurement Range will reset all alarm and Cal Gas values to the default settings for the selected range.

Alarm relays are selectable for either normally energized or normally de-energized coils, with selectable latching or non-latching contacts. Fault relay is normally energized (with no faults), non-latching.

## 2.1 MAGNETIC SWITCHES

Four internal magnetic switches provide a non-intrusive user interface that allows navigation through the menu and adjustment of configuration parameters in the field. See Figure 1 for switch locations.

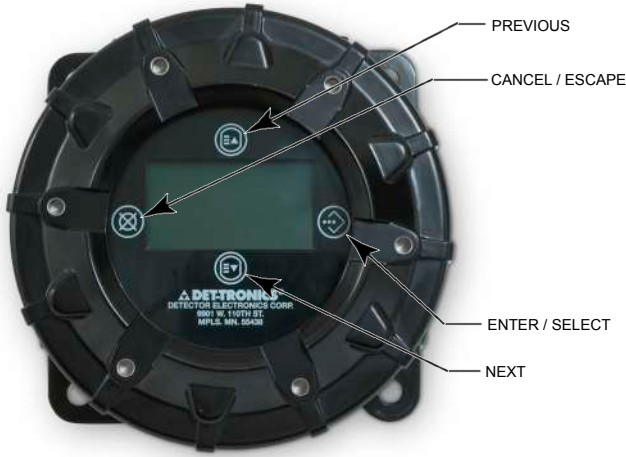

Figure 1—Faceplate of UD30

These switches are used for device configuration, checking status and event logs, and performing calibration. The switches are labeled as follows:



CANCEL / ESCAPE



ENTER / SELECT / MENU ACCESS



PREVIOUS or if on Main Screen: Fault Shortcut



NEXT

To actuate a magnetic switch, lightly touch the magnet to the viewing window of the UD30 directly over the switch icon on the faceplate.

## ⚠ CAUTION

*Handle magnets with care! Personnel wearing pacemakers/defibrillators should not handle magnets. Modern magnet materials are extremely strong magnetically and somewhat weak mechanically. Injury is possible to personnel, and magnets themselves can easily get damaged if allowed to snap towards each other, or if nearby metal objects are allowed to be attracted to the magnets.*

## NOTE

*Det-Tronics offers two magnet options for activating internal magnetic switches. The Magnetic Tool (p/n 009700-001) is the stronger magnet and is recommended for activating the switches on the UD30 viewing window. The Calibration Magnet (p/n 102740-002) is not recommended for use with the UD30.*

## 2.2 GAS LEVEL INDICATION

The UD30 display will show a plus sign “+” to the right of the indicated value (i.e., 100+%LFL, 1000+PPM), to indicate an over-range. During an under-range condition, negative gas values will be shown until the UD30 faults, then the mA value of the loop will be shown.

Actual sensor signal / gas level can be examined using display to check the device (sensor) “PROCESS VARS” > ANALOG INPUT XX.XX mA to check an actual device output. Refer to the appropriate appendix for the attached sensor type.

## 2.3 SPECIAL STATES

Special states other than warm-up, normal operation, and fault require user action for activation. This includes calibration, See Table 2.

Table 2—Special States

UD30 STATE	Gas Detector Analog Output	UD30 Display	Relays	
			Fault	Alarm(s)
Warm up	Warm up	“WARM UP”	Not Energized	Reference Table 1 Alarm Data
Normal	Normal	Gas Value, Gas Type	Energized	
Calibration	Calibration	“APPLY ZERO GAS” initially, then each calibration step	Energized	
Fault	Fault	“FAULT”	Not Energized	
Fault	Normal	“FAULT”	Not Energized	

### 2.3.1 Access to Menus

To access the menus, use the magnet to activate the ENTER/SELECT button. This will display the MAIN MENU.

Some areas of the menu contain additional information, which is indicated by the presence of an arrow on that particular line. By placing the magnet to the glass over the ENTER/SELECT button, the next screen with the additional information will be shown.

The UD30 automatically returns to the main screen after 10 minutes if no activity occurs.

### 2.3.2 Quick Access/Shortcut: Fault Menu

To access the fault menu quickly, when a fault is present, touch the magnet to the glass by the PREVIOUS button.

## 2.4 RELAYS

The display unit has three output relays — high alarm, low alarm, and fault. The relays have form C (SPDT) contacts. Low and high alarm relay contacts are selectable for latching or non-latching operation, as well as normally energized or normally de-energized (default) coils. During normal operation, the fault relay is energized. The Fault Relay is non-latching.

### IMPORTANT

*Direct connection of 120/240 VAC to the relay terminals inside the UD30 enclosure is not allowed, since switching relay contacts can induce electrical noise into the electronic circuitry, possibly resulting in a false alarm or other system malfunction. If the application requires that AC powered equipment be controlled by the transmitter, the use of externally located relays is recommended.*

External relays, solenoids, motors, or other devices that can cause inductive transients should be transient suppressed. Place a diode across the coil for DC devices. See Figure 2.

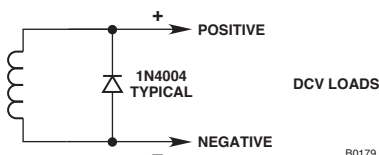

Figure 2—Transient Suppression for Inductive Loads

## 2.5 APPLICATION

The UD30 functions as a pass through device, reading the 4-20 mA DC output signal from the gas detector.

## 2.6 DEVICE DISPLAY

The UD30 is provided with a backlit LCD display. See Figure 1.

During normal operation, the LCD continuously displays the detected gas level, gas type, and units of measurement.

The display shows the following alarm information:

- High gas alarm (steady red)
- Low gas alarm (flashing red and white)

The display indicates the following fault information:

- Detector fault (steady yellow)
- Display fault (steady yellow)

The display indicates the following status information:

- Normal condition (steady green)

The UD30 has capabilities to allow easy access to the following information:

- Detector information
- Measurement range
- Alarm setpoints
- Event logs and calibration logs

## 2.7 LOGGING

Types of logs in the UD30 include:

### 1. Event Logs

Event logs include alarms (Low Gas Alarm, High Gas Alarm) and faults such as Low Signal Fault, Low Voltage Fault, etc.

### 2. Calibration

CAL OK, CAL failed, run time, and event counter number.

### 3. Temperature History Logs

Two sets of minimum and maximum temperature logs are available. One set of temperature logs can be reset in the field.

## 3.0 SPECIFICATIONS

### OPERATING VOLTAGE

24 Vdc nominal, operating range is 18 to 30 Vdc. Ripple cannot exceed 0.5 volt P-P.

## OPERATING POWER

Standard model, with heater and backlight off:

No alarm: 1.5 watts @ 24 Vdc.  
Alarm: 3 watts @ 24 Vdc (20 mA current loop output and both alarm relays energized.)

Backlight on: 0.5 watt additional @ 24 Vdc.  
Heater on: 3.5 watts additional @ 24 Vdc.

CGS Model w/ CGS Conditioning Board and CGS sensor installed:  
4 watts additional.

Maximum power in alarm, with heater and backlight on:  
7 watts @ 24 Vdc (Standard model)  
11 watts @ 24 Vdc (CGS Model).

### NOTE

*Heater turns on when the internal temperature drops below  $-10^{\circ}\text{C}$  (default operation). Heater function can be disabled to save power.*

### NOTE

*Appropriate relays will be activated when a fault or alarm occurs.*

## CURRENT OUTPUT

0-20 mA pass through. HART signals also pass through (if available). The UD30 itself is a non-HART device  
Maximum output loop resistance 600 ohms at 18 to 30 vdc.

## CURRENT OUTPUT ACCURACY: GENERAL

The UD30 adds less than 1% error to the output value. (Det-Tronics verified).

## PRESSURE RENEGE

80 kPa to 110 kPa/23.6 inHg to 32.5 inHg

## WARM-UP TIME

The UD30 waits up to 120 seconds for a normal input signal from the sensor before exiting warm-up. Recommended warm-up time is one hour.  
The CGS Model must have a 1 hour minimum warm-up before calibration, 24 hours recommended. See Appendix O for the CGS sensor.

## UNIT OF MEASUREMENT

PPM, % LFL, % or LFL-M.

## RELAY CONTACTS

Two Alarm Relays: Form C, 3 amperes at 30 Vdc.  
Selectable energized/de-energized.  
Selectable latching or non-latching.  
Refer to Table 1 for range and default settings.

## WARNING

*When in non-latching mode, the control device must latch the alarm output.*

One Fault Relay: Form C, 3 amperes at 30 Vdc.  
Normally energized for no fault condition with power applied, non-latching.

## RELAY RESPONSE TIME—

≤ 2 seconds (Det-Tronics verified).

## CGS RESPONSE TIME—

10 seconds Methane  
16 seconds Propane

## WIRING TERMINALS—

14–18 AWG, 2.5–0.75 mm<sup>2</sup> wire can be used.

## OPERATING TEMPERATURE—

$-40^{\circ}\text{C}$  to  $+75^{\circ}\text{C}$  ( $-40^{\circ}\text{F}$  to  $+167^{\circ}\text{F}$ )

## STORAGE TEMPERATURE—

$-55^{\circ}\text{C}$  to  $+85^{\circ}\text{C}$  ( $-67^{\circ}\text{F}$  to  $+185^{\circ}\text{F}$ )

## HUMIDITY RANGE—(NON-CONDENSING)

5% to 95% RH (Det-Tronics verified)  
20% to 90% RH (Performance agency verified)

## ELECTRO-MAGNETIC COMPATIBILITY—

EMC Directive 2014/30/EU  
EN 50270: 2015  
EN 61000-6-4: 2007+A1: 2011

## DIMENSIONS—

See Figure 3.

## CONDUIT ENTRIES—

3/4" NPT or M20.

## ENCLOSURE MATERIAL—

Epoxy coated aluminum or 316 stainless steel.

## SHIPPING WEIGHT—

Aluminum: 4.2 pounds (1.9 kilograms)  
Stainless Steel: 13 pounds (5.9 kilograms)

## WARRANTY—

36 months from date of manufacture.

## DETECTOR COMPATIBILITY—

The UD30 can be used with the Det-Tronics gas detectors listed in Table 3.

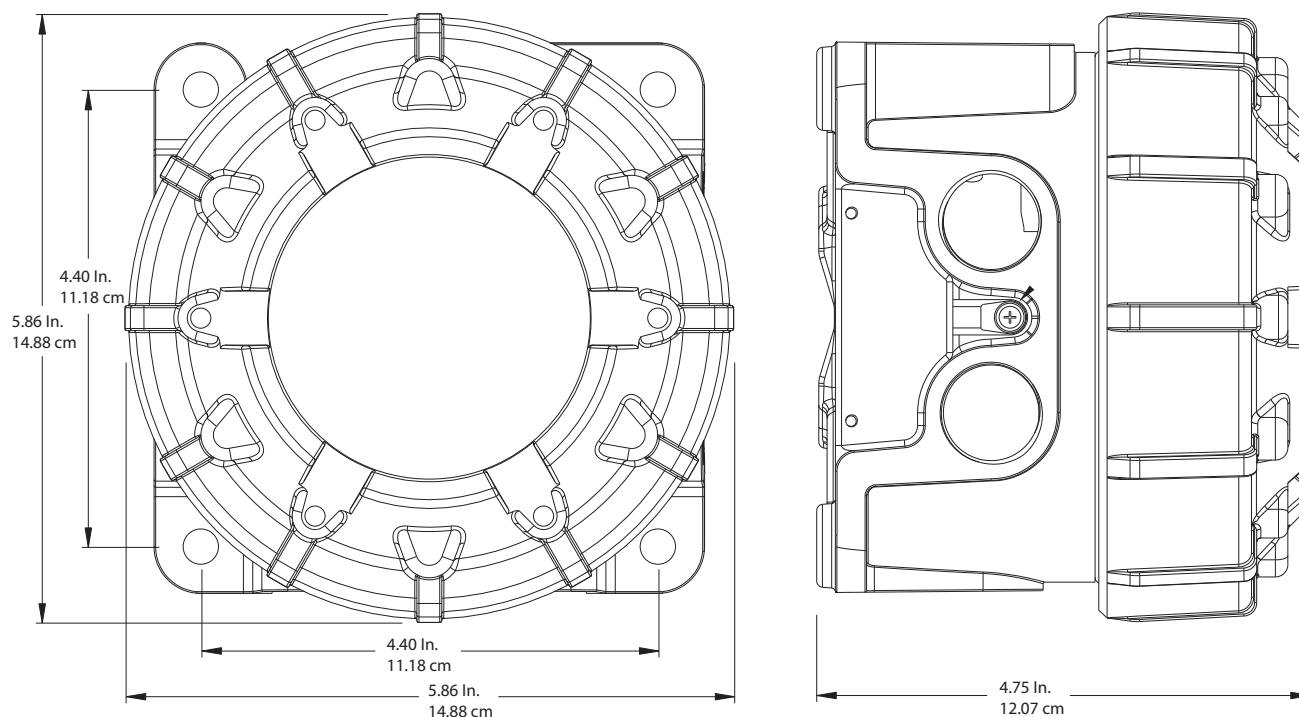

Figure 3—Dimensions of UD30

## CERTIFICATION—



For complete approval details, refer to the appropriate appendix:

Appendix A – FM

Appendix B – CSA

Appendix C – ATEX

Appendix D – IECEx

Appendix E – Additional Approvals

SIL Approval - IEC 61508  
Certified SIL 2 Capable.

For specific information regarding SIL safety certification, refer to the Model UD30 Safety Manual, number 95-8777.

Table 3—Gas Detectors Compatible with the UD30

Device	Toxic <sup>1</sup>	Catalytic Combustible	IR Combustible <sup>2</sup>	Ultrasonic Acoustic	Instruction Manual
GT3000 <sup>1</sup>	X				95-8616
PIR9400			X		95-8440
PIRDUCT			X		95-8573
PIRECL			X		95-8526
CGS		X			95-8661, 95-8764
AC100/ATX10				X	95-8657
LS2000			X		95-8714

<sup>1</sup> Hydrogen sulfide, Ammonia, Chlorine, Hydrogen, Oxygen, Carbon Monoxide, Nitrogen Dioxide, and Sulfur Dioxide.

<sup>2</sup> Hydrocarbons, see detector manual for details.



## 4.0 IMPORTANT SAFETY NOTES

### CAUTION

The wiring procedures in this manual are intended to ensure proper functioning of the device under normal conditions. However, because of the many variations in wiring codes and regulations, total compliance to these ordinances cannot be guaranteed. Be certain that all wiring complies with the NEC as well as all local codes. If in doubt, consult the authority having jurisdiction (AHJ) before wiring the system. Installation must be done by a properly trained person.

### CAUTION

This product has been tested and approved for use in hazardous areas. However, it must be properly installed and used only under the conditions specified within this manual and the specific approval certificates. Any device modification, improper installation, or use in a faulty or incomplete configuration will render warranty and product certifications invalid.

### LIABILITIES

The manufacturer's warranty for this product is void, and all liability for proper function of the detector is irrevocably transferred to the owner or operator in the event that the device is serviced or repaired by personnel not employed or authorized by Detector Electronics Corporation, or if the device is used in a manner not conforming to its intended use.

### CAUTION

Observe precautions for handling electrostatic sensitive devices.

### CAUTION

Unused conduit entries must be closed with suitably certified blanking elements upon installation.

### CAUTION

When the UD30 Universal Display is used in conjunction with an appropriate certified gas detector and configured for non-latching high alarm, the detection system must always latch and require a deliberate manual action to clear a high gas alarm.

## 5.0 INSTALLATION

### NOTE

The gas detector housing must be electrically connected to earth ground. A dedicated earth ground terminal is provided inside the UD30 housing. Please see section 6.0 for additional grounding information.

### NOTE

Refer to the Model UD30 Safety Manual (95-8777) for specific requirements and recommendations applicable to the proper installation, operation, and maintenance of SIL-Certified Model UD30 displays.

### IMPORTANT

Metric Sensors must provide five (5) threads of engagement. NPT Sensors must provide five (5) threads available.

The detector must always be installed per local installation codes.

Before installing the gas detector, define the following application details:

### 5.1 IDENTIFICATION OF VAPOR(S) TO BE DETECTED

It is necessary to identify the vapor(s) of interest at the job site. The fire hazard properties of the vapor, such as vapor density, flashpoint, and vapor pressure should be identified and used to assist in selecting the optimum detector mounting location within the area.

For cross sensitivity information, refer to each gas detector's corresponding instruction manual. Refer to Table 3 for a list of gas detectors and their corresponding instruction manuals.

### 5.2 IDENTIFICATION OF DETECTOR MOUNTING LOCATIONS

Identification of the most likely leak sources and leak accumulation areas is typically the first step in identifying the best detector mounting locations. In addition, identification of air current/wind patterns within the protected area is useful in predicting gas leak dispersion behavior. This information should be used to identify optimum detector installation points.

If the vapor of interest is lighter than air, place the detector above the potential gas leak. Place the detector close to the floor for gases that are heavier than air. Note that air currents may cause a gas that is slightly heavier than air to rise under some conditions.

Heated gases may also exhibit the same phenomenon.

The most effective number and placement of detectors varies depending on the conditions on site. The individual designing the installation must often rely on experience and common sense to determine the detector quantity and best locations to adequately protect the area. Note that it is typically advantageous to locate detectors where they are accessible for maintenance. Locations near excessive heat or vibration sources should be avoided.

Final suitability of possible gas detector locations should be verified by a job site survey.

The gas detector must be mounted with the sensor in the correct orientation as shown in Table 4.

If the UD30 faceplate is not correctly oriented, it can be rotated at 90 degree increments by pulling the electronic module from the four mounting posts that secure it to the junction box and repositioning it as desired. Note that the module is held in place by a compression fitting – no screws are involved.

### 5.3 GREASE/LUBRICATION

To ease installation and future removal, ensure that all junction box covers and sensor threads are properly lubricated. If the need arises for additional lubrication, use either Lubriplate grease (005003-001) or Teflon paste. **Avoid the use of silicone grease.**

## 6.0 WIRING

### 6.1 POWER SUPPLY REQUIREMENTS

Calculate the total gas detection system power consumption rate in watts from cold start-up. Select a power supply with adequate capability for the calculated load. Ensure that the selected power supply provides regulated and filtered 24 Vdc output power for the entire system. If a back-up power system is required, a float-type battery charging system is recommended. If an existing source of 24 Vdc power is being utilized, verify that system requirements are met. The acceptable voltage range is 18-30 Vdc measured at the input to the UD30.

#### NOTE

*When using HART detectors with the UD30 (which passes through the HART signals), the power supply must meet the noise requirements for HART systems. If noise or ripple on the main power source could interfere with the HART function, an isolated power source (Figure 8) is recommended.*

Table 4—Device Orientation

Device	Orientation
GT3000	Vertical with Sensor Pointing Down
PIR9400	Horizontal
PIRDUCT	Horizontal
CGS	Vertical with Sensor Pointing Down
PIRECL	Horizontal
AC100/ATX10	Vertical with Sensor Pointing Down
LS2000	Horizontal

*(For detailed information regarding power supply specifications, refer to the HART Communication Foundation's document "FSK Physical Layer Specification" HCF\_SPEC-54.)*

### 6.2 WIRING CABLE REQUIREMENTS

#### IMPORTANT

*All electrical connections should be made in accordance with local or national standards and building codes.*

Always use proper cabling type and diameter for input power as well as output signal wiring. 14-18 AWG, 2.5–0.75 mm<sup>2</sup> shielded stranded copper wire is recommended. Correct wire size depends on the device and wire length. Refer to the appropriate appendix for additional information. The maximum cable length from power source to UD30 is 2000 feet. Maximum cable length from UD30 to sensor/detector is 2000 feet.

#### NOTE

*The use of shielded cable in conduit or shielded armored cable is highly recommended. In applications where the wiring is installed in conduit, dedicated conduit is recommended. Avoid low frequency, high voltage, and non-signaling conductors to prevent nuisance EMI problems. Whenever possible, separate mains DC connections from I/O signals to minimize EMI conditions.*

#### CAUTION

*The use of proper conduit installation techniques, breathers, glands, and seals is required to prevent water ingress and/or maintain the explosion-proof rating. Conduit Seals not required.*

#### NOTE

*EMC / EMI testing requires bonding of the cable shield to the housing and there are to be no connections to the internal shield terminal.*

### 6.3 EARTH/GROUND BONDING AND CABLING

Proper earth/ground bonding of a system is a necessity. Among the reasons for earthing and bonding are:

1. Minimization of the effect of lightning strikes on the equipment,
2. To control or prevent the build-up of electrostatic discharges (ESD) and spark ignition,
3. Prevention voltage differences that could create a spark, capable of causing ignition, and
4. Creation of a reliable low-impedance return path for fault currents.

Effective earth/ground bonding is fundamental to ensuring good EMC and RF immunity. At the same time, the creation of earth/ground loops in the system must be avoided to prevent the risk of creating false signals.

Successful mitigation of EMC/EMI events requires evaluating the needs of the installation and combining them with a careful understanding of:

#### INSTALLATION EARTHING STRATEGY

System grounding should utilize a “STAR POINT GROUND CONNECTION”, where multiple subsystem grounds are connected to earth at a single point

#### SHIELDING TERMINATION

Termination schemes include DC, single-ended, and AC coupled. All types are dependent on component installation requirements.

#### IMPLEMENTING AN “EARTH SCREEN” TO PROTECT WIRING

The creation of an Earth Screen (essentially, a Faraday cage) protects devices against the effects of electromagnetic energy by directing unwanted energy around an installation instead of through it.

The following are required for installations requiring CE Mark compliance:

- For shielded conduit, ensure the conduit is electrically bonded to the enclosure. The enclosure must be bonded to earth ground. While internal shield connections are not required; if used, follow local building codes.
- For installations without conduit, cable with a braid or cable with braid over foil shield is required (where the braid is 85% coverage, minimum). The braid must be bonded to the housing (EMC Cable glands are required).

#### NOTE

*Det-Tronics EMC / EMI testing had the product Earthed, then used 360-degree bonding of the cable braid to the housing to create an Earth Screen. No connections to the internal shield terminal were used.*

### 6.4 SHIELD CONNECTIONS

The UD30 provides the option for termination of wiring cable shields. These connections are located on the sensor connector and the main connector, Figure 6. and are marked as “SHLD” on the product.

These shield terminals are an AC termination connected to Earth. They are capacitively coupled connected to Earth ground internal to the product. These terminations provide a high-frequency connection to Earth ground while preventing DC ground loops.

#### IMPORTANT

*The rule to follow is “Shields connected to enclosure. No shield (‘drain’) wire connections are needed.*

The following are required for installations requiring CE Mark compliance:

- For shielded conduit, ensure the conduit is electrically bonded to the enclosure. The enclosure must be bonded to earth ground. While internal shield connections are not required; if used, follow local building codes.
- For installations without conduit, cable with a braid over foil shield is required (braid is 85% coverage, minimum). The braid must be bonded to the case (EMC Cable glands are required).

### 6.5 WIRING PROCEDURE

#### NOTE

*Figure 7 shows the output of the UD30 wired to a generic 4-20 mA signal receiver. Since the UD30 can be used with a variety of different detection devices, information that is specific to each detector model (wiring, calibration, display menus, etc.) is covered in an appendix that is dedicated to that device. Refer to the appropriate appendix in this manual for specific information when wiring the detection system. For information on devices not covered in an appendix, refer to the manual provided by the device’s manufacturer.*

Figure 6 shows the wiring terminals on the UD30 Display Module. Figure 7 shows a UD30 Wired to a PLC

# UD30 Display Unit

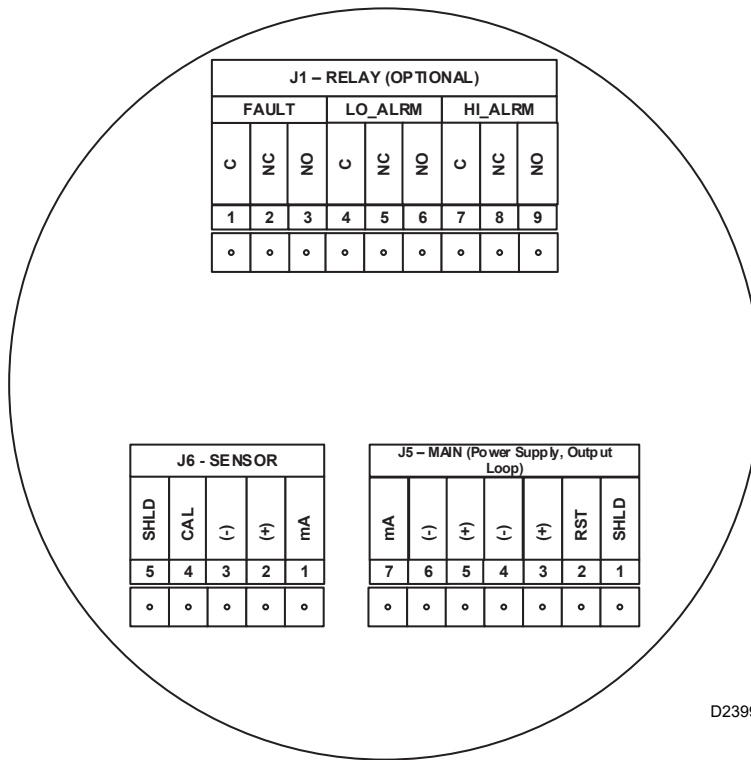

D2399

Figure 6—Wiring Terminals on UD30 Display Module

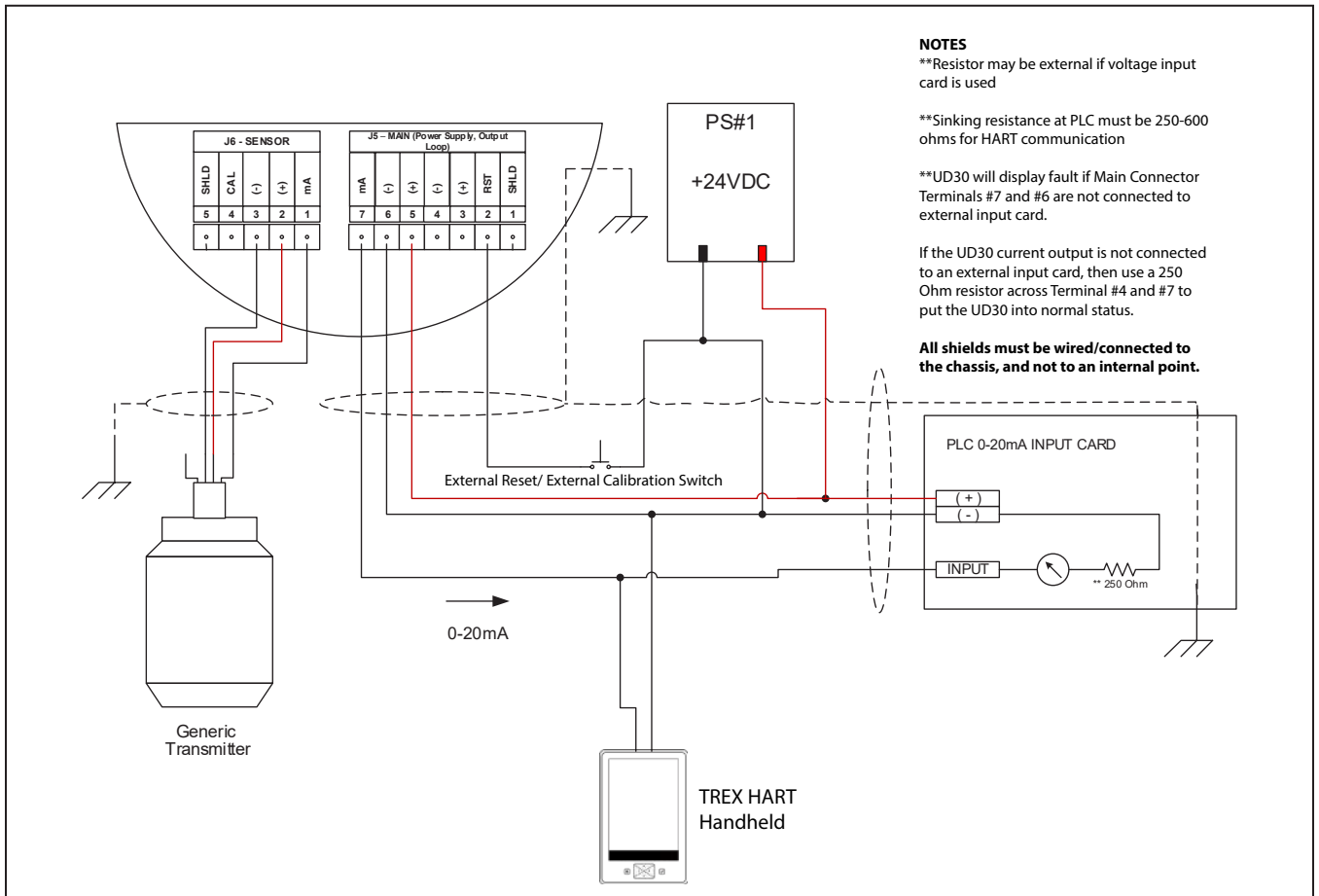

Figure 7—UD30 Wired to PLC using 3-Wire Shielded Cable with 0-20 mA Non-Isolated Sourcing Output

using 3-Wire Shielded Cable with a 4-20 mA Non-Isolated Sourcing Output.

### 6.6 EXTERNAL RESET

The UD30 provides a terminal (“RST” terminal on main connector) for connecting an external switch (Figure 7) that can be used to remotely reset latched alarm relays or initiate sensor calibration remotely. Latched alarm relays are reset when the RST Line is connected to -VDC for 1 second. The RST Line should be disconnected from -VDC after the Alarm Relays have been unlatched.

### 6.7 EXTERNAL CALIBRATION

Calibration can be initiated from the main menu. Alternately, the user may opt to initiate via the external RST line as described below.

The RST line also functions as a Calibration Initiation Line if the UD30 External Cal function is enabled and the detector connected to the UD30 has an External Calibration wire. To enable this feature select “ENABLED” from the SETUP>EXTERNAL CAL menu. **The RST Line must be connected to -VDC for 1 second to initiate a Latched Alarms RESET function. The RST Line must be connected to -VDC for a minimum of 8 seconds for the UD30 to initiate calibration on the attached gas detector.**

**While in the Gas Calibration State and at the APPLY GAS/SPAN CALIBRATION step if the RST line is released and connected to -VDC for a minimum of 8 seconds, the gas calibration will be aborted.** If there are Latched Alarms and the RST Line is connected to -VDC, the latched alarm relays will reset after 1 second. If the RST Line is continued to be held at -VDC, after 8 seconds the UD30 will initiate a gas detector calibration. After Resetting the Alarm Relays/Initiating Calibration, the RST Line should be disconnected from -VDC.

### 6.8 UD30 TO CGS CONNECTION

A factory installed cable (Figure 71.) is used to connect the UD30 Display to the UD30 CGS Board.

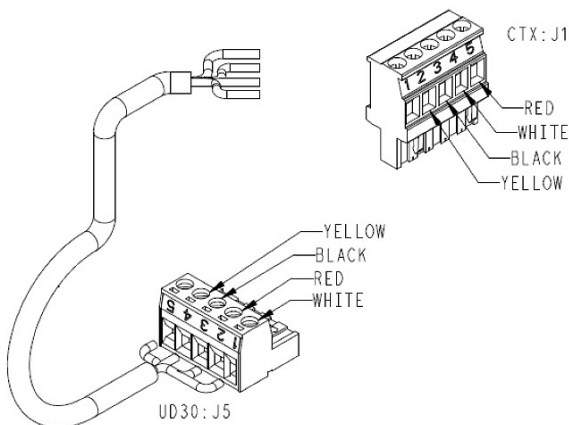

Figure 7.1 - UD30 Display to UD30 CGS Board

### Connector Details

UD30-J5	CTX10-J1	CABLE 4 POS	FUNCTION
14486-005	102988-028	010250-001	
PIN 1	PIN 5	WHITE	4-20 mA OUTPUT
PIN 2	PIN 4	RED	+ 24 VDC In
PIN 3	PIN 3	BLACK	24 VDC Com
PIN 4	PIN 2	YELLOW	EXT
PIN 5	PIN 1	(n/a)	SHLD

### 7.0 SETUP WIZARD

After power has been applied and the warm-up period is complete, configure the UD30 for the attached detector. To do this:

1. Access the MAIN MENU by touching the magnet to the ENTER/SELECT button. From there, navigate to the SETUP WIZARD menu.

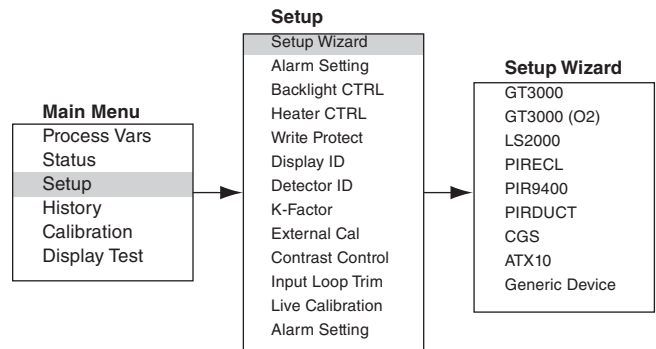

2. After selecting the type of detector, the SETUP WIZARD leads the user through the following selections:

#### NOTE

*The backlight will turn blue when a new detector type is selected, indicating the SETUP WIZARD is active. Once initiated, the SETUP WIZARD must be completed and cannot be exited using ESC.*

#### NOTE

*Changing the gas type on the UD30 does not change the gas type at the detector. Please refer to the specific detector manual for configuration changes.*

3. If the detector is replaced with another detector type, configure the detector using the SETUP WIZARD to ensure that correct information is displayed.

### 8.0 TROUBLESHOOTING

If a Fault condition is indicated on the UD30 faceplate, the nature of the fault can be determined by using the magnetic tool to navigate to the appropriate Fault screen.

**Shortcut:** From the main display screen, touch the magnet to the “Previous” switch to go directly to the Fault screen.

*Example:*

For a Display (UD30) related fault:  
 MAIN MENU > STATUS > DISPLAY FAULTS > FAULT

For a Detector related fault:  
 MAIN MENU > STATUS > DETECTOR FAULTS > FAULT

When the active fault has been identified, refer to Table 5 - Troubleshooting Guide for a description of the fault and suggested corrective action.

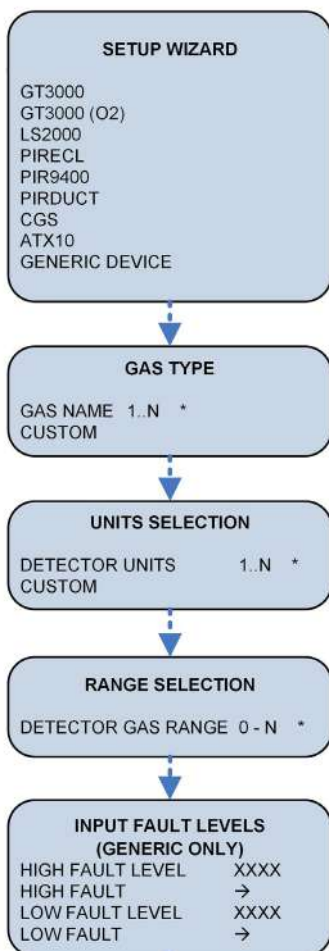

## 9.0 DEVICE REPAIR AND RETURN

Prior to returning devices, contact the nearest local Detector Electronics office or visit the Det-Tronics website (www.Det-Tronics.com) so that a Return Material Authorization (RMA) number can be assigned. **A written statement describing the malfunction must accompany the returned device or component to assist and expedite finding the root cause of the failure.**

Pack the unit properly. Always use sufficient packing material. Where applicable, use an antistatic bag as protection from electrostatic discharge. The RMA number should be clearly marked on the outside of the box.

### NOTE

*Inadequate packaging that ultimately causes damage to the returned device during shipment will result in a service charge to repair the damage incurred during shipment.*

Return all equipment transportation prepaid to the factory in Minneapolis.

### NOTE

*It is highly recommended that a spare be kept on hand for field replacement to ensure continuous protection.*

Table 5—Troubleshooting Guide - UD30 Display Messages

Display Faults/Logs		
Display Message	Description	Recommended Action
LOW CAL LINE ON	Cal line wire is shorted	Verify wiring is correct.
FLASH FAULT ON	FLASH memory fault	Cycle power to the unit. If problem does not clear, return UD30 to factory.
FIRMWARE FAULT ON	Internal software control problem	Cycle power to the unit. If problem does not clear, return UD30 to factory.
INPUT VOLTAGE	This fault will log 1 of 2 events: 24V LO FLT ON (voltage < 18 VDC) or 24V HI FLT ON (voltage > 31 VDC)	Verify device is receiving voltage in the range 18VDC to 31 VDC. Check power wiring and output voltage of power supply.
FLASH CRC FLT ON	Calculated FLASH CRC does not match stored value	Cycle power to the unit. If problem does not clear, return UD30 to factory.
RAM FLT ON	RAM check failed	Cycle power to the unit. If problem does not clear, return UD30 to factory.
WDT FLT ON	WDT test failed	Watchdog timer not functioning. Return UD30 to factory.
5.5V FLT ON	5.5v supply is outside of range	Return UD30 to factory.
INPUT LOOP FLT ON	Input loop current is outside of range	Check wiring. Calibrate sensor.
EXT RST LINE FLT ON	External reset line was shorted to -VDC on boot-up	Check wiring. Power must be cycled to clear this fault.
POWER UP	Power to the display was restored	N/A
BANK 1 REPAIRED	CRC check of configuration data bank 1 failed and was restored	N/A
BANK 2 REPAIRED	CRC check of configuration data bank 2 failed and was restored	N/A
SETUP WIZARD USED	The detector type was changed using the SETUP WIZARD	N/A
LOW ALARM CHANGED	The low alarm level was changed	N/A
HIGH ALARM CHANGED	The high alarm level was changed	N/A
RESET LATCHES	A latched alarmed event occurred, and the system was reset	N/A
TEMP SENSOR FAULT	Internal temperature sensor failed	Not field repairable. Return UD30 to factory.
GENERAL FLT ON	Eclipse bundles faults such as internal PS failures and FLASH CRC, RAM error into this fault	Cycle power to detector that is connected. Return detector to factory if cycling power does not resolve the issue.
LOW SIGNAL FLT ON	LS2000 receiver reports a low signal	Check that optics are clean and units are properly aligned.
SD CARD FLT ON	Acoustic detector reports an SD card fault	Verify the specific SD card fault at the ATX10 via HART or the Acoustic Inspector software.
CGS COMM FAULT ON	CGS detector reports a cal-line comm fault	Verify wiring.
LOOP FAULT ON	CPU failure reported (0mA)	Check 4-20 loop wiring for shorts or opens.
WARMUP ON	Sensor is warm-up mode	N/A
SENSOR FAULT ON	Attached sensor is reporting a fault	Verify specific fault at the detector.
REF SNSR FLT ON	Reference channel fault	Return detector to factory.
ACT SNSR FLT ON	Active channel fault	Return detector to factory.
CAL STARTUP ON	The cal-line was grounded on power-up	Ensure cal-line wiring is not shorted.
LOW VOLTAGE ON	The sensor reports an input voltage fault	Verify proper voltage to detector.
OPTICS FAULT ON	A blocked optics fault is being reported	Perform cleaning procedure as described in the detector manual, then perform calibration.
CAL FAULT	The last calibration operation failed	Verify wiring and recalibrate. Check detector specific manual if necessary.
ZERO DRIFT FAULT ON	Detector's sensor is reporting negative drift	Detector may have been zero calibrated with background present. Recalibrate sensor.
LOW FAULT ON	Input loop current value below specified limit	Verify correct sensor type and calibration.
HIGH FAULT ON	Input loop current value above specified limit	Verify correct sensor type and calibration.

**Note:** A fault condition will cause an oxygen detector to generate an alarm output as the decreasing 4-20 mA signal passes through the alarm range.

## 10.0 ORDERING INFORMATION

Refer to the UD30 Model Matrix for ordering details.

### 10.1 ACCESSORIES

Part Number	Description
009700-001	Magnetic Tool
005003-001	Lubriplate grease, 1 oz.
101197-001	Stop Plug, 3/4" NPT, AL
101197-006	Stop Plug, M20, AL, IP66
101197-007	Stop Plug, M20, SS, Domed
101197-004	Stop Plug, 3/4" NPT, SS
102804-001	Reducer, M25 to M20, AL

### 10.2 REPLACEMENT PARTS

Part Number	Description
014028-001	UD30 Display Module No Relays
014028-002	UD30 Display Mod with Relays

## UD30 MODEL MATRIX

MODEL	DESCRIPTION	
UD30	FlexVu® UD30 Universal Display	
	TYPE	DETECTOR HOUSING MATERIAL
	A	ALUMINUM (STANDARD)
	S	STAINLESS STEEL
	TYPE	PORT
	3	3 Port, T-Configuration (STANDARD)
	TYPE	THREAD
	F	Metric M20
	M	Metric M25
	N	3/4" NPT
	TYPE	OUTPUT
	12	4-20 mA Pass-Through* / HART Pass-Through*
	13	Relay, 4-20 mA Pass-Through* / HART Pass-Through*
	TYPE	APPROVALS**
	SA	SIL/FM/CSA
SE	SIL/ATEX/IECEX	
TYPE	CLASSIFICATION	
2	Division/Zone Ex d	
TYPE	OPTIONAL CONDITIONING BOARD	
C	CGS	

\* The UD30 does not communicate via HART but will pass through, without interference, any HART signals present on the 4-20mA line. \*The UD30 also passes through the 4-20mA detector input to the UD30 4-20mA output terminals.

\*\* Type Approvals can use one or more letters to designate the approvals of the product.



# APPENDICES

# APPENDIX A

## FM APPROVAL

FM18US0216X  
Class I, Div. 1, Groups B, C & D (T5);  
Class I, Div. 2, Groups A, B, C & D (T4);  
Tamb -40°C to +75°C  
Type 4X (UD30)  
Type 3R (UD30 CGS)  
Conduit seal not required.

Performance verified in accordance with:

**UL FM 60079-29-1: 2019**

ANSI/ISA 60079-29-1: 2013  
ANSI/ISA-92.00.01: 2010  
ANSI/ISA-12.13.04: 2007  
FM 6320 (2018)  
FM 6325 (2005)  
FM 6340 (2014)  
ANSI/NEMA 250: 2014

This approval does not include or imply approval of gas detector heads or other apparatus to which the subject instrument may be connected. In order to maintain a Factory Mutual Research approved system, the measurement input signal to which this instrument is connected must also be approved by Factory Mutual Research.

UD30 hazardous location and performance testing was successfully completed down to -40°C.

**NOTE**

*Consideration must be given to overall Gas System Performance Requirements.*

 **WARNING**

*When a sensor/detector is connected directly to the UD30 housing, the lower ratings of the two devices will prevail.*

**Special Conditions for Safe Use:**

1. The Universal Display Unit Model UD30 complies with FM 6320, ANSI/ISA 60079-29-1, FM 6340, ANSI/ISA-92.00.01, FM 6325, and ANSI/ISA-12.13.04 only when connected to a gas detector that also has been evaluated to the appropriate standard listed above.
2. Flameproof joints are not user serviceable; contact the manufacturer for details.

## APPENDIX B

### CSA CERTIFICATION

CSA 70192215  
CSA C22.2 No. 30  
Class I, Div. 1, Groups B, C & D (T5);  
Class I, Div. 2, Groups A, B, C & D (T4);  
(Tamb = -40°C to +75°C)  
Type 4X for UD30  
Type 3R for UD30 CGS

Performance verified in accordance with:  
CSA No. 60079-29-1: 2017

#### NOTE

*Consideration must be given to overall Gas System Performance Requirements.*

#### **WARNING**

*When a sensor/detector is connected directly to the UD30 housing, the lower ratings of the two devices will prevail.*

#### **WARNING**

*Do not open when an explosive atmosphere may be present.*

#### **ATTENTION**

*Ne pas ouvrir quand une atmosphère explosive peut être présente.*

#### NOTE

*Conduit seal not required.*

#### REMARQUE

*Joint de conduit non requis.*

## APPENDIX C

### ATEX APPROVAL

#### FLEXVU® EXPLOSION-PROOF UNIVERSAL DISPLAY UNIT MODEL UD30

DEMKO 18 ATEX 2008X  
Ⓔ II 2 G  
Ex db IIC T5 Gb  
EN 60079-29-1  
T5 Ambient –40°C to +75°C  
IP66 for UD30  
IP53 for UD30 CGS

Performance verified in accordance with:  
EN 60079-29-1: 2016

Compliance with:  
EN 60079-0: 2012+A11:2013  
EN 60079-1: 2014

**Note:** wire must be rated for +93C to comply with EN 60079-0.

#### Special Conditions for Safe Use:

1. The UD30 control unit complies with EN 60079-29-1 only when connected to a Detector Head that also has been evaluated to EN 60079-29-1.
2. Response time is determined by the response time of all parts of the gas detection system.
3. Flameproof joints are not intended to be repaired.

#### NOTE

*Consideration must be given to overall Gas System Performance Requirements.*

#### WARNING

*When a sensor/detector is connected directly to the UD30 housing, the lower ratings of the two devices will prevail.*

#### CATALYTIC COMBUSTIBLE GAS SENSOR (CGS)

Ⓔ 0539 Ⓔ II 2 G  
Ex db IIC T3, T5 Gb EN60079-29-1  
DEMKO 02 ATEX 131323X  
T5 (Tamb = –40°C to +75°C)  
T3 (Tamb = –55°C to +125°C).

EN Standards: EN 60079-0: 2012+A11: 2013  
EN 60079-1: 2014  
EN 60079-29 -1: 2007

#### Special Conditions for Safe Use of CGS:

The CGS Combustible Gas Sensor is certified for use in following ambient temperatures:

- ambient temperature range –40°C to +75°C.

Coding: **Ex db IIC T5 Gb**

- ambient temperature range –55°C to +125°C.

Coding: **Ex db IIC T3 Gb**

The actual temperature range is marked on the sensor.

The performance ambient temperature rating is limited to  $-40^{\circ}\text{C}$  to  $+75^{\circ}\text{C}$ .

The CGS Combustible Gas Sensor can withstand repeated exposures to  $125^{\circ}\text{C}$  for periods up to 12 hours. It is recommended that the sensor be replaced after maximum 500 hours of exposed to the  $125^{\circ}\text{C}$  temperature condition.

The CGS Combustible Gas Sensor must be used in conjunction with the before mentioned ATEX certified Detector Electronics Corp. combustible gas detector control units for compliance with EN 60079-29-1 standards.

The CGS Combustible Gas Sensor must only be mounted into the enclosures of the Infiniti Gas Transmitter Model U9500A Series, the UD10 and UD30 Universal Displays, the Combustible Gas Transmitter Model CTX10 Series, the Digital Communication Unit EQ 22xxDCUEx Series or the Sensor Termination Box Model STB Series.

The actual enclosure must provide a maximum measured reference pressure of 15 bar measured according to EN 60079-1: 2014, §15.

The CGS Combustible Gas Sensor is to be installed in places where there is a low risk of mechanical damage. Flameproof joints are not user serviceable; contact Det-Tronics Service.

### **SENSOR TERMINATION BOX (STB)**

CE 0539 Ⓢ II 2 G

Ex db IIC T4-T6 Gb EN60079-29-1

DEMKO 02 ATEX 131324X

T6 ( $T_{amb} = -55^{\circ}\text{C}$  to  $+60^{\circ}\text{C}$ ).

T5 ( $T_{amb} = -55^{\circ}\text{C}$  to  $+75^{\circ}\text{C}$ ).

T4 ( $T_{amb} = -55^{\circ}\text{C}$  to  $+125^{\circ}\text{C}$ ).

IP66.

EN Standards: EN 50270: 2006  
EN 60079-0: 2012+A11: 2013  
EN 60079-1: 2007  
EN 60529: 2001  
EN 60529: 1991+A1: 2000  
EN 60079-29-1: 2007

### **Special Conditions for Safe Use (Sensor Termination Box):**

The Sensor Termination Box model STB has an ambient temperature rating for performance of  $-55^{\circ}\text{C}$  to  $+75^{\circ}\text{C}$ .

## APPENDIX D

### IECEX APPROVAL

#### FLEXVU® EXPLOSION-PROOF UNIVERSAL DISPLAY UNIT MODEL UD30

IECEX UL 18.0009X  
Ex db IIC T5 Gb  
IEC 60079-29-1: 2016  
T5 Ambient  $-40^{\circ}\text{C}$  to  $+75^{\circ}\text{C}$   
IP66 for UD30  
IP53 for UD30 CGS

Performance verified in accordance with:  
IEC 60079-29-1: 2016

Compliance with:  
IEC 60079-0: 2011-16  
IEC 60079-1: 2014  
IEC 60529, 2.1 ed + Corr. 1: 2003 + 2: 2007

**Note:** wire must be rated for +93C to comply with IEC 60079-0.

#### Special Conditions for Safe Use:

1. Response time is determined by the response time of all parts of the gas detection system.
2. Flameproof joints are not intended to be repaired.
3. The UD30 control unit complies with IEC 60079-29-1 only when connected to a Detector that also has been evaluated to IEC 60079-29-1.

#### NOTE

*Consideration must be given to overall Gas System Performance Requirements.*



Warning

When a sensor/detector is connected directly to the UD30 housing, the lower ratings of the two devices will prevail.

#### CATALYTIC COMBUSTIBLE GAS SENSOR (CGS)

IECEX ULD 10.0001X  
Ex db IIC T3, T5 Gb  
T5 (Tamb =  $-40^{\circ}\text{C}$  to  $+75^{\circ}\text{C}$ )  
T3 (Tamb =  $-55^{\circ}\text{C}$  to  $+125^{\circ}\text{C}$ ).

IEC Standards: IEC 60079-0: 2011  
IEC 60079-1: 2014

#### CONDITION OF CERTIFICATION:

- The CGS Combustible Gas Sensor is certified for use in following ambient temperatures:
- ambient temperature range  $-40^{\circ}\text{C}$  to  $+75^{\circ}\text{C}$ .  
Coding: **Ex db IIC T5 Gb**
  - ambient temperature range  $-55^{\circ}\text{C}$  to  $+125^{\circ}\text{C}$ .  
Coding: **Ex db IIC T3 Gb**

The actual temperature range is marked on the sensor.

The CGS Combustible Gas Sensor can withstand repeated exposures to  $125^{\circ}\text{C}$  for periods up to 12

hours. It is recommended that the sensor be replaced after maximum 500 hours of exposed to the 125°C temperature condition.

The CGS Combustible Gas Sensor must only be mounted into the enclosures of the Infiniti Gas Transmitter Model U9500A Series, the UD10 and UD30 Universal Displays, the Combustible Gas Transmitter Model CTX10 Series, the Combustible Gas Transmitter Model 505 Series, the Digital Communication Unit EQ 22xxDCUEx Series or the Sensor Termination Box Model STB Series.

The actual enclosure must provide a maximum measured reference pressure of 15 bar measured according to IEC 60079-1: 2007, §15.

The CGS Combustible Gas Sensor is to be installed in places where there is a low risk of mechanical damage.

Flameproof joints are not user serviceable; contact Det-Tronics Service.

### **SENSOR TERMINATION BOX (STB)**

IECEX ULD 10.0007  
Ex db IIC T4–T6 Gb  
T6 (T<sub>amb</sub> = -55°C to +60°C).  
T5 (T<sub>amb</sub> = -55°C to +75°C).  
T4 (T<sub>amb</sub> = -55°C to +125°C).  
IP66.

IEC Standards: IEC 60079-0: 2011  
IEC 60079-1: 2007  
IEC 60529, 2.1.ed.+Corr. 1: 2003+2: 2007

### **Special Conditions for Safe Use (Sensor Termination Box):**

The Sensor Termination Box model STB has an ambient temperature rating for performance of -55°C to +75°C.

## **APPENDIX E**

### **ADDITIONAL APPROVALS**

INMETRO Brazil  
UL-BR 21.0943X  
Ex db IIC T5 Gb  
IEC 60079-29-1: 2016  
T5 Ambient -40°C to +75°C  
IP66 for UD30  
IP53 for UD30 CGS



# APPENDIX F

## F.1 UD30 MENU SYSTEM

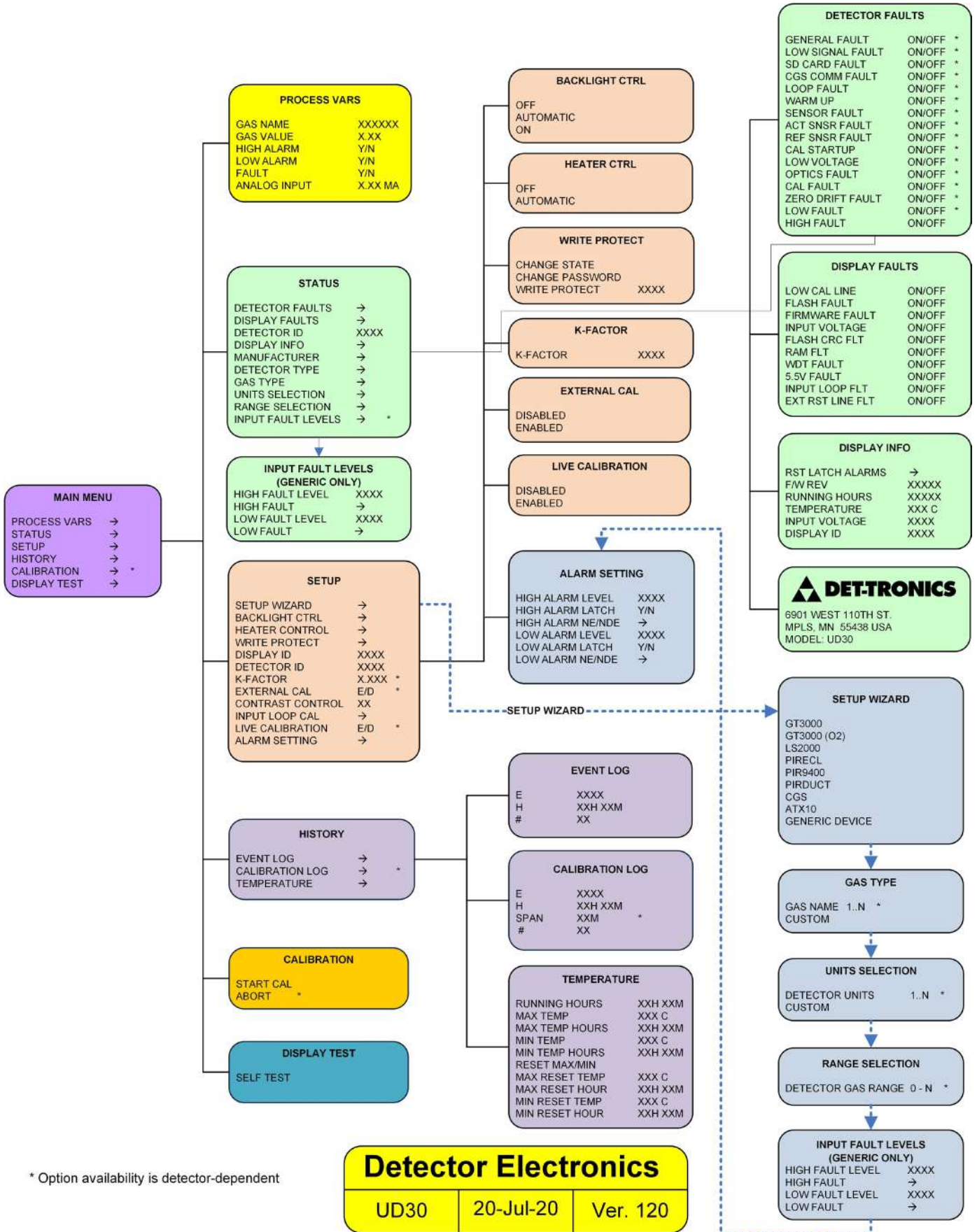

\* Option availability is detector-dependent

Detector Electronics		
UD30	20-Jul-20	Ver. 120









# APPENDIX G

## USING A HANDHELD HART DEVICE CONNECTED TO THE UD30'S 4-20 MA OUTPUT (UD30 WITH ANY DETECTOR)

### NOTE

Refer to the front of this manual for complete information regarding installation, wiring, and startup of the UD30.

## WIRING

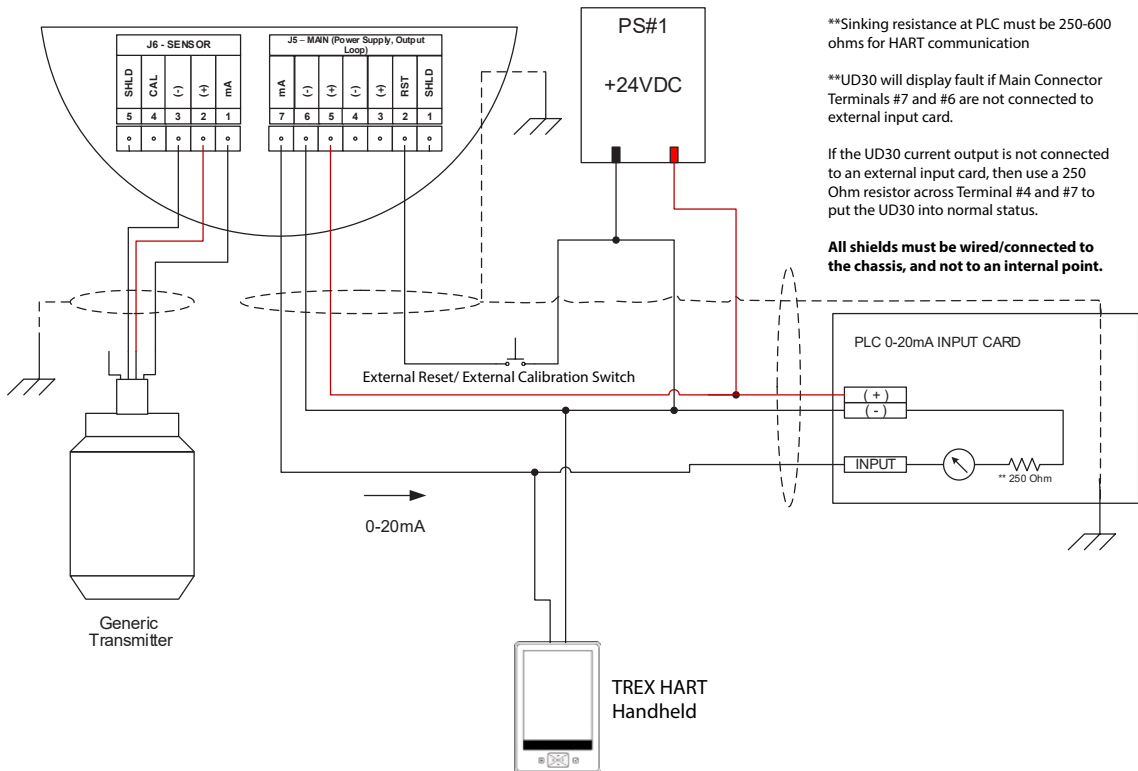

### NOTES

\*\*Resistor may be external if voltage input card is used

\*\*Sinking resistance at PLC must be 250-600 ohms for HART communication

\*\*UD30 will display fault if Main Connector Terminals #7 and #6 are not connected to external input card.

If the UD30 current output is not connected to an external input card, then use a 250 Ohm resistor across Terminal #4 and #7 to put the UD30 into normal status.

**All shields must be wired/connected to the chassis, and not to an internal point.**

Figure 8 – HART Handheld Communicator Connected to the UD30's 4-20 mA Output

### IMPORTANT

To ensure proper operation of the HART communication system, a power supply with low noise and ripple must be used. If noise or ripple on the main power source could interfere with the HART function, an isolated power source is recommended. For additional information, refer to "Power Supply Requirements" in the "Wiring" section of this manual.

# APPENDIX H

## UD30 with GT3000 TOXIC GAS DETECTOR

### NOTE

For complete information regarding the GT3000 Gas Detector, refer to instruction manual 95-8616.

## WIRING

## ORIENTATION

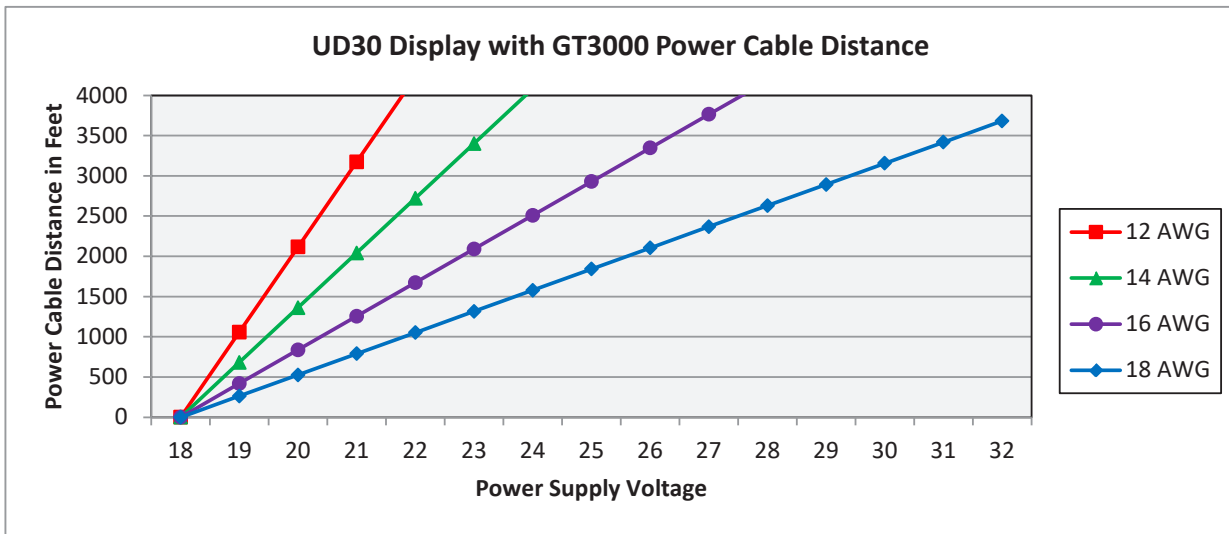

Notes: Maximum recommended cable length from power source to UD30 is 2000 feet.  
 Maximum recommended cable length from UD30 to sensor/STB termination box is 2000 feet.

Figure 9 – UD30 with GT3000 Power Supply Voltage

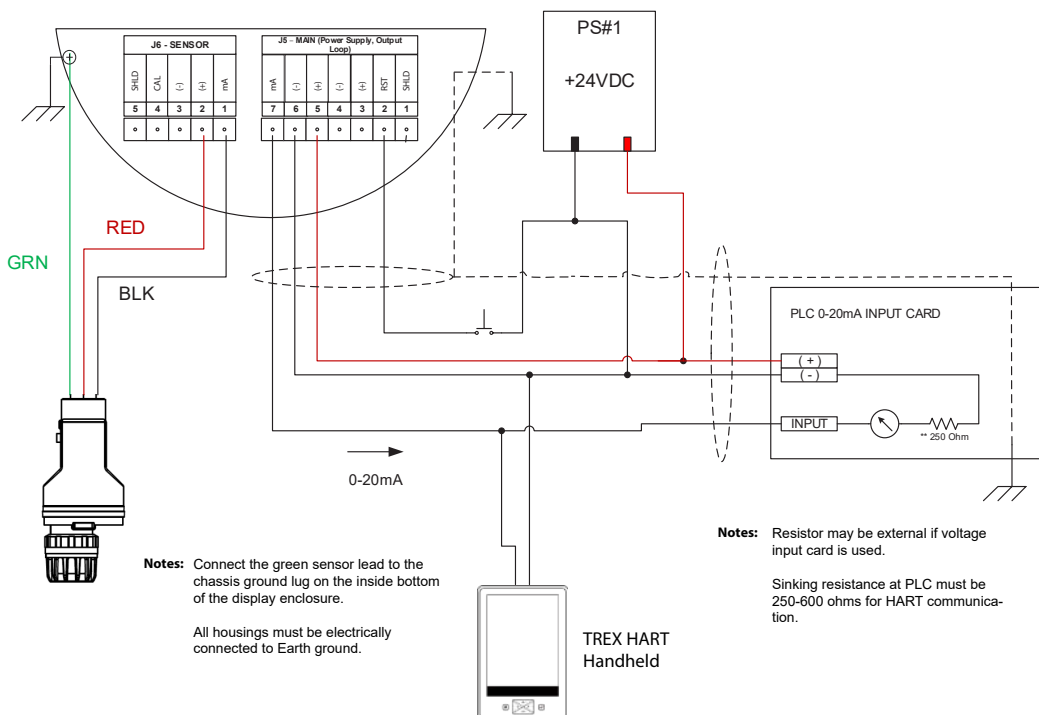

Figure 10 – GT3000 Detector Wired Directly to UD30 (GT3000 Sourcing)

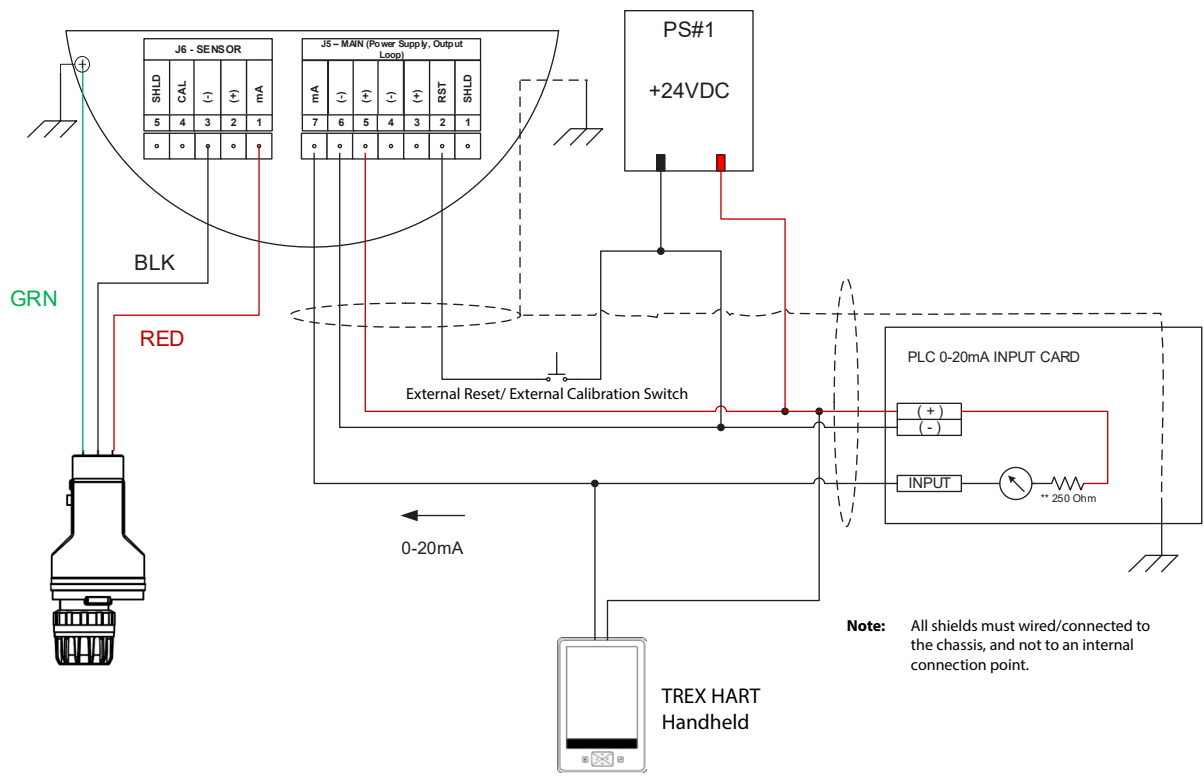

Figure 11 – GT3000 Detector Wired Directly to UD30 (GT3000 Sinking)

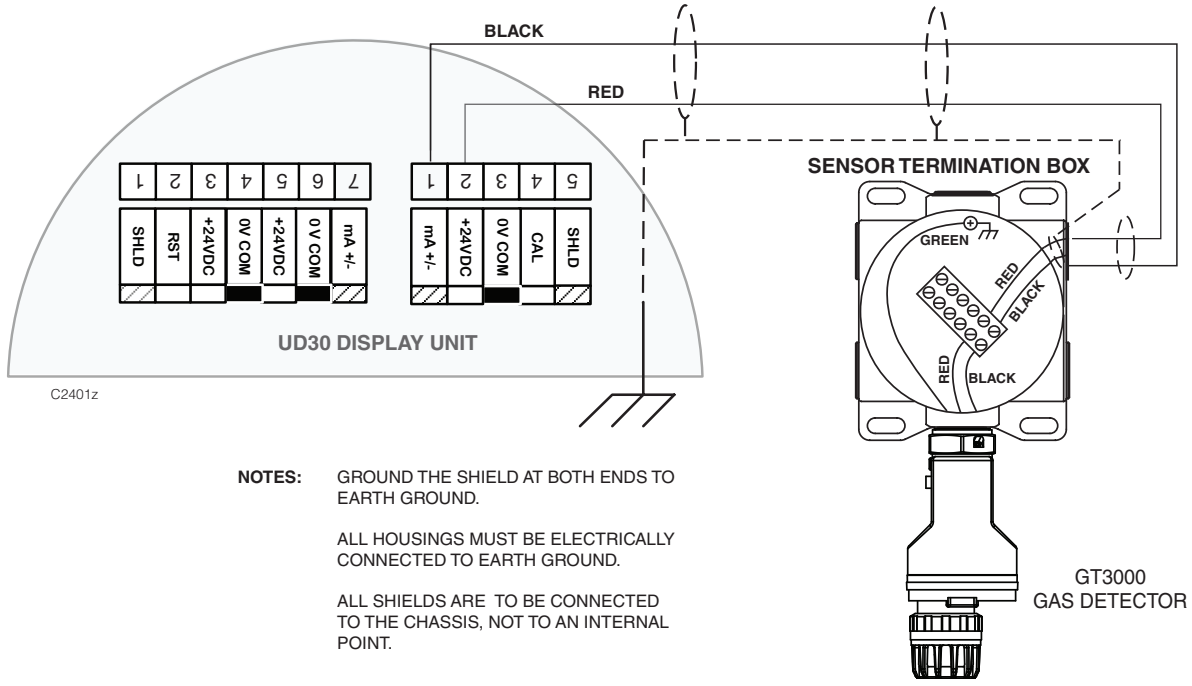

Figure 12 – UD30 Wired to GT3000 Detector with Sensor Termination Box



## ORIENTATION

The device must be mounted in a vertical position only, with the GT3000 pointing down.



Figure 13 – UD30 and GT3000 Orientation

## DETECTOR SELECTION

Select the detector type via the UD30 menu:  
MAIN MENU > SETUP > SETUP WIZARD > GT3000

## SENSOR SELECTION

Select the correct GTS sensor via the UD30 menu:  
MAIN MENU > SETUP > GAS TYPE > GAS

## LIVE MAINTENANCE

### NOTE

*The sensor module on the GT3000 Gas Detector can be hot swapped, i.e., replaced without removing power or de-classifying the area. To replace a GTX Transmitter connected to the UD30 with a new transmitter or a different detector type, the area **must** be de-classified.*

### NOTE

*If GTS sensor type is changed, select the correct gas type via the UD30 menu.*

### NOTE

*Removing the sensor module with power applied will result in a fault condition until a new sensor module of the same type is installed. When replacing an oxygen sensor, this action will also result in an alarm condition as the decreasing 4-20 mA signal passes through the alarm range. Inhibit response devices to prevent unwanted actuation.*

For complete information regarding sensor replacement with the GT3000 Gas Detector, refer to the GT3000 instruction manual, number 95-8616.

## CALIBRATION

### GT3000 WITH TOXIC GAS SENSOR

### NOTE

*Calibration of the GT3000 cannot be initiated from the UD30. Calibration must be initiated by applying the magnet to the switch on the GT3000.*

### From GT3000:

1. Using the magnet, activate the magnetic calibration switch on the GT3000. The green LED turns to yellow.

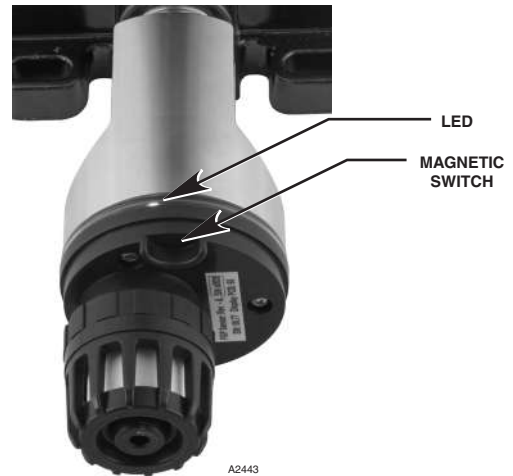

Figure 14 – Location of Magnetic Switch on GT3000

2. The UD30 will display “Waiting for Zero” on the main display screen, with the yellow LED on the detector housing illuminated continuously.
3. The UD30 will then display “Waiting for Signal” on the screen, while the yellow LED on the detector is flashing. The device automatically performs the zero calibration.
4. The UD30 will display “Waiting for Gas” on the screen, while the yellow LED on the detector is flashing.
5. Apply calibration gas to the sensor.
6. The UD30 will display “Waiting for Span” on the screen, while the yellow LED on the detector is flashing.
7. When the UD30 displays “Remove Cal Gas” on the screen and all LEDs on the detector housing are off, remove the calibration gas.

8. After successful calibration, the UD30 automatically returns to the normal display with the green LED illuminated on the detector.

## **GT3000 WITH OXYGEN SENSOR**

### *NOTE*

*Calibration of the GT3000 cannot be initiated from the UD30. Calibration must be initiated by applying the magnet to the switch on the GT3000.*

### **From GT3000:**

1. To log a calibration event select MAIN MENU > CALIBRATION > START CAL.

This must be done before the initiation of calibration at the GT3000.

Using the magnet, activate the magnetic calibration switch on the GT3000. The green LED turns to yellow.

2. The device automatically performs the zero calibration.  
The yellow LED on the GT3000 is on continuously.
3. When the yellow LED on the GT3000 flashes, the device automatically performs the span calculation.  
If using bottled 20.9% oxygen, apply immediately.
4. After successful calibration, the green LED on the GT3000 is on continuously. Remove calibration gas (if used).

# APPENDIX I

## UD30 with PIR9400 POINTWATCH IR GAS DETECTOR

### NOTE

For complete information regarding the PIR9400 Gas Detector, refer to instruction manual 95-8440.

## WIRING

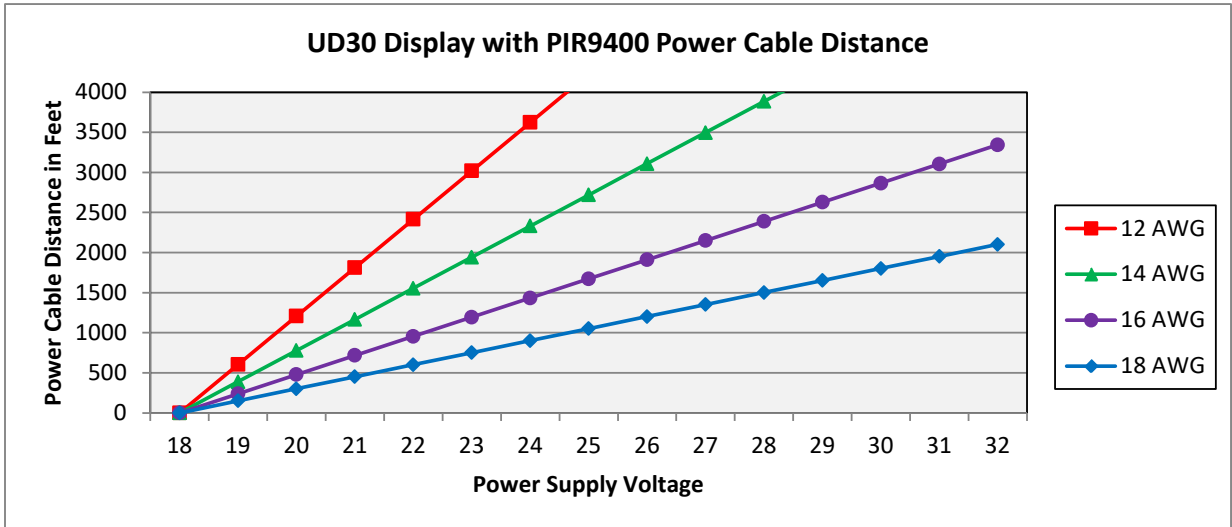

Notes: Maximum recommended cable length from power source to UD30 is 2000 feet.  
Maximum recommended cable length from UD30 to PIR9400/PIRTB termination box is 2000 feet.

Figure 15 – UD30 with PIR9400 Power Supply Voltage

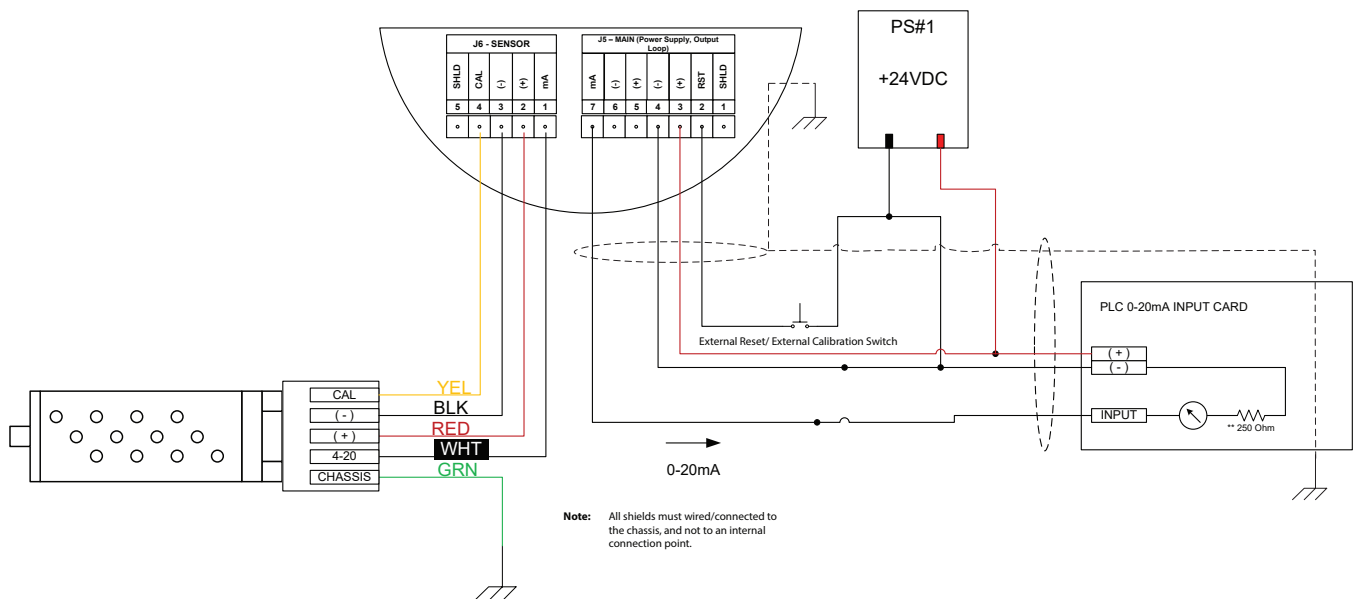

Figure 16 – PIR9400 Wired Directly to UD30

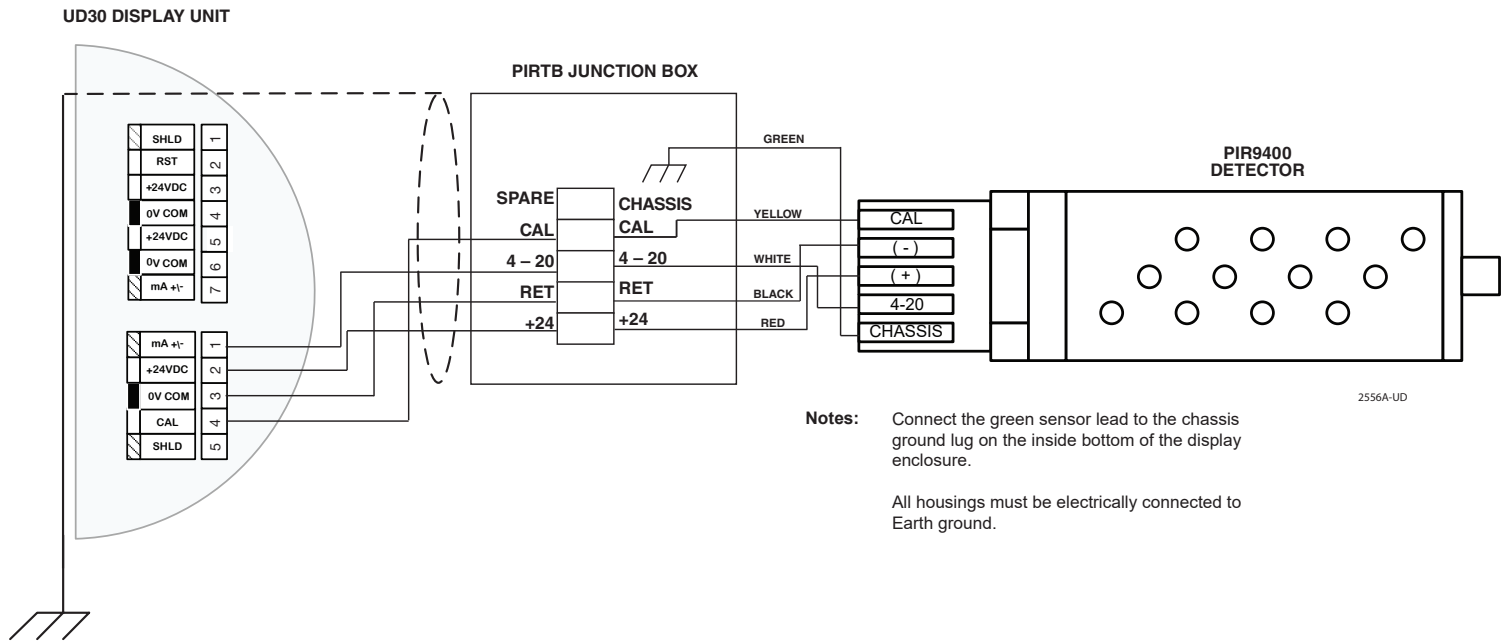

Figure 17 – UD30 Wired to PIR9400 with PIRTB Termination Box

## INSTALLATION NOTES

### IMPORTANT

Hydrocarbon-based grease emits hydrocarbon vapors that will be measured by PointWatch, resulting in inaccurate gas level readings. **Use only low vapor pressure Lubriplate grease or Teflon paste on the PointWatch detector and associated termination box.** Do not get grease on the optics of the detector. A suitable grease is listed in the “Ordering Information” section of this manual.

### IMPORTANT

In applications where both PointWatch and catalytic type sensors are used, ensure that the grease used to lubricate the PointWatch detector threads does not come into contact with the catalytic sensors, since poisoning of the catalytic sensors could result. It is strongly recommended that maintenance personnel wash their hands between handling the two types of sensors.

## ORIENTATION

It is highly recommended that the PIR9400 be installed in the horizontal position. The detector is not position-sensitive in terms of its ability to detect gas. However, the weather baffle assembly provides superior performance when installed in a horizontal position. See illustration below.



Figure 18 – UD30 and PIR9400 Orientation

## DETECTOR SELECTION

Select the detector via the UD30 menu:  
MAIN MENU > SETUP > SETUP WIZARD > PIR9400

The UD30 used with PIR9400 will default to a dead-cal configuration. For more information on calibration please refer to calibration section of the PIR9400 instruction manual (95-8440).

## CALIBRATION

To initiate calibration of the PIR9400 from the UD30 Display:

1. Using the magnet to activate the switches on the UD30 display, navigate to the "Calibration" menu.

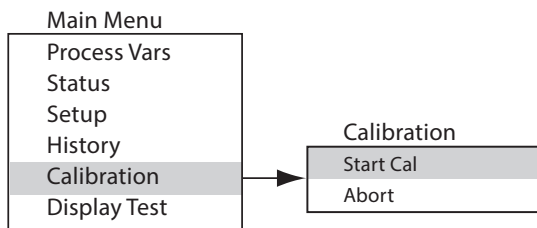

2. Activate "Start Cal" (Enter/Select) to start calibration.
3. The UD30 will display "Waiting for Zero" on the main display screen.
4. The UD30 will then display "Waiting for Gas" on the screen.
5. Apply calibration gas to the PIR9400.
6. The UD30 will continue to display "Waiting for Gas" on the screen.
7. When the UD30 displays "Remove Cal Gas" on the screen, remove the calibration gas from the PIR9400.
8. The UD30 automatically returns to the normal mode after successful calibration.

To initiate calibration from the PIRTB Termination Box while monitoring calibration using the UD30 display:

1. Using the magnet, activate the magnetic calibration switch on the PIRTB Termination Box. The LED at the PIRTB turns from off to steady red.
2. The UD30 will display "Waiting for Zero" on the main display screen, with a steady red LED at the PIRTB.

3. The UD30 will then display "Waiting for Gas" on the screen, while the LED at the PIRTB is flashing red.
4. Apply calibration gas to the PIR9400 detector.
5. The UD30 will display "Waiting for Span" on the screen, with a red flashing LED at the PIRTB.
6. When the UD30 displays "Remove Cal Gas" on the screen and the LED at the PIRTB turns off, remove the calibration gas.
7. After successful calibration, the UD30 automatically returns to the normal mode, and the LED on the PIRTB remains off.

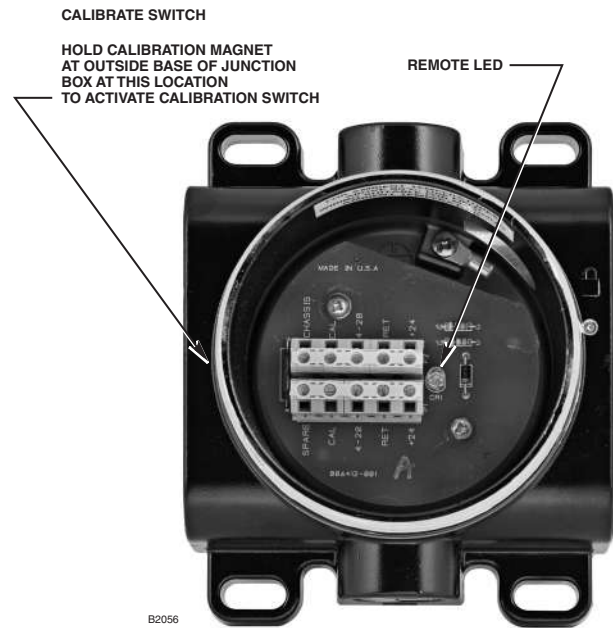

Figure 19 – PIRTB Termination Box

# APPENDIX J

## UD30 with MODEL PIRECL

### NOTE

For complete information regarding the PIRECL Gas Detector, refer to instruction manual 95-8526.

## WIRING

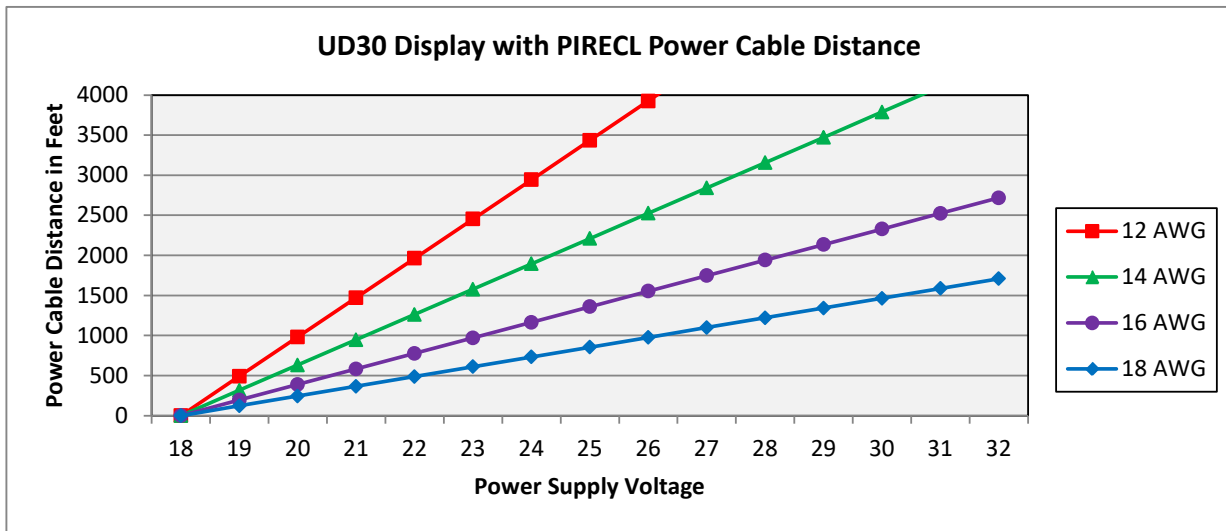

Notes: Maximum recommended cable length from power source to UD30 is 2000 feet.  
 Maximum recommended cable length from UD30 to detector/STB termination box is 2000 feet.

Figure 20 – UD30 with PIRECL Power Supply Voltage

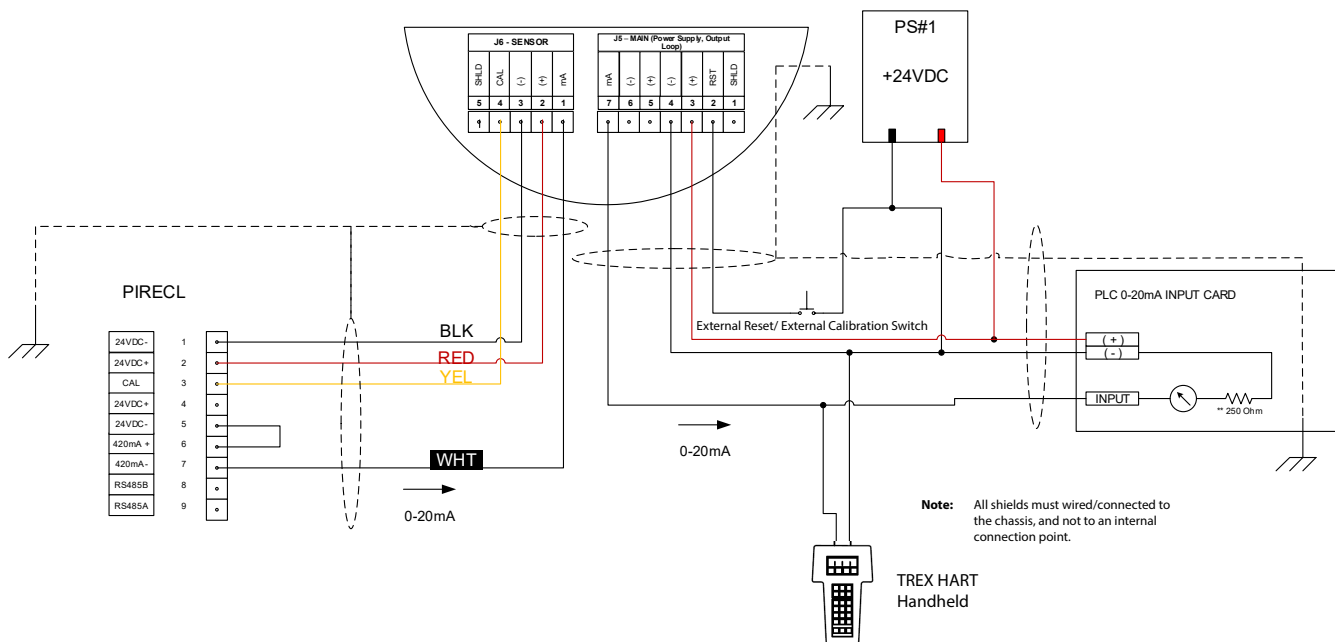

Figure 21 – Model PIRECL Wired Directly to UD30

## ORIENTATION

It is highly recommended that the PIRECL be installed in the horizontal position. The detector is not position-sensitive in terms of its ability to detect gas. However, the weather baffle assembly provides superior performance when the PIRECL is installed with the baffle in a horizontal position.

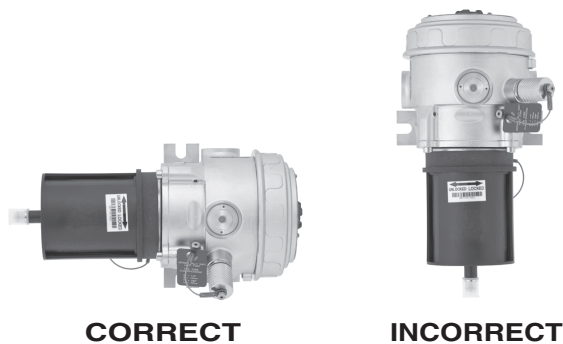

Figure 22 – PIRECL Orientation

## DETECTOR SELECTION

Select detector via the UD30 menu:

MAIN MENU > SETUP > SETUP WIZARD > PIRECL

## CALIBRATION

### NOTE

It's highly recommended to configure the PIRECL for the PIR9400 fault mode so the UD30 can correctly decode all the fault levels and properly indicate the calibration steps. If the PIRECL is used with the UD30 in User Defined mode or Eclipse fault mode it will not give the correct prompts and could cause confusion. PIRECL detectors are shipped from the factory in Eclipse Fault Mode which is compatible with the UD30. If the PIRECL Fault Mode is changed to PIR9400 Fault Mode or User Defined Fault Mode, User Defined or in the Eclipse mode, the UD30 will display a fault during zero and span calibration. The Eclipse will still successfully calibrate if the LED prompts are followed. However, the UD30 Calibration Log will always show a CAL FAILED event when calibrated in either of these two modes.

### NOTE

The UD30 used with PIRECL will default to a dead-cal configuration. For information on live-calibration, please refer to Appendix F, section F.2.3.11.

To initiate calibration of the PIRECL from the UD30 Display:

- Using the magnet to activate the switches on the UD30 display, navigate to the "Calibration" menu.

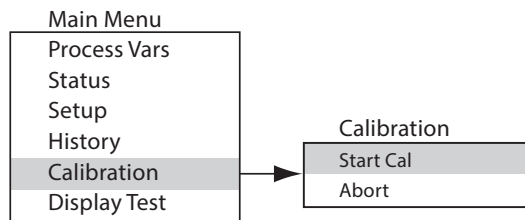

- Activate "Start Cal" (Enter/Select) to start calibration.
- The UD30 will display "Waiting for Zero" on the main display screen, with a solid red LED on the PIRECL housing illuminated.
- The UD30 will then display "Waiting for Gas" on the screen, while the LED on the PIRECL is flashing red.
- Apply calibration gas to the PIRECL
- The UD30 will display "Waiting for Span" on the screen, while a red flashing LED on the PIRECL housing is illuminated.
- When the UD30 displays "Remove Cal Gas" on the screen and the LED on the PIRECL housing is off, remove the calibration gas.
- After successful calibration, the UD30 automatically returns to the normal display with the green LED illuminated on the PIRECL housing.

To initiate calibration from the PIRECL while monitoring calibration using the UD30 display:

- Using the magnet, activate the magnetic calibration switch on the PIRECL detector. See Figure below.

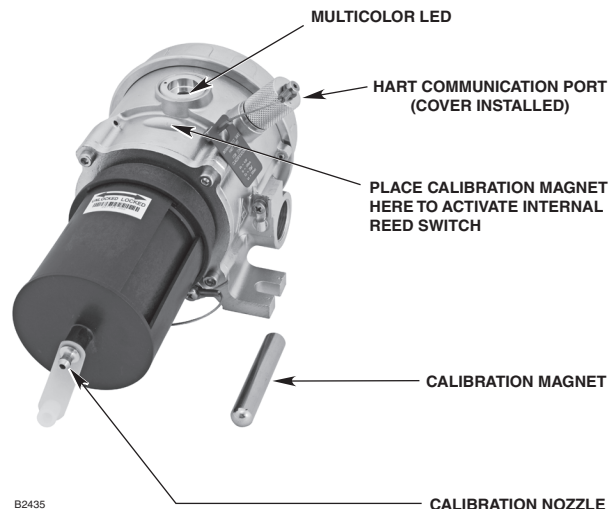

Figure 23 – Model PIRECL Gas Detector

The LED turns from green to red.

2. The UD30 will display "Waiting for Zero" on the main display screen, with a solid red LED on the PIRECL housing illuminated.
3. The UD30 will then display "Waiting for Gas" on the screen, while the LED on the PIRECL is flashing red.
4. Apply calibration gas to the PIRECL detector.
5. The UD30 will display "Waiting for Span" on the screen, while a red flashing LED on the PIRECL housing is illuminated.
6. When the UD30 displays "Remove Cal Gas" on the screen and the LED on the PIRECL housing is off, remove the calibration gas.
7. After successful calibration, the UD30 automatically returns to the normal mode with the green LED illuminated on the PIRECL.



## APPENDIX K

### UD30 with GENERIC 4-20 mA SENSORS

#### NOTE

*For complete information regarding installation, wiring, and calibration of the sensor, refer to the instruction manual provided by the sensor manufacturer.*

#### OPERATION

The UD30 can be used with generic sensors that generate a calibrated linear 4-20 mA signal, with or without HART. The UD30 allows the operator to select the upper and lower range values and unit of measurement. The UD30 then analyzes the 4-20 mA input signal from the sensor and displays the value with the designated measurement unit, and also controls the alarm outputs.

#### NOTE

*The SETUP WIZARD must be used to change parameters such as units, gas type, and fault levels.*

#### UPPER AND LOWER RANGE VALUES

The upper range value (URV) and lower range value (LRV) are selected using the magnetic tool and the UD30's menu system (SETUP> SETUP WIZARD > Generic Device). The URV corresponds to the 20 mA signal while the LRV corresponds to 4 mA. The default values are 0 for the LRV and 100 for the URV.

#### MEASUREMENT UNIT TEXT

The operator can select the appropriate measurement unit from a pre-entered list: % (default), %LFL, LFLM, MA, or they can enter their own custom 4-character string. Measurement unit text is displayed on the main screen with the process variable.

#### LOW FAULT THRESHOLD

The operator can enter a low input fault threshold in the range of 0.5–4 mA (default is 3.5 mA). When the input signal is at or below this point, an "Out of Range Low Fault" is annunciated. This feature can be enabled/disabled as desired.

#### HIGH FAULT THRESHOLD

The operator can enter a high input fault threshold in the range of 20–27 mA (default is 21 mA). When the input signal is at or above this point, an "Out of Range High Fault" is annunciated. This feature can be enabled/disabled as desired.

#### ALARMS

The Low and High alarm levels are independently field

adjustable. Alarm levels are set and displayed with the selected measurement units. All alarm levels must be within the LRV to URV range.

#### ALARM LATCHING

Latching or non-latching function is independently selectable for each alarm. The default setting is non-latching. Latched alarms can be reset with a "Reset Latched Alarms" command from the menu system or a power cycle.

#### DETECTOR SELECTION

Select detector via UD30 menu:  
MAIN MENU > SETUP> SETUP WIZARD > Generic Device

#### SENSOR CALIBRATION

The UD30 does not support generic sensor calibration. Generic sensors must be pre-calibrated following the procedure described in the instruction manual provided by the sensor manufacturer.

#### 4-20 MA OUTPUT READING

While in Generic mode, the UD30 displays values below the 4 mA level to allow the use of 0-20 mA sensors.

## APPENDIX L

### UD30 with FLEXSONIC ACOUSTIC GAS DETECTOR

#### NOTE

For complete information regarding the FlexSonic Acoustic Detector, refer to instruction manual 95-8657.

## WIRING

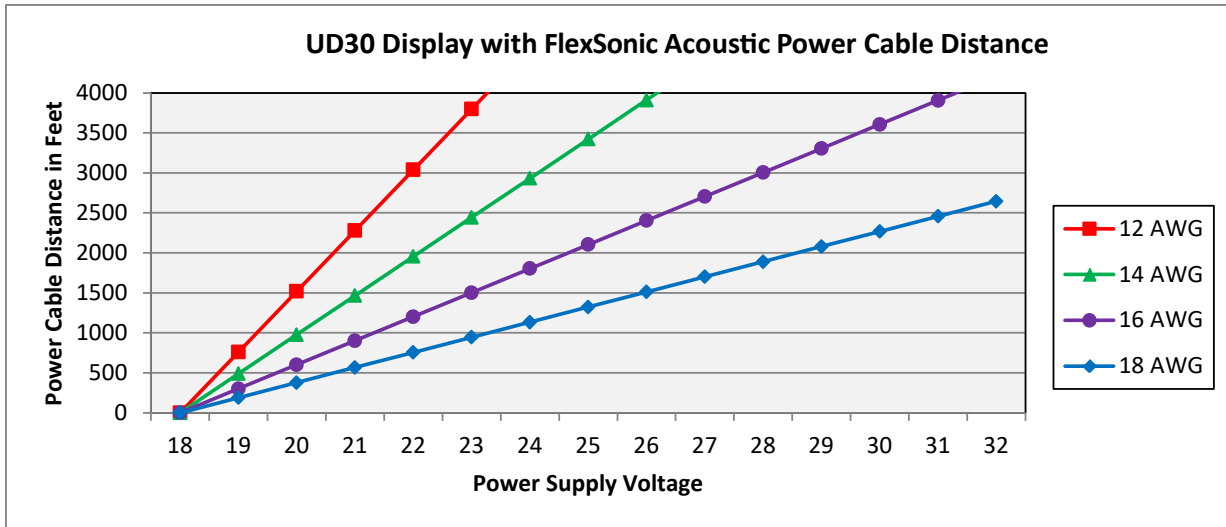

Notes: Maximum recommended cable length from power source to UD30 is 2000 feet.  
Maximum recommended cable length from UD30 to sensor is 2000 feet.

Figure 24 – UD30 with FlexSonic Acoustic Power Supply Voltage

## INSTALLATION

#### NOTE

Detector housings must be electrically connected to earth ground. A dedicated earth ground terminal is provided.

#### NOTE

The AC100 has an Intrinsic Safety (IS) Barrier. Proper NEC/CEC IS grounded must be ensured.

#### NOTE

The detector must always be installed per local installation codes.

#### NOTE

Use of a threaded adapter for connecting the AC100 to the STB or ATX10 is prohibited.

#### NOTE

The ATX10 transmitter module is shipped with the SD card installed in the memory module. A piece of tape has been installed to secure the card in place and prevent it from becoming dislodged during shipping. The shipping tape should be removed prior to commissioning the acoustic detector.

## DETECTOR SELECTION

Select detector via UD30 menu:  
MAIN MENU > SETUP > SETUP WIZARD > ATX10

## UD30 OPERATION

The UD30 will display the 4-20 mA output from the acoustic device.

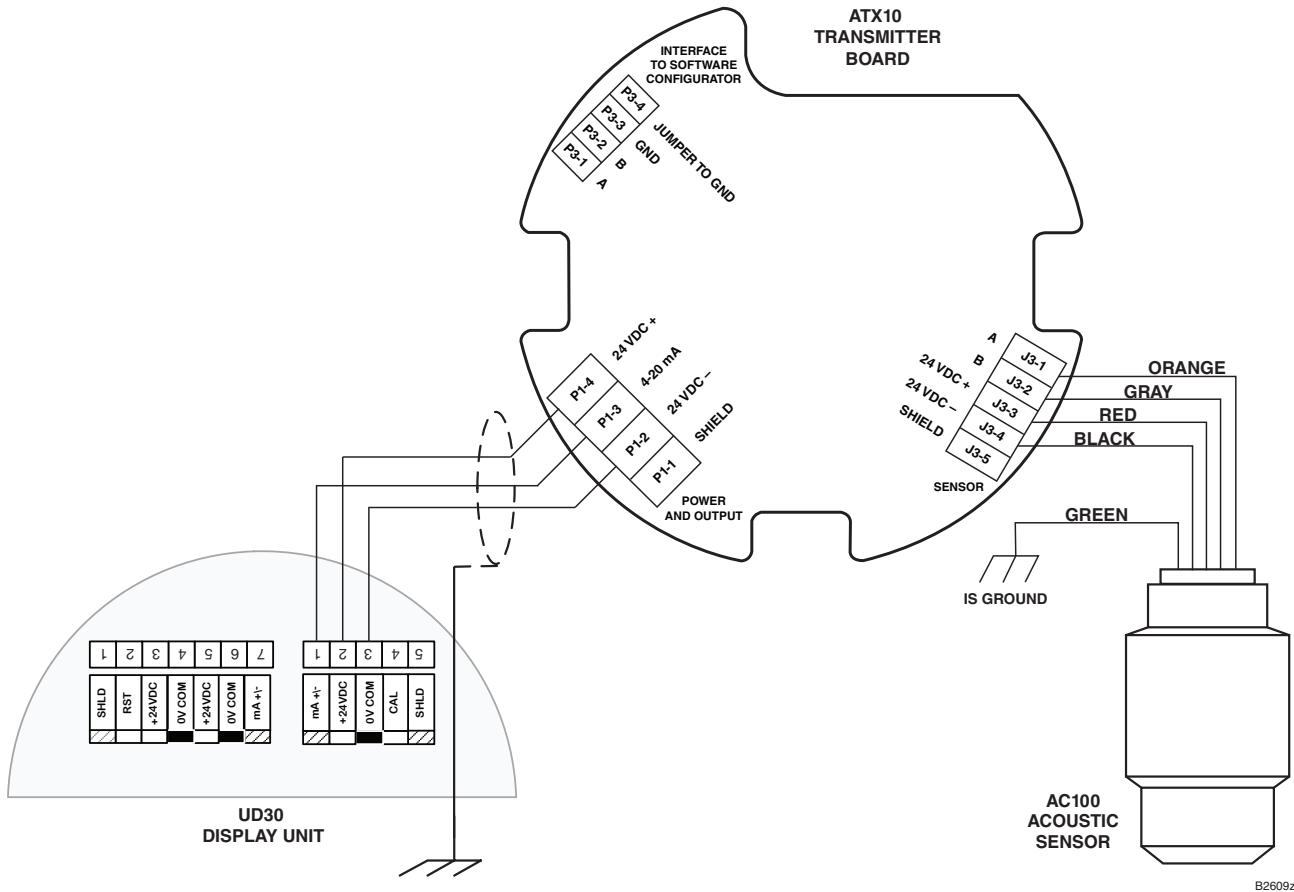

B2609z

**NOTES:** DEVICE HOUSINGS MUST BE ELECTRICALLY CONNECTED TO EARTH GROUND.

CONNECT THE GREEN WIRE FROM THE AC100 TO THE GROUND SCREW INSIDE THE ATX10 HOUSING.

SHIELDED TWISTED PAIR IS RECOMMENDED FOR SIGNAL WIRING, 500 FEET MAXIMUM.

ALL SHIELDS MUST BE WIRED/CONNECTED TO THE CHASSIS, AND NOT TO AN INTERNAL CONNECTION POINT.

Figure 25 – ATX10 Transmitter with AC100 Wired Directly to UD30

# APPENDIX M

## UD30 with MODEL PIRDUCT

### NOTE

For complete information regarding the PIRDUCT Gas Detector, refer to instruction manual 95-8573.

## WIRING

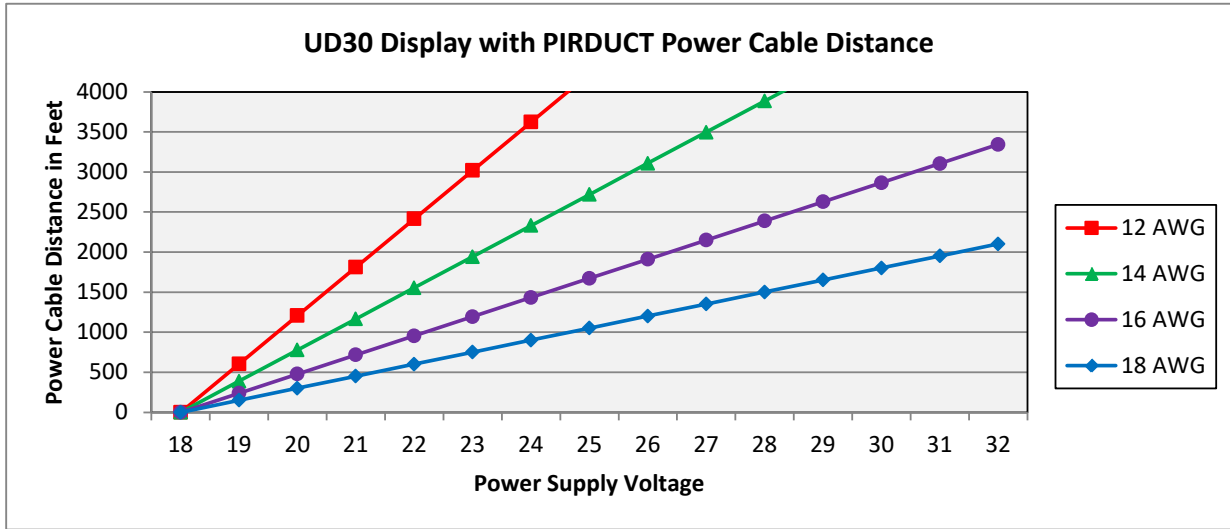

Notes: Maximum recommended cable length from power source to UD30 is 2000 feet.  
Maximum recommended cable length from UD30 to PIRDUCT/PIRTB termination box is 2000 feet.

Figure 26 – UD30 with PIRDUCT Power Supply Voltage

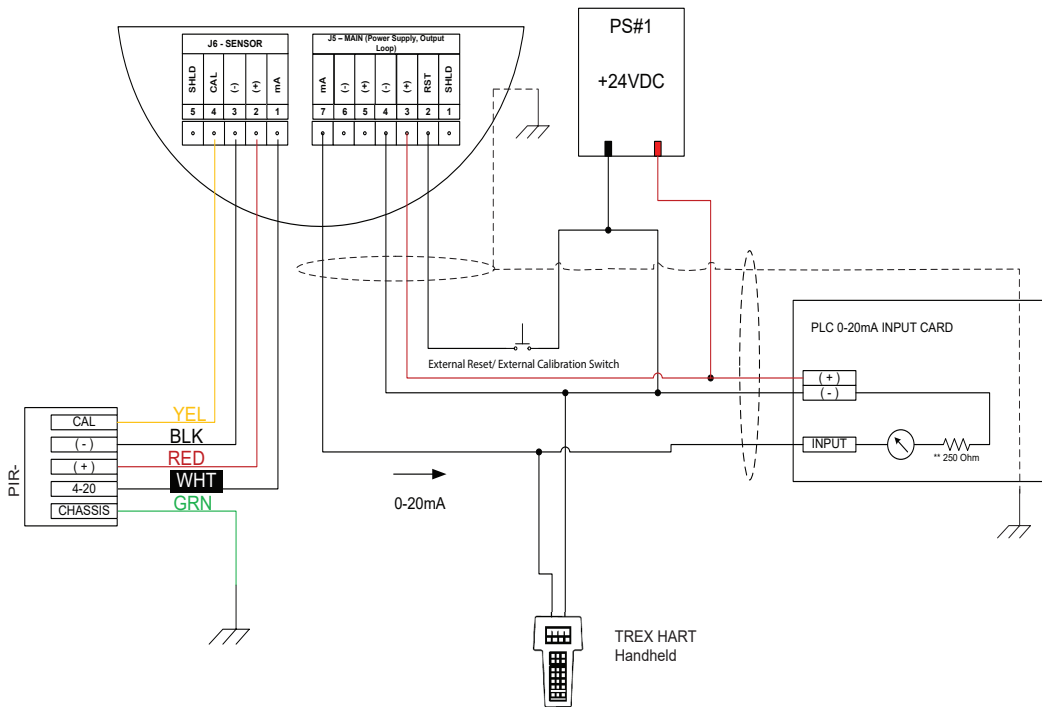

Figure 27 – PIRDUCT Wired Directly to UD30

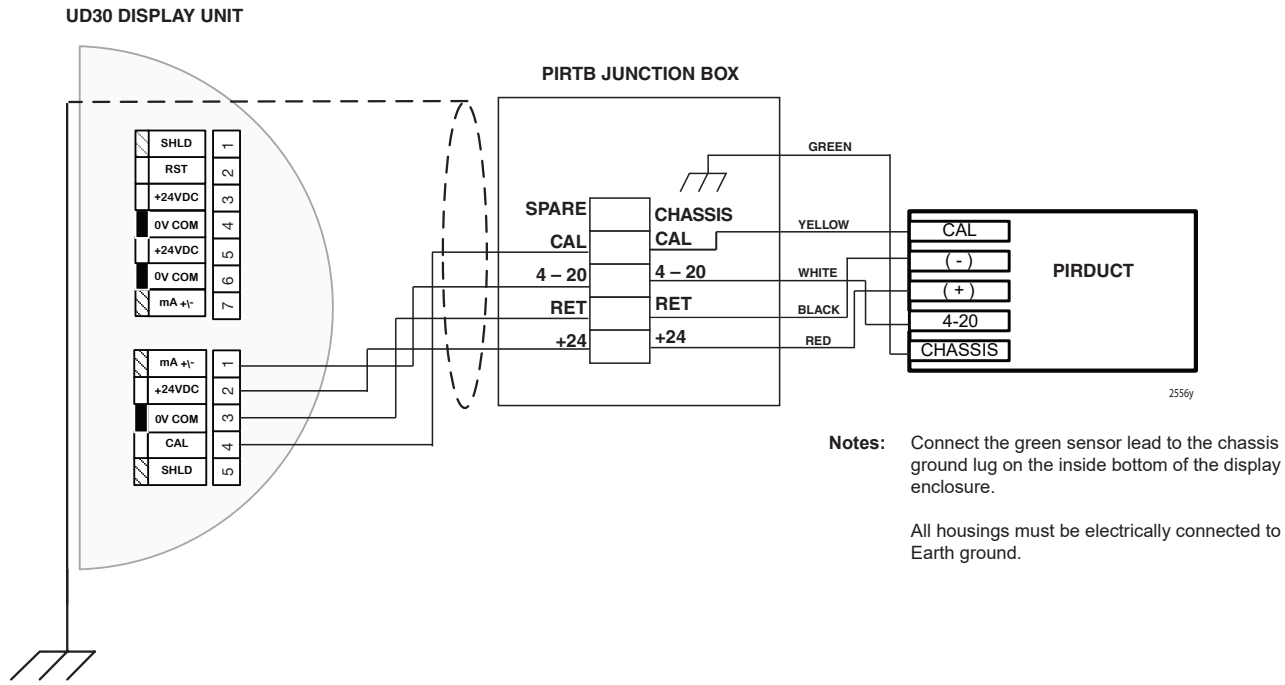

Figure 28 – UD30 Wired to PIRDUCT with PIRTB Termination Box

## INSTALLATION NOTES

### IMPORTANT

Hydrocarbon-based grease emits hydrocarbon vapors that will be measured by PIRDUCT, resulting in inaccurate gas level readings. **Use only low vapor pressure Lubriplate grease or Teflon paste on the PIRDUCT detector and associated termination box.** Do not get grease on the optics of the detector. A suitable grease is listed in the “Ordering Information” section in this manual.

### IMPORTANT

In applications where both PIRDUCT and catalytic type sensors are used, ensure that the grease used to lubricate the PIRDUCT detector threads does not come into contact with the catalytic sensors, since poisoning of the catalytic sensors could result. It is strongly recommended that maintenance personnel wash their hands between handling the two types of sensors.

## ORIENTATION

The PIRDUCT Detector is a position sensitive instrument. It must be installed in the proper orientation to achieve proper vapor detection. Ensure that the installation location selected will accommodate the instrument in the proper mounting orientation.

## CORRECT

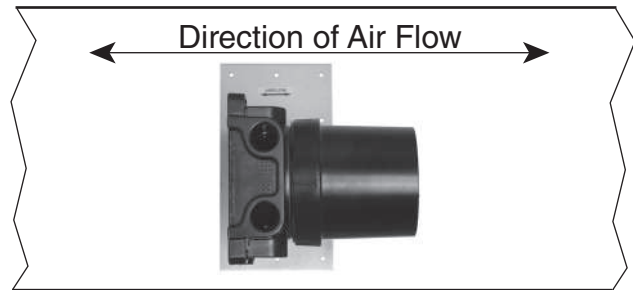

**IMPORTANT:** MOUNTING PLATE **MUST** BE ORIENTED AS SHOWN. ONCE THE MOUNTING PLATE IS SECURED TO THE DUCT WALL, THE TERMINATION BOX CAN BE ROTATED TO ANY CONVENIENT POSITION.

## INCORRECT



Figure 29 – Orientation of PIRDUCT Mounting Plate Relative to Direction of Airflow through Duct

## DETECTOR SELECTION

Select detector via the UD30 menu:

MAIN MENU > SETUP > SETUP WIZARD > PIRDUCT

## CALIBRATION

To initiate calibration of the PIRDUCT from the UD30 Display:

1. Using the magnet to activate the switches on the UD30 display, navigate to the "Calibration" menu.

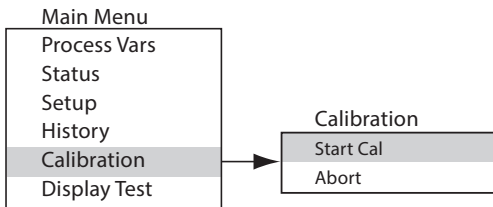

2. Activate "Start Cal" (Enter/Select) to start calibration.
3. The UD30 will display "Waiting for Zero" on the main display screen.
4. The UD30 will then display "Waiting for Gas" on the screen.
5. Apply calibration gas to the PIRDUCT.
6. The UD30 will continue to display "Waiting for Gas" on the screen.
7. When the UD30 displays "Remove Cal Gas" on the screen, remove the calibration gas from the PIRDUCT.
8. The UD30 automatically returns to the normal mode after successful calibration.

To initiate calibration from the PIRTB Termination Box while monitoring calibration using the UD30 display:

1. Using the magnet, activate the magnetic calibration switch on the PIRTB Termination Box. The LED at the PIRTB turns from off to steady red.
2. The UD30 will display "Waiting for Zero" on the main display screen, with a steady red LED at the PIRTB.

3. The UD30 will then display "Waiting for Gas" on the screen, while the LED at the PIRTB is flashing red.
4. Apply calibration gas to the detector.
5. The UD30 will display "Waiting for Span" on the screen, with a red flashing LED at the PIRTB.
6. When the UD30 displays "Remove Cal Gas" on the screen and the LED at the PIRTB turns off, remove the calibration gas.
7. After successful calibration, the UD30 automatically returns to the normal mode, and the LED on the PIRTB remains off.

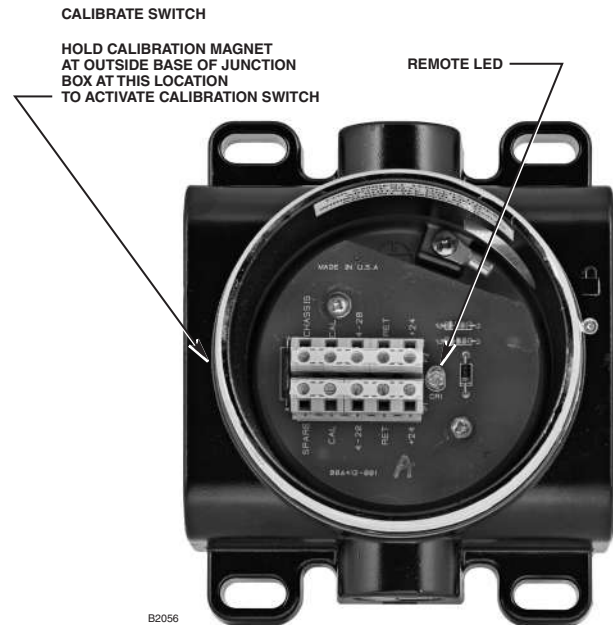

Figure 30 – PIRTB Termination Box

# APPENDIX N

## UD30 with LS2000 LINE OF SIGHT GAS DETECTOR

### NOTE

For complete information regarding the LS2000 Gas Detector, refer to instruction manual 95-8714.

## WIRING

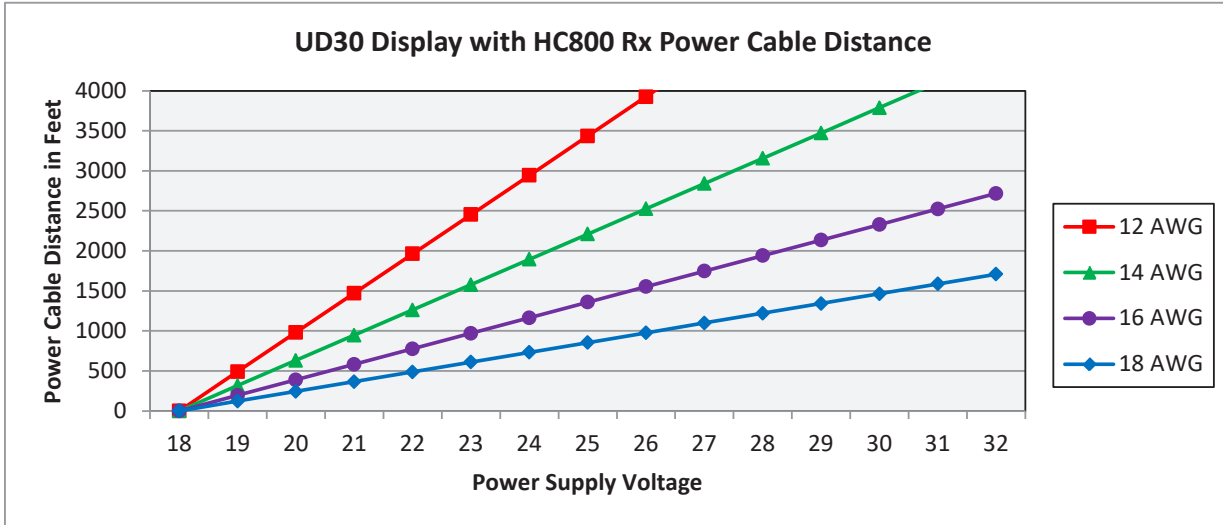

Notes: Maximum recommended cable length from power source to UD30 is 2000 feet.  
Maximum recommended cable length from UD30 to sensor is 2000 feet.

Figure 31 – UD30 with LS2000 Power Supply Voltage

### LS2000 RECEIVER WITHOUT RELAYS

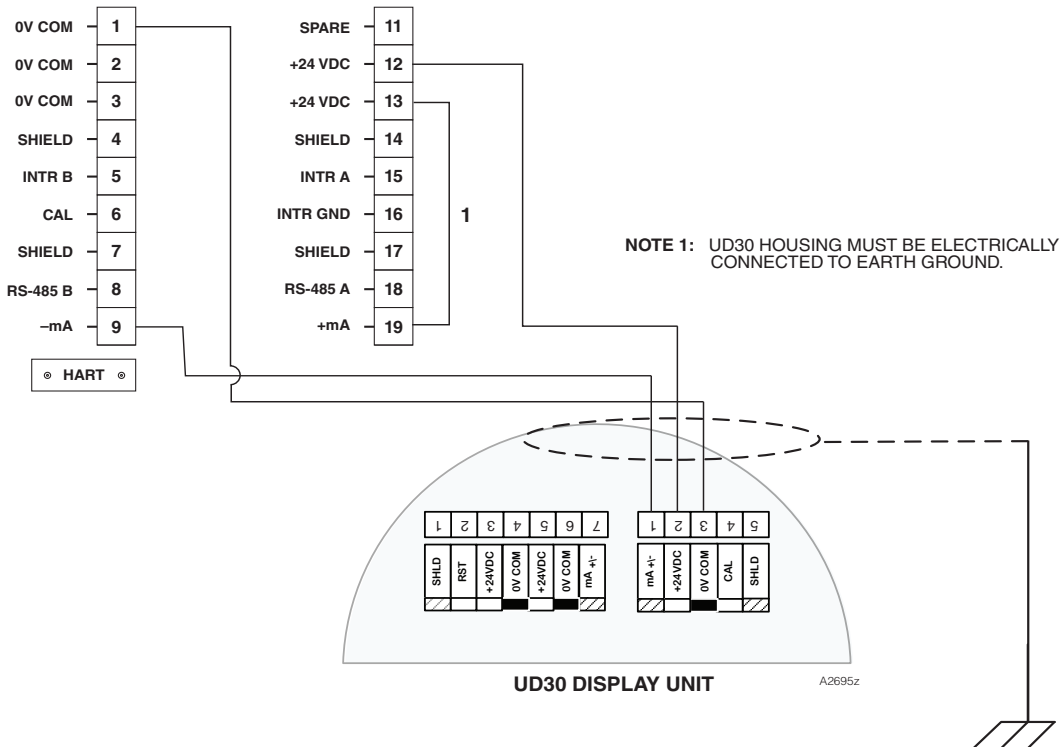

Figure 32 – LS2000 Wired Directly to UD30

## INSTALLATION

LS2000 modules must be affixed to a solid, non-vibrating structure capable of supporting a minimum of 100 lbs (46 kg), located within the system's rated separation distance. See examples below.

In all cases, consider whether additional bracing or support is needed to ensure the structural integrity of the module installation. Remember that accurate module alignment is essential for proper performance of a line-of-sight gas detection system. Movement may have a detrimental effect on alignment. This is especially true for installations with significant module separation distances.

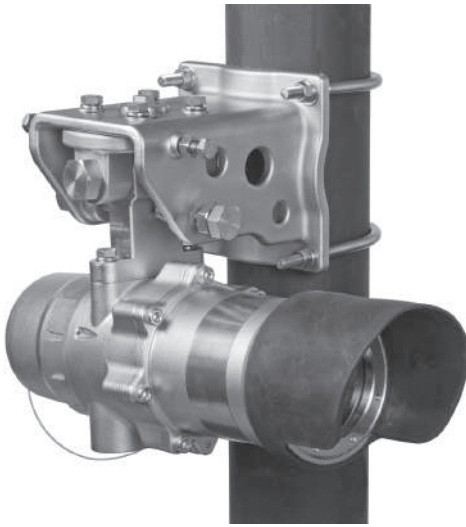

Figure 33 – LS2000 Gas Detector Mounted to Vertical Post

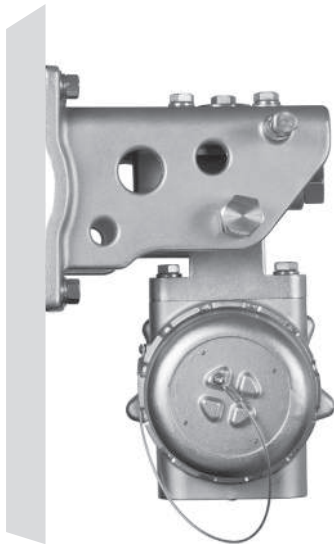

Figure 34 – LS2000 Gas Detector Mounted to Flat Surface (Refer to LS2000 Instruction Manual for mounting plate hole spacing dimensions.)

## DETECTOR SELECTION

Select detector via the UD30 menu:  
MAIN MENU > SETUP> SETUP WIZARD > LS2000

## CALIBRATION

To initiate zero calibration of the LS2000 from the UD30 Display:

- Using the magnet to activate the switches on the UD30 display, navigate to the “Calibration” menu.

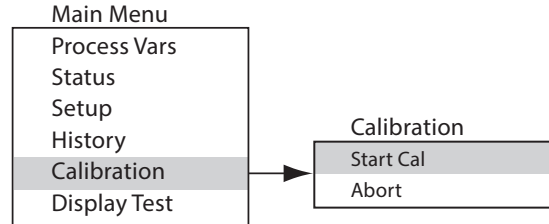

- Activate “Start Cal” (Enter/Select) to start calibration.
- The UD30 will display “Waiting for Zero” on the main display screen, with a solid red LED on the LS2000 housing illuminated.
- After the calibration is successfully completed, the UD30 automatically returns to the normal display with the green LED illuminated on the LS2000 housing.

UD30 mA Output During Calibration (UD30 with LS2000)	
UD30 Display Reading	UD30 Output
Waiting for Zero	1.0*
Back to Normal	4.0

\*Can be set at 2.2 mA or as configured by user.

To initiate zero calibration from the LS2000:

- Using the magnet, activate the magnetic calibration switch on the LS2000 receiver. See Figure below. The green LED will turn red.
- The UD30 will display “Waiting for Zero” on the main display screen, with a solid red LED on the LS2000 housing illuminated.



**NOTE**

*The UD30 will go into FAULT when calibration is initiated at the LS2000. This is because the LS2000 does not change the Cal Line when calibrating, so the UD30 has to assume the loop current below 2.1 mA indicates a FAULT.*

3. After the calibration is successfully completed, the UD30 automatically returns to the normal display with the green LED illuminated on the LS2000 housing.

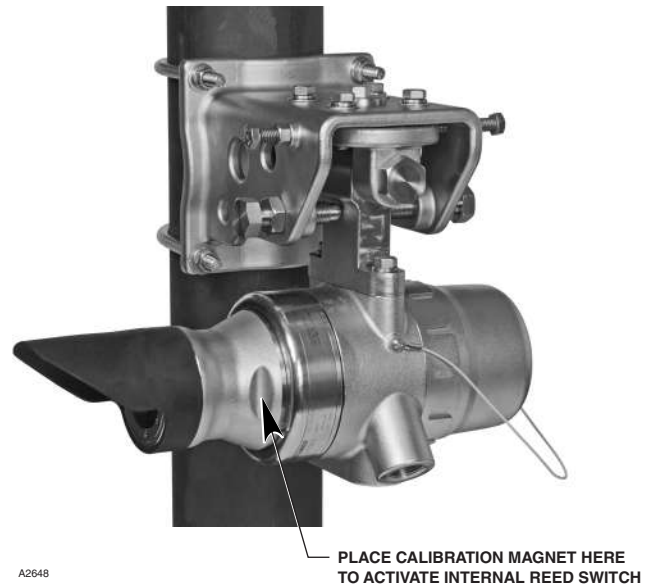

Figure 35 – Location of Receiver's Internal Magnetic Switch

# APPENDIX O

## UD30 with CGS GAS SENSOR

### NOTE

The CGS is not approved for stand-alone use. Only use according to the Approval data in this manual.

## WIRING

**UD30 w/CGS Board Power Cable Distance with Maximum Sensor Separation of 500 Feet Connected remotely to an STB (Sensor Termination Box)**

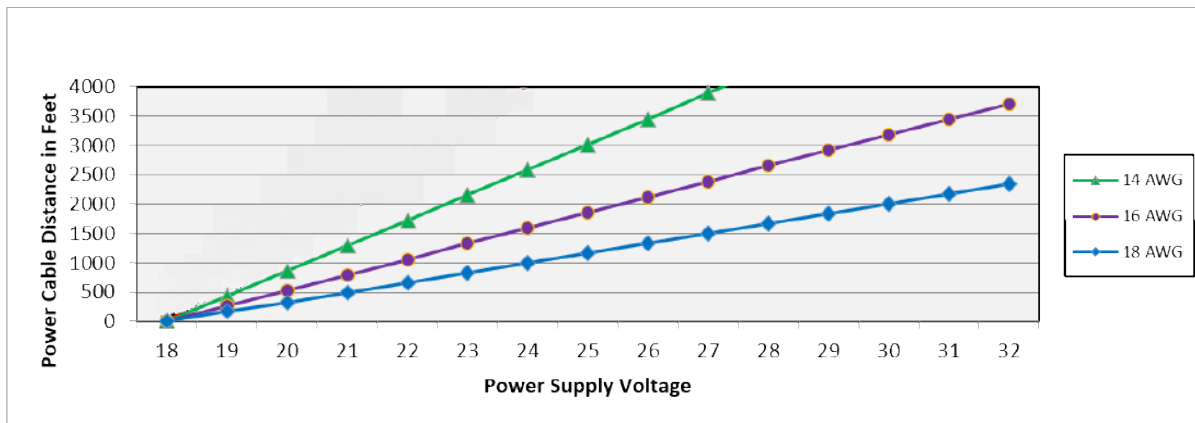

Recommended maximum cable from the power source to the UD30 is 2000 feet or 609.9 meters.  
 Recommended maximum cable length from the UD30 to the sensor is 500 feet or 152 meters for 16 AWG wire.

Figure 38 – UD30 with 18 Volt Power Supply Voltage

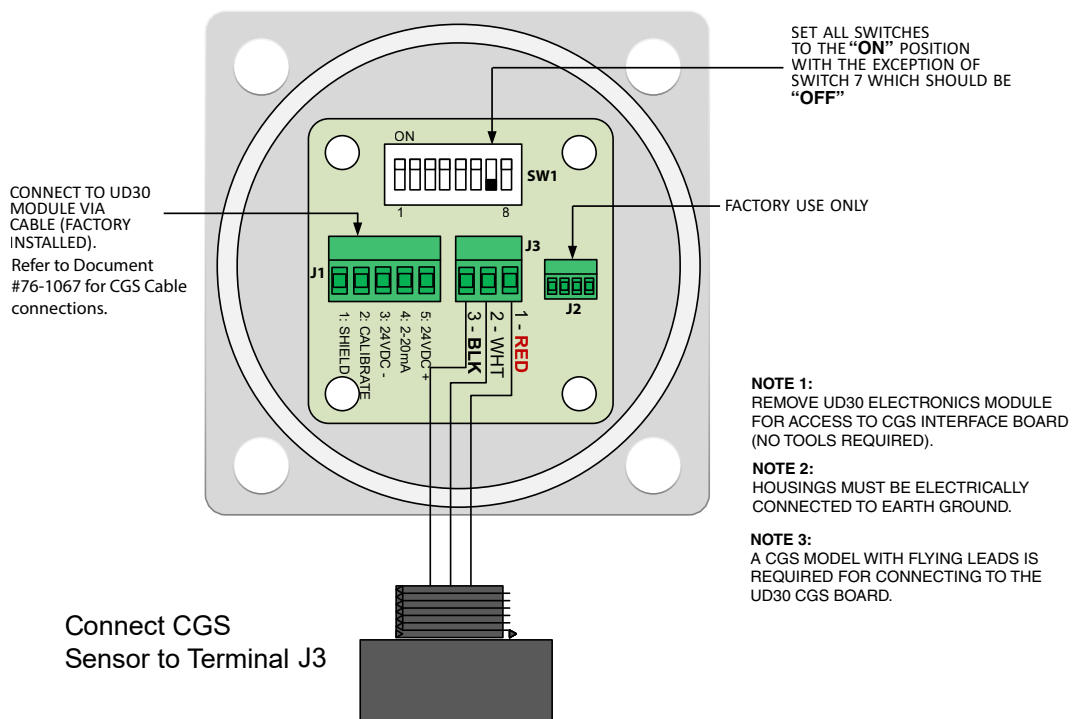

Figure 39 – CGS Wired Directly to the UD30

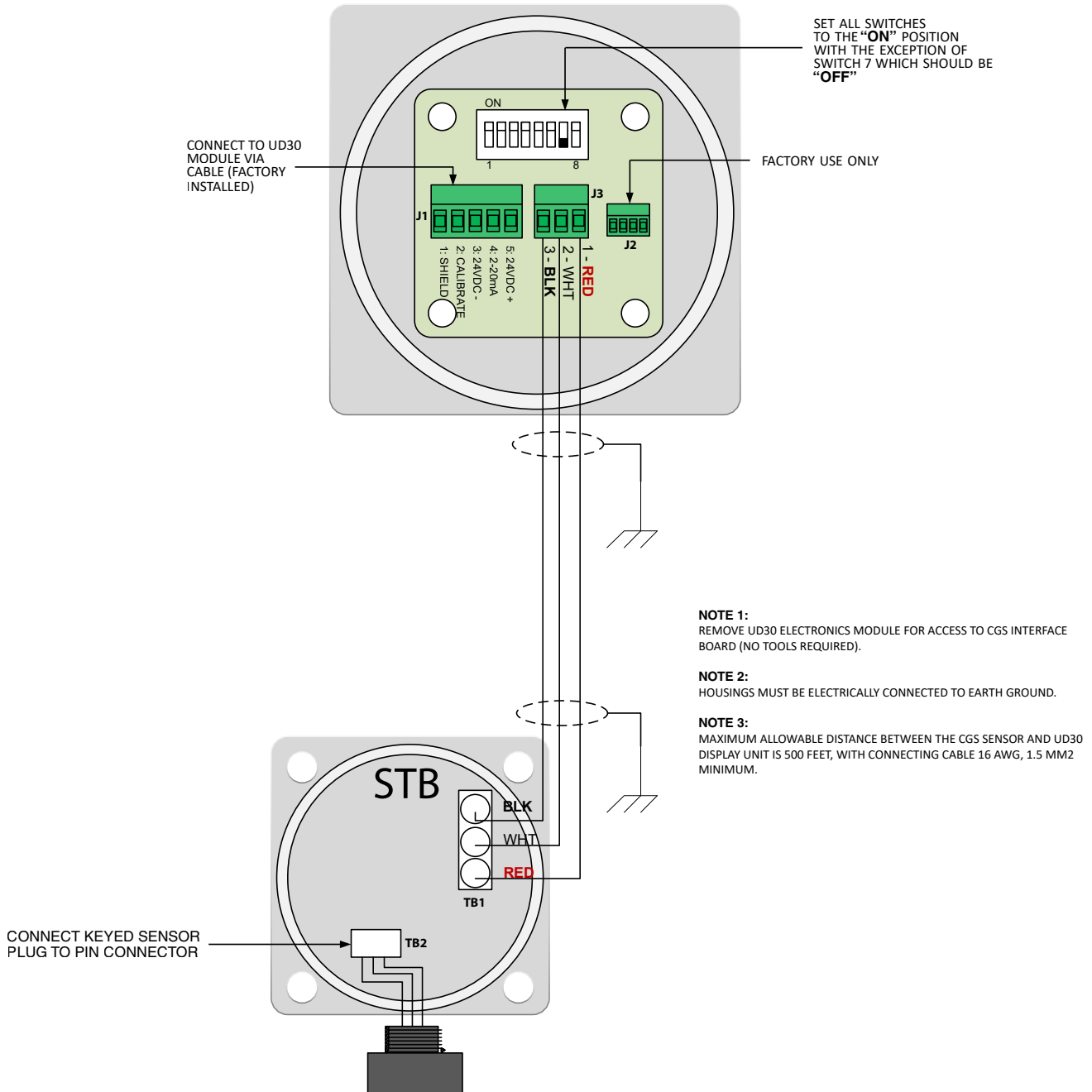

Figure 40 – CGS Wired Directly to the STB Sensor Termination Box

## INSTALLATION NOTES

### IMPORTANT

*Metric Sensors must provide five (5) threads of engagement. NPT Sensors must provide five (5) threads available.*

### NOTE

*The UD30 with the CGS Conditioning Board and the CGS sensor is certified as a "General Purpose Gas Detector" and performance approved to standards FM 6320, ATEX 60079-29-1, and IEC 60079-29-1. UD30 with CGS is certified for Methane and Propane gases, 0-100% LFL.*

### NOTE

*The UD30 with CGS must be mounted vertically with the sensor pointing down. Certification allows for a variance of +/- 15° either side of vertical.*

### NOTE

*Only Constant Current type CGS sensors may be used with the UD30.*

### CAUTION

*The sintered metal flame arrestor is an integral part of the combustible gas sensor. DO NOT operate the gas detector if the flame arrestor is damaged or missing, since the exposed element is a potential ignition source.*

### CAUTION

*Silicone-based lubricants must **never be used** on or near the CGS sensor since this can result in irreversible damage to the sensing element. See the following section for more information regarding factors that affect sensor sensitivity.*

### CAUTION

*When used as a stand-alone device, the high alarm must always be programmed for latching operation. When used in conjunction with a Control Unit and then configured for a non-latching high alarm, the Control Unit must always latch and require a deliberate manual action to clear a high gas alarm.*

## FACTORS AFFECTING SENSOR SENSITIVITY

There are a variety of factors that can cause a decrease in the sensitivity of catalytic type combustible gas sensors. The following information identifies the most common substances that can have a detrimental effect on the catalytic gas sensor. Under no circumstances should these lists be considered as all inclusive. Interfering or contaminating substances include materials that can clog the pores of the sintered

steel flame arrestor and reduce the gas diffusion rate to the sensor. Examples include:

1. Dirt or oil.

A dust cover or splash guard may be installed to protect the flame arrestor. The dust cover may be cleaned using an organic solvent and an ultrasonic bath unless the contaminant is insoluble. Replace dust cover if there is any doubt.

### NOTE

*The UD30/CGS configuration was not tested and certified with dust covers.*

2. Corrosive liquids and vapors.

This can occur when substances such as H<sub>2</sub>S, (hydrogen sulfide), Cl<sub>2</sub> (chlorine) or HCl (hydrochloric acid) are present. A dust cover may provide some limited protection. Routine calibration frequency should be increased in applications where corrosive materials are present.

3. Flame arrestor clogged as a result of painting or cleaning.

The routine maintenance procedure should include first powering down the system, then covering the sensor with a plastic bag when painting or cleaning. The bag should be removed as soon as possible when the procedure is complete. Recalibrate the sensors after re-powering and stabilization.

4. Polymer formation in the flame arrestor.

This can occur where monomeric vapors such as 1-3 butadiene, styrene, isoprene, etc. are present. This may render the sensor dead.

Some substances can cover or tie up the active sites on the catalytic surface of the active sensing element. This occurs in the presence of volatile metal organics, gases, hydride vapors, and volatile compounds containing phosphorous, boron, silicon, etc.

Examples: Tetraethyl lead  
Phosphine  
Diborane  
Silane  
Trimethylchlorosilane  
Hydrogen fluoride  
Boron trifluoride  
Phosphate esters  
Silicone oils and greases  
RTV silicone sealants

Some substances react with the catalytic element

metal, forming a volatile compound. This erodes the metal from the surface. With sufficient exposure, most or all of the metal catalyst can be removed from the surface of the active element of the sensor. Halogens and compounds that contain halogens are materials of this nature.

- Examples:
- Chlorine
  - Bromine
  - Iodine
  - Hydrogen Chloride, Bromide or Iodide
  - Organic halides
  - Trichloroethylene
  - Dichlorobenzene
  - Vinyl chloride
  - Freons
  - Halon 1301 (Bromotrifluoromethane)

A brief exposure to any of these materials may temporarily increase the sensitivity of the sensor due to etching of the catalytic surface. This practice is not recommended, since it is unreliable and may give a false sense of security.

Exposure to high concentrations of gas for extended periods can introduce stress to the sensing element and seriously affect its performance. After exposure to a high concentration of combustible gas, re-calibration should be performed and, if necessary, the sensor should be replaced.

The degree of damage to a catalytic sensor is determined by the type of contaminant, its concentration in the atmosphere, and the length of time the sensor is exposed. When a sensor has been exposed to a contaminant or to a high level of combustible gas, it should be re-calibrated at the time, followed by an additional calibration a few days later to determine whether a significant shift in sensitivity has occurred.

## INSTALLATION WIRING REQUIREMENTS

The simplest installation involves installing the sensor into one of the UD30 ports and connecting the wiring directly to the CGS Conditioning Board.

## SENSOR SEPARATION

If the installation requires separation of the CGS sensor and the UD30 Display, the sensor can be connected to a model STB sensor termination box, and the CGS/STB combination wired to the UD30.

In this case, shielded cable is recommended to help protect against interference caused by extraneous electrical “noise.”

In applications where the cable is installed in conduit, the conduit should not be used for wiring to other electrical equipment, whenever possible. If other equipment power

wiring is run in the same conduit; the cabling **must** be shielded.

**The maximum allowable distance between the CGS sensor and the UD30 is 500 feet, with connecting cable 16 AWG, 1.5 mm<sup>2</sup> minimum. See additional information in the table below.**

Table 1	Maximum Transmitter to Sensor Distance	
	Feet	Meters
Wire Size (AWG)		
20	195	59
18	325	99
14 - 16	500	152

## INSTALLATION AND WIRING PROCEDURE

1. Determine the best mounting locations for the detector.
2. Install the CGS sensor within the proper port in the UD30 or STB junction box. Mount the device with the sensor oriented vertically pointing down.
3. Terminate all wiring at the proper terminals.
4. Double-check that all wiring is the proper size and type and has been installed correctly. Check for proper operating voltage at the device.

### NOTE

Do not apply power to the system with the junction box cover removed unless the area has been de-classified.

## DETECTOR SELECTION

Select detector via the UD30 menu  
MAN MENU>SETUP>SETUP WIZARD>CGS.

## CALIBRATION

### NOTE

*For maximum calibration accuracy, allow a new sensor to operate under power for several hours (minimum 1 hour) to ensure a stable output before performing calibration. For the highest degree of accuracy, perform a second calibration after 24 hours.*

To initiate calibration of the CGS sensor, use the magnet tool to navigate the UD30 Display:

1. MAIN MENU>CALIBRATION>START CALIBRATION (ENTER).

2. The UD30 will display “Apply Zero Gas Zero,” and the backlight changes to steady yellow, as Zero calibration is initiated.
3. The message changes to “Waiting for Zero” as it performs Zero Calibration.
4. When Zero Calibration is complete, the UD30 will display “Waiting For Gas.”
5. Apply Calibration gas.
6. The UD30 will display “Waiting for Span,” and the backlight flashes Yellow while Span calibration is being performed.
7. When the UD30 displays “Remove Cal Gas,” remove the calibration gas from the sensor.
8. The UD30 will display the message “Calibration complete” and return automatically to Normal state with the Backlight color changing to Green.

**NOTE**

*Must include calibration intervals and maximum time between calibrations. Details for maintenance if calibration measuring ranges are exceeded.*

**K FACTOR**

If the detector will be detecting a gas other than certified Methane or Propane, a conversion K-Factor must be used for the gas used in the calibration process.

The K-Factor can be entered prior to calibration by navigating the UD30 menu: MAIN MENU>SETUP>K-Factor. Enter the desired K-Factor and select the ENTER switch. The new K-Factor will be applied when the sensor is calibrated.

The effect of the K-Factor can be observed as the span portion of the calibration is completed. For example, suppose a K-Factor of 0.865 has been programmed when the calibration is performed the UD30 will display 50% as span is accepted. It will then apply the K-Factor and the displayed value will change to 43.3% LFL.

For additional information regarding K-Factors, including a list K-Factors for many common gases, refer to Technical Bulletin number: 76-1017.



FlexSonic® Acoustic  
Leak Detector



X3301 Multispectrum  
IR Flame Detector



PointWatch Eclipse® IR  
Combustible Gas Detector



FlexVu® Universal Display  
with GT3000 Toxic Gas Detector



Eagle Quantum Premier®  
Safety System

Specifications subject to change without notice.

All trademarks are the property of their respective owners.  
© 2021 Carrier. All Rights Reserved.

Det-Tronics manufacturing system is certified to ISO 9001—  
the world's most recognized quality management standard.



**Corporate Office**  
6901 West 110<sup>th</sup> Street  
Minneapolis, MN 55438 USA  
[www.det-tronics.com](http://www.det-tronics.com)

Phone: +1 952.941.5665  
Toll-free: +1 800.765.3473  
Fax: 952.829.8750  
det-tronics@carrier.com