

# Instructions

FlexSight™ LS2000 Line-of-Sight  
Infrared Hydrocarbon Gas Detector

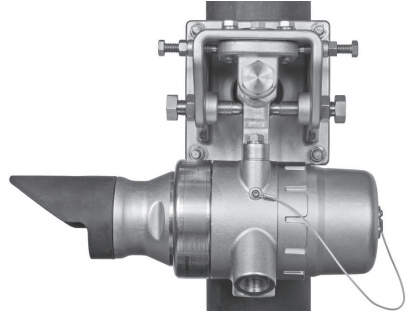
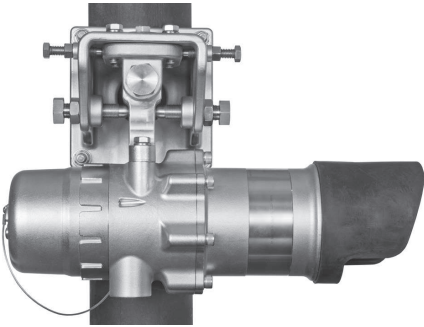

# Table of Contents

APPLICATION .....	1	ALIGNMENT .....	25
OPERATION OVERVIEW .....	2	Overview .....	25
Theory of Operation .....	2	Equipment Required .....	25
Detectable Gases .....	2	Alignment Procedure .....	26
Detection Ranges .....	2	Aperture Kit for Short Range Applications .....	28
Standard Output .....	2	Recommendations for using the HART Field Communicator .....	28
LON Output .....	2	Communicator .....	28
Optional Relays .....	4	Gain Level Check .....	29
EQP Version .....	4	Transmitter Lamp Voltage .....	29
Optional Communication Link .....	4	CALIBRATION .....	30
History Logs .....	4	Calibration Overview .....	30
OPERATION .....	5	Zero Calibration .....	30
Internal Magnetic Switch/Calibration Line Terminal .....	5	Important Calibration Notes .....	30
Module Identification .....	5	Calibration Initiation .....	30
Factory Reset Command .....	5	Calibration Sequence .....	30
Operating Modes .....	6	MAINTENANCE .....	31
4-20 mA Current Loop Output .....	6	Routine Inspection .....	31
Heater Control .....	7	Optics Cleaning .....	31
Status and Fault Indication and Troubleshooting .....	8	Functional Checking .....	31
SPECIFICATIONS .....	12	Protective Caps and Covers .....	31
IMPORTANT SAFETY NOTES .....	15	REPLACING LS2000 TRANSMITTER/ RECEIVER ELECTRONICS MODULE .....	32
INSTALLATION .....	16	Module Replacement Procedure .....	32
Identification of Vapor(s) to be Detected .....	16	DEVICE REPAIR AND RETURN .....	34
System Location Considerations .....	16	ORDERING INFORMATION .....	34
Module Mounting Recommendations .....	17	Alignment Equipment .....	34
Replacing an Existing Model OPECL with an LS2000 .....	20	Accessories .....	34
24 Vdc Power Supply Requirements .....	20	Spare Parts .....	34
Wiring Cable Requirements .....	20	Assistance .....	34
Power Wiring Size and Maximum Length .....	21	APPENDIX A - FM APPROVAL DESCRIPTION .....	36
Optional Relays .....	21	APPENDIX B - CSA CERTIFICATION DESCRIPTION .....	38
Wiring Procedure .....	21	APPENDIX C - ATEX APPROVAL DESCRIPTION .....	40
STARTUP .....	25	APPENDIX D - IECEx APPROVAL DESCRIPTION .....	43
		APPENDIX E - ADDITIONAL APPROVALS .....	46
		APPENDIX F - HART COMMUNICATION .....	48
		APPENDIX G - EAGLE QUANTUM PREMIER MODEL .....	51

## FlexSight™ LS2000 Line-of-Sight Infrared Hydrocarbon Gas Detector



### IMPORTANT

Be sure to read and understand the entire instruction manual before installing or operating the gas detection system. This product is intended to provide early warning of the presence of a flammable or explosive gas mixture. Proper device installation, operation, and maintenance is required to ensure safe and effective operation.

### APPLICATION

The FlexSight™ Line-of-Sight Infrared Hydrocarbon Gas Detector Model LS2000 is a line-of-sight infrared gas detection system that provides continuous monitoring of combustible hydrocarbon gas concentrations in the range of 0 to 5 LFL-meters, over a distance of 5 to 120 meters. Standard system outputs include an electrically isolated/non-isolated 4–20 mA dc current output with the ability to go below 4 mA to indicate fault conditions, and also HART and RS-485 Modbus communication. Alarm and fault relays are available as an option.

System outputs are dependent upon the specific features of your detector. Please refer to the Ordering Information portion of this manual for more information.

The system consists of two stainless steel modules — a transmitter and a receiver, along with mounting and alignment bracket. The receiver provides the measurement signal outputs, and is furnished with onboard “status indication” LEDs and an internal magnetic calibration switch. The transmitter houses a high quality xenon flash lamp and “status indication” LEDs. Both modules are powered from an external 24 volt DC supply and are equipped with microprocessor controlled heated optics to increase resistance to moisture and ice. Both modules must be installed at approximately the same elevation and must be aligned to point directly at one another. No direct electrical interconnection between the two modules is required.

The LS2000 is certified explosion-proof for use in Class I, Division 1; Class II/III, Division 1; Class I, Division 2, Class II/III, Division 2; Class I, Zone 1; Ex db IIC T4 or Ex db eb IIC T4. The detector also has third party performance certification for methane, butane, and propane gas detection. It can be used as a stand-alone detector, or as part of a larger facility protection system using other Det-Tronics equipment such as the Eagle Quantum Premier® (EQP) Fire and Gas Safety system. See the EQP Safety System instruction manual for more information (95-8533).

# OPERATION OVERVIEW

## THEORY OF OPERATION

The LS2000 transmitter module uses a Xenon flash lamp to produce a collimated IR light source. This light source illuminates the path between transmitter and receiver. The transmitter uses a filter to block visible light emissions and is eye safe.

As flammable hydrocarbon gases intersect the light beam between the two modules, certain IR wavelengths are absorbed by the gas, while other IR wavelengths are not. The amount of IR absorption is determined by the concentration of the hydrocarbon gas. A pair of optical detectors and associated electronics located in the receiver module measure the absorption. The change in intensity of the absorbed light (active signal) is measured relative to the intensity of light at a non-absorbed wavelength (reference signal). The microprocessor computes the gas concentration and converts the value into a 4-20 mA current output signal, which is then communicated to external control and annunciation systems.

The gas concentration is indicated by a 4-20 mA signal or LON communication, which corresponds to 0-5 LFL-meters. To better understand the concept of LFL-meters, refer to Figure 1, which shows how three gas clouds of different size and concentration would produce the same output of 1 LFL-meter by the line-of-sight gas detection system. To convert a given LFL-m value to ppm-m for methane, propane, or butane gas, refer to Table 1.

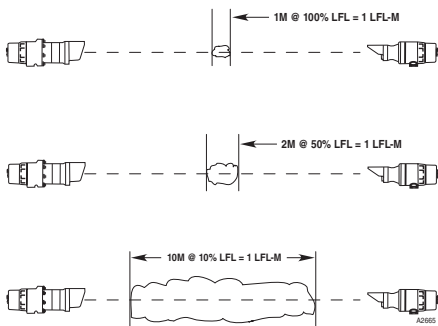

LS2000 OUTPUT EQUALS 1 LFL-M IN ALL THREE SCENARIOS

Figure 1—Detector Response to Three Gas Clouds of Different Size and Concentration

## DETECTABLE GASES

The LS2000 is capable of detecting hydrocarbon gases and vapors including methane, propane, and butane. Gas type and other operational parameters are selected via HART, Modbus, or LON communication. The LS2000 is factory calibrated to methane, propane, and butane. The user can select the factory set calibrated gas upon ordering and can manually convert the device to accurately read one of the three gases at any time. For detection of gases other than the three selection settings (methane, propane, and butane), performance characteristics / transfer curves are available. Please contact the factory for details.

## DETECTION RANGES

The LS2000 is offered in two detection ranges in order to meet customer needs, as listed below:

Short Range	5-60 meters
Long Range	30-120 meters

For installations with short separation distances (5-15 meters for the short range model and 30-40 meters for the long range model), the range reduction aperture kit (supplied) is required. Refer to "Aperture Kit for Short Range Applications" section in this manual for details.

The correct range for the LS2000 must be chosen to meet specific application needs. The detection range of the LS2000 pair is determined by the Receiver. Receiver units can be converted from long to short or short to long range in the field by replacing the front electronics module. A single transmitter model is used for both detection range options.

## STANDARD OUTPUT

The LS2000 receiver module provides an analog 4-20 mA signal output. HART and RS-485 Modbus serial communication are available at either module. The 4-20 mA current loop corresponding to 0-5 LFL-meters is provided for connection to analog input devices such as gas controllers, logic controllers, or distributed control systems (DCS). To convert the mA reading to LFL-meters, use the following formula:

$$\frac{\text{mA Reading} - 4}{16} \times 5 = \text{LFL-Meters}$$

## LON OUTPUT

The LON version of the LS2000 receiver module provides a digital output. HART and RS-485 Modbus serial communications are also available at the receiver and transmitter. The gas level is transmitted digitally to the EQP controller corresponding to 0-5 LFL-meters, along with diagnostic information.

Table 1—LFL-m to PPM-m Conversion

Gas	Path Length (m)	Cloud Concentration (LFL)	Cloud Concentration (v/v, by volume)		Cloud Concentration (ppm)	LFL-m	ppm-m
			per ISO/NFPA 497	per IEC			
Methane	1	100%	5.0%	4.4%	50000	1	50000
Methane	2	100%	5.0%	4.4%	50000	2	100000
Methane	3	100%	5.0%	4.4%	50000	3	150000
Methane	4	100%	5.0%	4.4%	50000	4	200000
Methane	5	100%	5.0%	4.4%	50000	5	250000
Propane	1	100%	2.2%	1.7%	22000	1	22000
Propane	2	100%	2.2%	1.7%	22000	2	44000
Propane	3	100%	2.2%	1.7%	22000	3	66000
Propane	4	100%	2.2%	1.7%	22000	4	88000
Propane	5	100%	2.2%	1.7%	22000	5	110000
Butane	1	100%	1.9%	1.4%	19000	1	19000
Butane	2	100%	1.9%	1.4%	19000	2	38000
Butane	3	100%	1.9%	1.4%	19000	3	57000
Butane	4	100%	1.9%	1.4%	19000	4	76000
Butane	5	100%	1.9%	1.4%	19000	5	95000

NOTE: "A" (FM/CSA) variant is factory calibrated to ISO/NFPA 497 and the "E" or "B" (IEC/ATEX) variant is factory calibrated to IEC.

## OPTIONAL RELAYS

The LS2000 can be furnished with factory installed relays — two programmable alarm relay outputs and one fault relay output. All relays are sealed and provide form C (NO/NC) contacts. The high and low alarm relays are programmable, and can be set for latching / non-latching operation, and a normally energized / de-energized coil (see Table 3). The low alarm cannot be set above the high alarm threshold. Alarm configuration can be done with the HART or Modbus interface. The onboard multi-color LEDs indicate a LOW alarm condition via a flashing red color, and a HIGH alarm condition via a steady red color. Latched alarms can be reset using the internal magnetic switch, an external switch connected to the calibration line terminal, a HART Field Communicator, or Modbus communication. A short-duration magnetic switch activation of one second will reset latched alarms. Holding the magnetic switch closed for a three second duration will start the calibration sequence.

When the optional relays are ordered, the LS2000 receiver is certified for Ex d operation. Alarm relays are not available with the LON version.

## EQP VERSION

The Eagle Quantum Premier model provides proprietary digital signals that are compatible with the EQP network. No analog 4–20 mA signal output is provided. Modification of alarm thresholds, latching / non-latching settings, and gas type should be configured on the S<sup>3</sup> point configuration software. S<sup>3</sup> has the capability to rewrite configurations completed on HART and Modbus communications. The onboard HART and Modbus RS-485 RTU communications are operational and can be used to modify certain settings without the chance of a rewrite, specifically the heater settings. Refer to the EQP Appendix within this manual for additional information.

## OPTIONAL COMMUNICATION LINK

By connecting the transmitter and receiver via a three-wire shielded cable, an optional “communication link” can be created between the two devices.

The communication link offers the following advantages:

1. Single point system diagnostics – The link offers the ability to view device variables of the receiver while connected to the transmitter, or vice versa (using a HART handheld or Modbus device). These variables include signal

strength, status, and configuration parameters such as alarm set points, heater settings, gas type, etc.

2. Dynamic lamp power – The link enables the system to optimize lamp power per the application. This optimization only happens during the zero calibration process.
3. Synchronized LEDs on each device can signal a common system status condition. Without the link, the transmitter is unable to signal alarm status.
4. Transmitter variables can be configured via connection to the receiver. Refer to Appendix F, HART Communications, for details.

### NOTE

Alarm setpoints in the receiver cannot be changed from the transmitter.

5. The communication link provides the ability to initiate Calibration from either the transmitter or receiver.

For retrofit applications where an inter-connecting wire is not available or possible, the system can operate without the link. If the link is not connected, the system will not indicate a “link fault.”

A “link fault” feature can be enabled (using a HART handheld or Modbus device), which will indicate a fault if the link is broken. The “link fault” can only be detected and announced by the receiver.

### NOTE

The default setting for the “link fault” feature is Disabled.

### NOTE

All third-party performance and hazardous location approvals apply with and without the communication link connected.

## HISTORY LOGS

Non-volatile memory is provided in the receiver to save a record of the 100 most recent calibrations and 1000 most recent alarm/fault events. Operating temperature and voltage of the receiver are also recorded with each event log. A real time clock is provided for time stamping events. This information is accessible using HART or Modbus communication.

## OPERATION

### INTERNAL MAGNETIC SWITCH / CALIBRATION LINE TERMINAL

An internal magnetic switch is provided for resetting latched alarms and initiating field zero calibration. See Figure 2 for switch location. The same functions can be accomplished remotely by installing a switch (momentary closure) between the CAL and 0V COM terminals on the LS2000 receiver. Momentary switch activation will reset alarms, while holding the switch closed for three seconds or longer (not to exceed 30 seconds) will start the calibration sequence. The LEDs will begin flashing green (5 Hz) when the reset criteria have been met and will change to flashing yellow (5 Hz) when the calibration period has been met (>3 seconds, <30 seconds). The device will reset if the switch is released during a flashing green LED and will enter calibration if the switch is released during a flashing yellow LED.

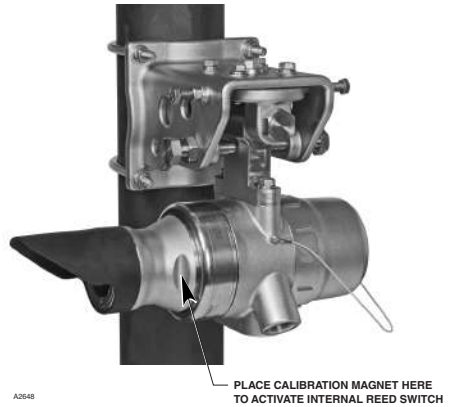

Figure 2—Location of Internal Magnetic Switch on Receiver Module

### MODULE IDENTIFICATION

See Figure 3 for identification of the transmitter and receiver modules. The functional and electrical characteristic differences of the two devices are described in Table 2.

### FACTORY RESET COMMAND

The LS2000 provides a factory reset command that sets all user configurable parameters back to their default settings. This command can be accessed via HART or Modbus communication.

Table 2—Functional and Electrical Comparison of Transmitter and Receiver

Characteristic	Transmitter	Receiver
Functional Description	Contains a xenon flash lamp, and generates optical energy to enable hydrocarbon detection.	Contains opto-electronics, signal processing, output drivers, and diagnostic electronics.
Electrical Connections	Connections for power, HART, RS-485, Communication Link.	Connections for power, 4–20 mA, HART, RS-485, relay contacts (optional), LON communication, Communication Link, and calibration/reset.
Onboard LED Indicators	Indicates device status. Green indicates normal operation. Yellow indicates fault condition. When the Communication Link is used, the transmitter LED operation matches receiver LED operation, including alarm status.	Indicates normal, alarm, fault, and calibration status. Green indicates normal operation. Blinking red indicates low gas alarm condition. Steady red indicates high gas alarm condition. Yellow indicates system fault. See Tables 4 and 5 for details. LED operation for fault status is non-latching. LED operation for gas alarms is configurable for latching/non-latching.
Magnetic Calibration Switch (See Figure 2 for switch location.)	NA	Momentary activation provides reset function for latched alarm outputs. Activation for longer than 3 seconds will initiate zero calibration.
Adjustable Settings	Programmable IR signal intensity and heater operation. HART or Modbus communication is required to change the factory default settings.	Factory calibrated for methane, propane, and butane, 0-5 LFL-meters full scale. Default gas depends on model. See Table 3 for receiver factory default settings. HART, Modbus, or LON communication is required to change the factory default settings.

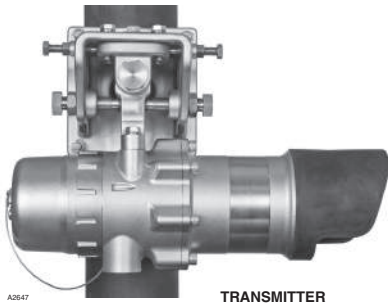

A2647

**TRANSMITTER**

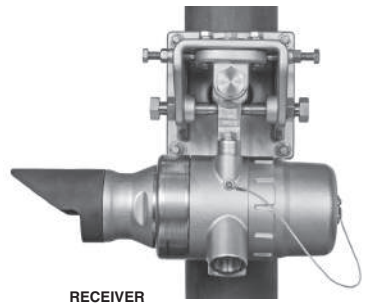

**RECEIVER**

Figure 3— Identification of Transmitter and Receiver Modules

**OPERATING MODES**

The LS2000 has three operating modes: warm-up, normal (measuring / monitoring), and calibrate.

**Warm-up**

Warm-up mode is entered upon application of 24 Vdc operating power. During warm-up, the 0-20 mA current loop output will indicate warm-up, the indicating LED is yellow, and the alarm outputs are disabled. The warm-up time typically lasts from 15 to 150 seconds, depending upon alignment accuracy.

**Normal**

After warm-up mode is completed, the device automatically enters the Normal mode, and all analog and alarm outputs are enabled. The LS2000 modules must be properly aligned before normal operation is attained. See the "Installation" section of this manual for details.

**Calibrate**

After alignment is completed, zero calibration is required. Span calibration of the LS2000 is performed at the factory; however, the user has the option to verify proper calibration if necessary. It is recommended that the zero calibration procedure be performed annually. Refer to the "Calibration" section in this manual for details.

Table 3—Factory Default Settings

	Default	Configurable Options
Gas Type	Methane	Methane, Propane, Butane
Low Alarm Threshold (LFL-M)	1	0.5 to 4.5 (10% to 90%)
High Alarm Threshold (LFL-M)	3	0.5 to 4.5 (10% to 90%)
High & Low Alarm Relays (Optional)	Non-Latching, De-Energized	Latching/Non-Latching, Energized/De-Energized
Beam Block Delay	60 Seconds	60–3600 Seconds
Fault Mode	LS2000	LS2000, Advanced, User Defined
Heater Mode*	Smart Mode	Smart Mode, Always On, Always Off

\*See "Heater Control" section for details.

NOTE: The system must be configured for less than 60% of the full scale measuring range, with consideration to the accepted gas cloud size and concentration.

**4-20 MA CURRENT LOOP OUTPUT**

The LS2000 provides a linear current loop output that is proportional to the detected gas level. Fault and calibration status are also indicated by this output.

The full-scale output corresponding to 5 LFL-meters is 20 mA. HART and Modbus interfaces also have the ability to calibrate (trim) the 4 mA and 20 mA levels. Refer to Appendix F, HART Communications, for details.

The LS2000 is equipped with output monitoring circuitry for the current loop and will indicate a fault when the output mA level does not match the output set point of the device. This monitoring (disabled by default) will indicate a fault if the current loop is not terminated correctly. The loop monitoring feature can be enabled via HART or Modbus communication.

The LON version does not have a 4–20 mA output.



Table 4—LS2000 Receiver Status Conditions

Status	4-20mA Output			Relays		LED
	LS2000 Default	Advanced	User Defined	Fault Relay	Alarm Relays	
Warm up	1.0	1.0	Detection Disabled	De-energized	Disabled	Yellow - Solid
Normal	4.0 to 20.5	4.0 to 20.5	4.0 to 20.5	Energized	Enabled	Green - Solid = Normal Red - Flashing = Low Alarm Red - Solid = High Alarm
Zero Calibration	1.0	2.2	Configuration	Energized	Disabled	Yellow - Flashing @ 5 Hz

Note: When the Communication Link is used, the transmitter LED operation matches receiver LED operation, including alarm status.

HEATER CONTROL

Table 5—Typical LS2000 Window Temperature Rise (Degrees C) for Various Heater Settings and Ambient Temperatures

The LS2000 optics in both transmitter and receiver are heated to provide moisture and ice resistance. These heaters are microprocessor controlled and can be configured to operate in the following modes:

- Always On
- Always Off
- Smart Mode (default)

- 1) Heaters maintain a user programmable turn on temperature set point (default = 50°C).
- 2) Heaters increase to full power when signal strength is degraded due to moisture or condensation on the window, or any obscuration faults are active.
- 3) Heaters shut off when the input voltage drops below a user defined cut off voltage level (default = 18.5 Vdc).
- 4) Heater power usage can be limited from 0-100% (default uses up to 100% power if needed). See the table in the Specifications section for power consumption details.

LS2000 Window Temperature Rise (C)		AMBIENT TEMPERATURE			
		-55°C	-40°C	0°C	25°C
30% Heater Setting	Receiver	5.1	5.3	4.5	3.0
	Transmitter	4.2	4.1	4.2	3.0
50% Heater Setting	Receiver	7.2	6.8	7.0	5.0
	Transmitter	5.3	5.2	5.3	3.6
70% Heater Setting	Receiver	9.8	9.1	7.5	7.1
	Transmitter	7.8	6.6	5.1	3.8
100% Heater Setting	Receiver	15.8	14.9	8.6	7.3
	Transmitter	13.3	10.6	5.9	4.5

Table 5 indicates the typical window glass temperature rise for various heater setting and ambient temperature combinations.

NOTE

Higher heater settings reduce or eliminate moisture buildup on the window, thereby providing optimum detector performance.

## STATUS AND FAULT INDICATION AND TROUBLESHOOTING

Status and fault conditions are indicated using the 4–20 mA analog signal output. Signaling modes include two predefined modes, and a user defined mode for third party compatibility. The user defined mode allows users to define a mA output level (range 1.0 - 3.6 mA) for each of the three status / fault categories: configuration, advisory, and detection disabled. Refer to Table 4 for status indications and Table 6 for fault conditions and troubleshooting guidance. Status and fault indication configuration options can be changed via HART or Modbus communication.

### NOTE

Transmitter warm-up and fault conditions are indicated by a solid yellow LED, and diagnostics can be performed using HART or Modbus RTU communication. The receiver will continue to perform its safety function, and will indicate a fault status if normal operation has been compromised. Transmitter fault and status can be read from the receiver HART and Modbus ports once the communication link is active. See the "Optional Communication Link" section of this manual for more information.

If a transmitter fault occurs, perform normal maintenance and ensure correct input voltage at the device. If normal operation cannot be restored, contact Technical Support.

Table 6—LS2000 Receiver Troubleshooting Guide

Receiver Fault Condition	4-20mA Output			Relays	LED
	Default	Advanced	User Defined	Fault Relay	
Output loop fault	0.0	0.0	0.0	De-energized	Yellow - Solid for 10 seconds, followed by 1 Pulse
RAM Fault	1.0	1.2	Detection Disabled	De-energized	Yellow - Solid
Data Flash Fault	1.0	1.2	Detection Disabled	De-energized	Yellow - Solid
Flash CRC Fault	1.0	1.2	Detection Disabled	De-energized	Yellow - Solid
AFE Fault	1.0	1.2	Detection Disabled	De-energized	Yellow - Solid
Internal Voltage Fault	1.0	1.2	Detection Disabled	De-energized	Yellow - Solid
Active Sensor Saturated	1.0	1.2	Detection Disabled	De-energized	Yellow - Solid
Reference Sensor Saturated	1.0	1.2	Detection Disabled	De-energized	Yellow - Solid
Input Voltage Low	1.0	1.4	Advisory	De-energized	Yellow - Solid for 10 seconds, followed by 2 Pulses
Input Voltage High	1.0	2.0	Advisory	De-energized	Yellow - Solid for 10 seconds, followed by 8 Pulses
Heater Fault	1.0	1.6	Advisory	De-energized	Yellow - Solid for 10 seconds, followed by 3 Pulses
Interconnect Link Fault	1.0	1.8	Advisory	De-energized	Yellow - Solid for 10 seconds, followed by 4 Pulses
Zero Calibration Fault	1.0	2.4	Advisory	De-energized	Yellow - Solid for 10 seconds, followed by 5 Pulses
Calibration Line Low Fault	1.0	2.6	Advisory	De-energized	Yellow - Solid for 10 seconds, followed by 6 Pulses
Beam Block	2.0	2.8	Detection Disabled	De-energized	Yellow - Solid for 10 seconds, followed by 7 Pulses
Low Signal Fault	3.0	3.2	Advisory	De-energized	Yellow - Solid for 10 seconds, followed by 9 Pulses
Zero Drift (-9% of Scale?)	1.0	3.6	Advisory	De-energized	Yellow - Solid for 10 seconds, followed by 10 Pulses
Over Range	20.5	20.5	20.5	Energized	Red - Solid
Span Cal Fault	1.0	2.4	Advisory	De-energized	Yellow - Solid for 10 seconds, followed by 5 Pulses

NOTE: The device will always attempt to override the fault condition if an alarm condition occurs including "Detection Disabled" faults

Table 6—LS2000 Receiver Fault Troubleshooting Guide (Continued)

Receiver Fault Condition	Condition	Recommended Action
Output Loop Fault	The 4-20 mA output loop is not functioning properly; the output mA level does not match the output set point of the device.	Check field wiring, termination points, and resistance of the 4-20 mA loop. Ensure that the 4-20 mA output terminal of the LS2000 Receiver is connected to ground through an appropriate sized load (see instruction manual for details).
RAM Fault	System RAM test failed.	Cycle power to the unit. (If problem does not clear, contact factory.)
Data Flash Fault	Data can no longer be read/written to flash memory inside the processor.	Cycle power to the unit. (If problem does not clear, contact factory.)
Flash CRC Fault	Non-Volatile Memory Operation Failed.	Cycle power to the unit. (If problem does not clear, contact factory.)
AFE Fault	Receiver gain circuit failed.	Cycle power to the unit. (If problem does not clear, contact factory.)
Internal Voltage Fault	Internal step-down power supply out of range condition.	Cycle power to the unit. (If problem does not clear, contact factory.)
Active Sensor Saturated	Active sensor is receiving too much light intensity from transmitter.	1. For installation with module separation distances between 5 and 40 meters, the range reduction aperture kit (supplied) is required. 2. Transmitter lamp voltage should be lowered to reduce signal to receiver.
Reference Sensor Saturated	Reference sensor is receiving too much light intensity from transmitter.	1. For installation with module separation distances between 5 and 40 meters, the range reduction aperture kit (supplied) is required. 2. Transmitter lamp voltage should be lowered to reduce signal to receiver.
Input Voltage Low	Supply voltage to LS2000 is less than 16V.	Supply voltage needs to rise above 16V. Check supply voltage and power wiring.
Input Voltage High	Supply voltage to LS2000 is greater than 33V.	Supply voltage needs to drop below 33V. Check supply voltage and power wiring.
Heater Fault	Heater is not working.	Fault will clear if heater is configured to be off. If heater is required, contact factory for repair.
Interconnect Link Fault	If communication link is being used, communication has been lost between receiver and transmitter. (Annunciation of this status condition is configurable and is disabled by default.)	Check field wiring and ensure that the Rx/TX communication link lines are connected as specified in the instruction manual. Return unit to factory if problem persists.
Zero Calibration Fault	This fault will persist through power cycle until a successful calibration is completed; calibration will time out at 10 minutes	If the calibration process is allowed to time out, the fault is set and can only be reset with a successful calibration.
Calibration Line Low Fault	Zero calibration line is pulled low during power up, resulting in a Zero Calibration active during power-up.	1. Check receiver wiring to verify any wired connection to terminal 6 (Reset/Cal) is not connected to ground. 2. Upon power-up of the unit, make sure a magnet is not positioned very close to the receiver bulkhead area where magnetic switch resides.
Beam Block	The receiver doesn't see the light signal from the transmitter continuously for 1 minute or the time set by user (Min 1 minute, Max 6 hours, default 1 minute)	1. Clear beam obstruction. 2. Check alignment and re-align if necessary.
Low Signal Fault	Indicated when the received light intensity is below 30% of full scale at gain 100.	1. Clean windows of receiver and transmitter. 2. Check alignment and re-align if necessary.
Zero Drift -9% of Scale	A constant under range condition where the gas reading is at or below -10% of full scale reading for a period of one minute or more. (Gas detection is still enabled, but output reading will be lower than actual gas concentration applied.)	1. Zero calibration in clean air environment. 2. Dense fog may be in beam path.
Over Range	Overrange condition is indicated by a steady 20.5 mA output, as this is maximum gas concentration that will be displayed.	Gas is likely present in high concentration; react accordingly.

Table 6—LS2000 Receiver Fault Troubleshooting Guide (Continued)

Fault Condition	Corrective Action
Other Faults	Refer to Appendix F for descriptions of messages and information available when using a HART device.

## SPECIFICATIONS

**OPERATING VOLTAGE (Both Modules)—**  
24 Vdc nominal. Operating range is 18 to 30 Vdc.  
Ripple cannot exceed 0.5 volts P-P.

### POWER CONSUMPTION—

Power Consumption (Watts)			
		Transmitter Maximum	Receiver Maximum
@ 24 Vdc	Total Unit, No Heaters or Relays	6.5	2.6
	30% Heater Only	1.4	1.1
	50% Heater Only	2.5	2.0
	70% Heater Only	3.5	2.7
	100% Heater Only	4.2	3.3
	Relay Only	N/A	1.2
	Total Unit, Max	10.7	7.2
@ 30 Vdc	No Heaters or Relays	6.5	2.9
	30% Heater Only	2.3	1.8
	50% Heater Only	4.2	3.1
	70% Heater Only	5.9	4.2
	100% Heater Only	7.2	5.1
	Relay Only	N/A	1.2
	Total Unit, Max	13.7	9.2
@ 33 Vdc*	Total Unit, Max	16.0	10.0

\* Per regulatory approval requirements, the unit power consumption was measured at 33 VDC input voltage (10% above claimed range) and results listed on the product label.

### TRANSMITTER LAMP—

Xenon flashlamp, field-replaceable module (10 yr warranty).

### WARMUP TIME—

15 seconds minimum, 150 seconds maximum from power-up, depending upon alignment accuracy.

### CURRENT OUTPUT—

Linear 4-20 mA (isolated/non-isolated) rated at 600 ohms maximum loop resistance @ 24 Vdc operating voltage, with the ability to go below 4 mA to indicate a fault condition.

### RELAY OUTPUTS (Optional)—

Available on Ex d approved models only.

### ALARM RELAYS—

Low and High  
Form C Type (NO/NC). De-Energized during Normal mode, Energized on Alarm.

Contact Rating: 3 amperes at 30 Vdc.  
Programmable for Latching or Non-Latching Operation.

Low Alarm: 0.5 to 4.5 LFL-meters  
(default = 1 LFL-meters, Non-latching).

High Alarm: 0.5 to 4.5 LFL-meters  
(default = 3 LFL-meters, Non-latching).

Alarm relays are programmable using HART or Modbus communication.

### CAUTION

When the LS2000 Gas Detector is used in conjunction with an appropriate certified Control Unit and configured for a non-latching high alarm, the control unit must always latch and require a deliberate manual action to clear a high gas alarm. When used as a stand alone device, the high alarm must always be programmed for latching operation.

### FAULT RELAY—

Form C Type (NO/NC).  
Energized during Normal mode, De-Energized on Fault or loss of power.

Contact Rating: 3 amperes at 30 Vdc.  
Non-Latching Operation only — not programmable.

### VISUAL STATUS INDICATOR—

LEDs – Transmitter:

Red = Low alarm, high alarm\*  
Green = Power on / OK  
Yellow = Fault / warmup / calibration\*

\*Communication link required for low / high alarm and calibration indication.

LEDs – Receiver:

Red = Low alarm, high alarm  
Green = Power on / OK  
Yellow = Fault / warmup / calibration

See Tables 4 and 5 for details.

### AVAILABLE GAS SETTINGS—

Third party performance approved to methane, butane, and propane.

### DETECTION RANGE—

Short Range 5-60 meters  
Long Range 30-120 meters.

Note: It may be necessary to add the aperture (supplied) to the transmitter when operating at the lower 10-15 meters of each range.

### MISALIGNMENT TOLERANCE—

±0.8 degree minimum (~±56cm @ 40m; ~±168cm @ 120m). The LS2000 is third party verified to maintain specified accuracy within the entire 0.8 degree field of view for both Receiver

and Transmitter.

Note: The receiver has a circular field of view. The transmitter has an oval shaped field of view with a minimum 0.8 degree tolerance along the horizontal axis and a minimum 1.5 degree tolerance along the vertical axis (Det-Tronics verified).

#### CALIBRATION—

LS2000 systems are span calibrated for methane, propane, and butane at the factory. Span calibration in the field is not required (see Table 1 for factory span calibration concentration by variant).

Zero calibration is accomplished in the field by one of the following methods:

- On-board magnetic reed switch
- Modbus communication
- HART communication
- External calibration switch
- LON communication

#### RESPONSE TIME—

Refer to the appropriate Approval/Certification Appendix for details.

#### ACCURACY—

Refer to the appropriate Approval/Certification appendix for details. Accuracy specification applies to full operating temperature, humidity, and pressure ranges listed, unless noted otherwise.

#### NOTE

**Further, misalignment reduces the accuracy of the detector. Refer to the appropriate Approval/Certification appendix for details.**

#### TEMPERATURE RANGE—

Operating:  $-55^{\circ}\text{C}$  to  $+75^{\circ}\text{C}$  ( $-67^{\circ}\text{F}$  to  $+167^{\circ}\text{F}$ )

Relay version:  $-55^{\circ}\text{C}$  to  $+65^{\circ}\text{C}$  ( $-67^{\circ}\text{F}$  to  $+149^{\circ}\text{F}$ )

Storage:  $-55^{\circ}\text{C}$  to  $+85^{\circ}\text{C}$  ( $-67^{\circ}\text{F}$  to  $+185^{\circ}\text{F}$ )

Hazardous Locations: Refer to the appropriate Approval/Certification Appendix for correct ambient temperature range.

#### HUMIDITY—

5 to 99% relative humidity; designed for outdoor applications.

#### OPERATING PRESSURE—

91.5 - 105.5 kPa non-compensated.

#### MEASUREMENT RANGE—

0-5 LFL-meters.

Note: A Negative Zero Drift fault is indicated at  $-9\%$  of full scale.

#### INTERFERENCE RESISTANCE—

Immune to sun and flare radiation, tested to  $800 \pm 50 \text{ W/m}^2$  at  $\geq 3^{\circ}$  to optical axis and common contaminants.

#### SELF-DIAGNOSTIC TEST—

Fail-Safe operation ensured by performing all critical tests once per second.

#### MODULE HOUSING MATERIAL—

316 stainless steel (CF8M).

#### CONDUIT ENTRY OPTIONS—

3/4 inch NPT or M25, with two entries for transmitter and four entries for receiver.

#### OPTICS PROTECTION—

Microprocessor controlled heated optics mitigate against ice and dew formation. Brow provides a degree of protection against windblown dirt and rain. See "Mounting Instructions" for brow installation procedure.

#### INGRESS PROTECTION—

NEMA Type 4X certified, IP66/67

#### WIRING—

Field wiring screw terminals are UL/CSA rated for up to 14 AWG shielded wire, and are DIN/VDE rated for 2.5 mm<sup>2</sup> wire. Screw terminal required torque range is 3.5–4.4 lb.-in. (0.4-0.5 N-m).

The receiver can be wired using 3 or 4 wires. The transmitter requires two wires (power only). The use of shielded wiring is recommended.

Field wiring for supply connection must be rated to 95°C (203°F).

#### DIMENSIONS—

See Figure 4 for dimensions of the transmitter and Figure 5 for dimensions of the receiver.

#### MOUNTING & ALIGNMENT BRACKET

##### ADJUSTMENT RANGE—

$\pm 12$  degrees from center, both vertical and horizontal.

#### WARRANTY—

5 year limited warranty.

10 year warranty on IR source.

#### SHIPPING WEIGHT—

Transmitter and receiver with mounting hardware:  
85 pounds (38 kg)

Replacement Transmitter: 23 lbs (10.4 kg)

Replacement Receiver: 20 lbs (9 kg)

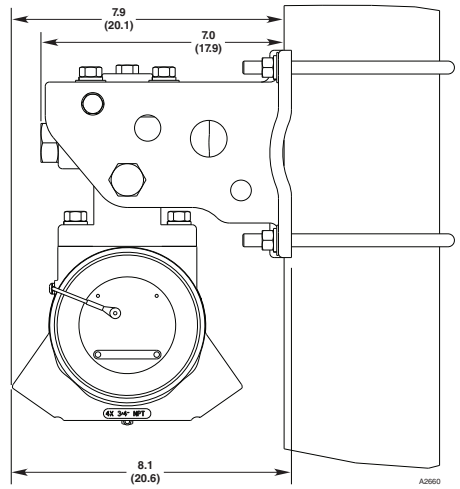
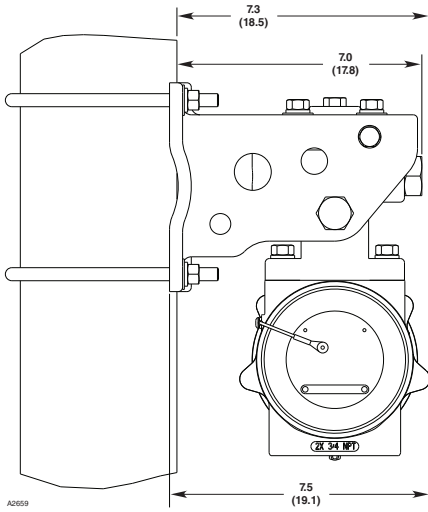
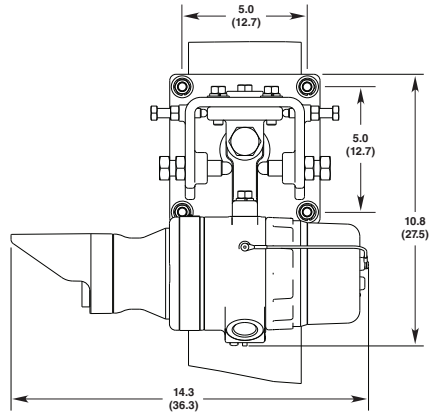
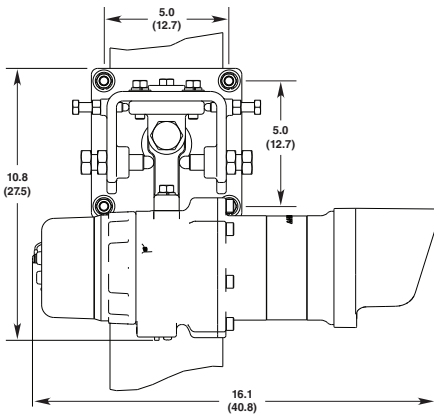

Figure 4—Mounted Dimensions of LS2000 Transmitter in Inches (cm)

Figure 5—Mounted Dimensions of LS2000 Receiver in Inches (cm)



Transmitter Electronics Module: 10.4 lbs (4.7 kg)  
Receiver Electronics Module: 7.8 lbs (3.6 kg)

Corporation, or if the system is used in a manner not conforming to its intended use.

#### CERTIFICATION—



For complete approval details, refer to the appropriate Appendix:

- Appendix A - FM
- Appendix B - CSA
- Appendix C - ATEX
- Appendix D - IECEx
- Appendix E - Additional Approvals

#### IMPORTANT SAFETY NOTES

##### CAUTION

The wiring procedures in this manual are intended to ensure proper functioning of the system under normal conditions. However, because of the many variations in wiring codes and regulations, total compliance to these ordinances cannot be guaranteed. Be certain that all wiring complies with the NEC as well as all local ordinances. If in doubt, consult the authority having jurisdiction before wiring the system. Installation must be done by a properly trained person.

##### CAUTION

This product has been tested and approved for use in hazardous areas. However, it must be properly installed and used only under the conditions specified within this manual and the specific approval certificates. Any device modification, improper installation, or use in a faulty or incomplete configuration will render warranty and product certifications invalid.

##### CAUTION

The system contains no user serviceable internal components. Service or repair should never be attempted by the user. Device repair should be performed only by the manufacturer or trained service personnel.

##### LIABILITIES

The manufacturer's warranty for this product is void, and all liability for proper function of the system is irrevocably transferred to the owner or operator in the event that printed circuit boards are removed or the device is serviced or repaired by personnel not employed or authorized by Detector Electronics

##### CAUTION

Observe precautions for handling electrostatic sensitive devices.

##### NOTE

The LS2000 is intended for detection of hydrocarbon vapors only. The device will not detect hydrogen gas.

##### NOTE

The terminal compartment for LS2000 without relays is designed for either an increased safety "e" termination or a flameproof "d" termination of the supply cable. If a flameproof connection is chosen, then an ATEX certified cable entry device must be used. The LS2000 with relays requires Ex d cable entry devices only.

# INSTALLATION

## IDENTIFICATION OF VAPOR(S) TO BE DETECTED

It is necessary to identify the flammable vapor(s) of interest at the job site in order to determine the proper calibration gas setting for the LS2000. In addition, the physical and fire hazard properties of the vapor, such as vapor density and flashpoint, should be identified and used to assist in selecting the optimum detector mounting locations within the area. The detector must be installed by qualified personnel only, following local electrical equipment installation practices.

## SYSTEM LOCATION CONSIDERATIONS

The LS2000 system is designed for installation in hazardous industrial areas. Each module is normally installed using a solid vertical steel post or flat surface mounting adapter to support the weight of the module. The modules must be strategically located so that the hydrocarbon vapor(s) to be detected will intersect the light beam generated by the transmitter module. Dispersion characteristics and behavior of the vapor cloud resulting from a gas leak can be difficult to estimate due to the significant number of variables that exist at different applications. Identification of expected gas leakage source(s), leak scenario identification, determination of prevailing wind direction, and onsite leak simulation are the steps generally recommended to provide the most accurate means of identifying optimum system installation locations.

In all cases, the beam path and surrounding area should be kept free of obstructions that could block the infrared beam or hinder the free movement of air within the area. A clear beam path of 20 CM diameter or greater is required. The system is immune to the effects of exposure to both direct and reflected sunlight. Refer to Figures 7.1 and 7.2 for a representation of the exclusion zone.

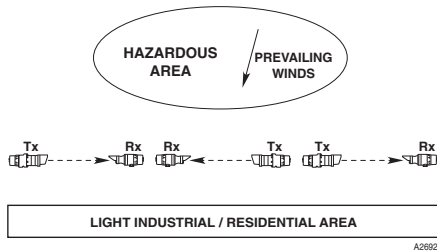

Figure 6—Proper Order of Modules for a Multiple System Installation

Avoid installation in areas with obstructions such as steam vents and plumes, smoke stacks and chimneys, walkways and personnel areas, splash and sprayed water, parking, loading, cranes, vehicle-related areas such as bus stops, road junctions, and vegetation such as trees, shrubs, grass, etc.

Det-Tronics Field Service Engineering group routinely provides jobsite application surveys and analysis for customers, and their services are highly recommended if guidance on optimum installation locations is required. Additional guidance on the positioning of gas detectors for optimum coverage is contained in BS6959 and other national codes. Consult these codes of practice when determining where detectors are to be located.

Consideration of the following system location guidelines is also recommended. Routine maintenance is recommended after abnormal events.

### Module Separation Distance

The transmitter and receiver modules must be installed directly facing each other across the area to be protected. Physical obstructions in the direct line of sight between the modules are not permitted. The overall line of sight distance between the modules must not fall outside the specified operating distance range (refer to the "Specifications" section of this manual for details).

### Multiple System Installations

If multiple LS2000 systems are to be installed, ensure that each receiver can view only the intended transmitter. For fence line applications, the recommended order is Tx-Rx, Rx-Tx, Tx-Rx, etc. as shown in Figure 6.

For redundant systems, spacing between units should be a minimum of 3.3 ft (1 meter) and the receiver should be set back from the transmitter a minimum of 12 inches (30 cm) as shown in Figure 7.

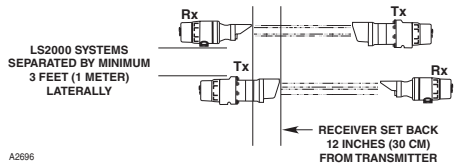

Figure 7—LS2000 Systems in Redundant Configuration

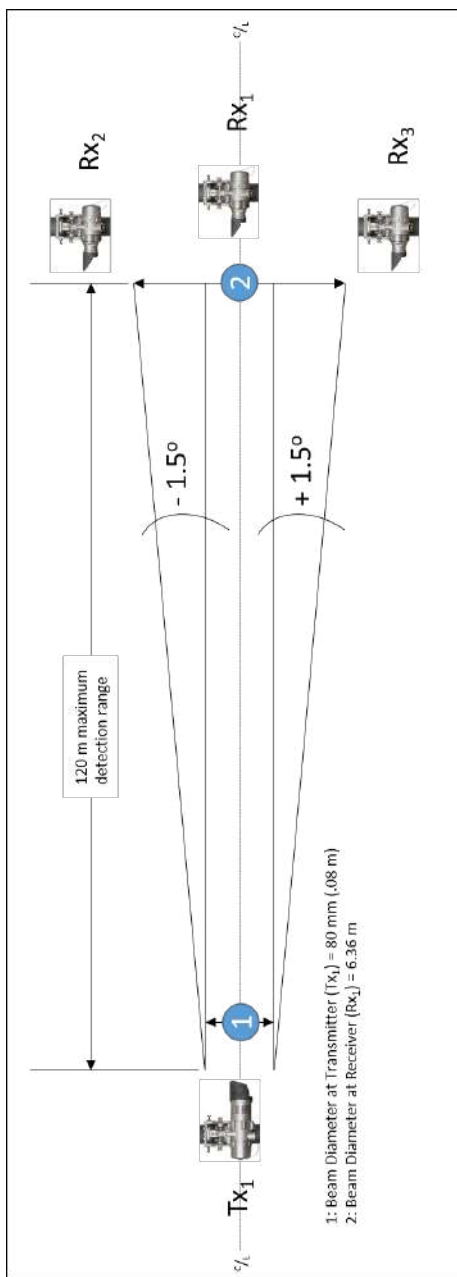

Figure 7.1: Geometric illustration of the exclusion envelope based on optical irradiance pattern

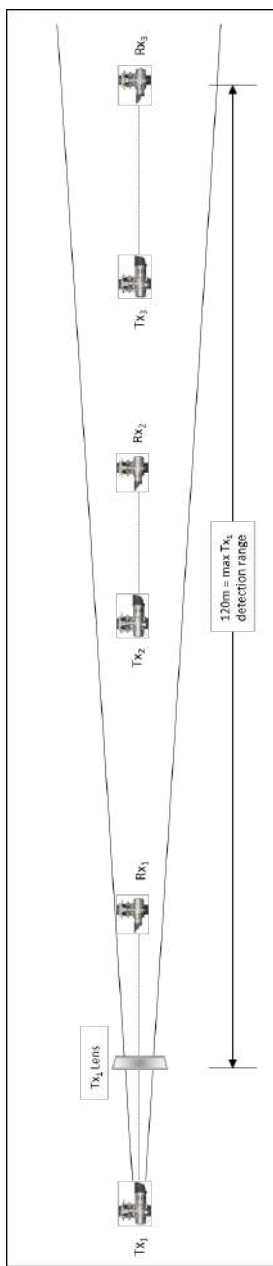

Figure 7.2: Illustration of LS2000 linear detector arrangement that can be subject to cross talk

## System Mounting Elevation

In all cases, the modules should be installed at the same elevation above grade to ensure that alignment capability and foul weather performance are not compromised. For detection of lighter than air vapors such as methane, installation of modules at approximately 2 meters above grade minimizes typical beam block conditions due to human activities, while enabling satisfactory detection capability. For detection of heavier than air vapors, installation of detectors below the expected leakage source is generally recommended unless nuisance beam blocks will occur at an unacceptable rate. In this case, identification and analysis of application specific conditions should be completed to determine the optimum installation elevation.

### NOTE

Consideration should be given during design to accessing the detector to facilitate maintenance functions such as alignment and cleaning during the life time of the detector.

## Sources of Heavy Contamination

Avoid locations where high levels of contaminants will persistently be blown onto the detector windows. Potential sources of heavy contamination include generator / turbine exhausts, flare stacks, drilling equipment, process vents / chimneys, etc. If sources of heavy contamination cannot be avoided, consider fitting extra shielding and/or providing good access for routine cleaning.

## LED Visibility

Whenever possible, select a mounting orientation where the status indication LED is visible to personnel within the area.

The LS2000 provides the option to turn off the Green LED in the Normal mode when no alarms or faults are occurring. When configured for OFF mode, the green LED will turn OFF after a specified period of time. The default is 60 seconds, with a selectable range from 30 to 600 seconds.

Do NOT expect the LED to turn off immediately after changing the setting. Also note that momentary closure of the magnetic switch, fault clear, and alarm clear will reset the OFF mode timer, and the green LED will remain lit for the selected time delay period.

This option is selected from the "Gen Configuration" screen using HART communication.

## Snow and Ice in Ambients Below -20°C

The heated optics on both modules will melt snow

or ice on the windows in ambient temperatures down to approximately -20°C. Below this temperature, snow or ice blown onto the window will not be melted until the ambient temperature rises. If long term outdoor operation in very cold climates is intended, extra shielding / covers are recommended to prevent accumulation of snow and ice on the windows.

## Deluge and Flooding

The modules are rated IP66/IP67 and will not be damaged by occasional deluge or flooding. However, during such an event, the unit will completely lose its IR signal and will enter the "Beam-Block / Fault" state. In addition, when the deluge / flooding subsides, there is the possibility that contaminants will be left on the windows. Install the modules away from areas prone to deluge or flooding.

## Areas Prone to Subsidence and Settling

Avoid installation of the modules in areas where problems with subsidence, settling or thawing of permafrost can occur or cause significant movement. If such locations cannot be avoided, the foundations of the mounting structure should be engineered to minimize any angular movements between the receiver and transmitter."

## Areas Prone to Earthquakes

In the event of an earthquake, there is a chance that the modules will become misaligned with respect to each other. As long as the modules do not suffer from direct mechanical impact damage during an earthquake, they should remain undamaged by such events. After an earthquake, it is recommended that the system alignment be checked. Anti-vibration mounts are unlikely to be of any benefit and are not recommended.

## Misalignment by Accidental Impact

Locations where there is a significant likelihood of equipment, personnel or moving objects accidentally knocking the modules out of alignment should be avoided where possible. If such locations cannot be avoided, measures including improved mechanical protection and warning notices should be considered.

## MODULE MOUNTING RECOMMENDATIONS

LS2000 modules must be affixed to a solid structure capable of supporting a minimum of 100 lbs. (46 kg) located within the system's rated separation distance. The vibration in the structure should not exceed the specifications in the following standards:

- FM6325
- UL/FM 60079-29-4 (previously ANSI/ISA 12.13.04)
- EN/IEC 60079-29-4
- Class Guideline DNVGL-CG-0339

A building wall, a heavy steel I-beam, or nearly any type of masonry typically provides the most rigid mounting surface available. However, avoid the use of wood structures or supports if the possibility of warping exists.

When using a vertical post a square stock pole is recommended.

The post can be set into the ground or attached to a secure surface. If a post is set into the ground, the portion below grade should be set in concrete at least 1 meter deep.

#### IMPORTANT

In all cases, consider whether additional bracing or support is needed to ensure the structural integrity of the module installation. See Figure 8. Accurate module alignment is essential for proper performance of a line-of-sight gas detection system. Movement may have a detrimental effect on alignment.

Module mounting options include:

- A vertical or horizontal post with a nominal outside diameter of 4.5", 11.43 cm. Acceptable outside diameter range is 4–4 5/8", 10.16–11.75 cm. See Figure 9.
- For flat surface mounting, refer to Figure 10.

#### NOTE

Anti-seize material (provided) must be applied to the U-bolt threads at the time of installation to prevent galling.

#### NOTE

To ease installation and future removal, all threaded covers, stopping plugs, and thread adapters must be installed using thread lubricant. See the "Ordering Information" section for part number — avoid the use of silicone grease. For devices with NPT threads, Teflon tape or thread seal lubricant must be used for enhanced sealing. A minimum torque of 20 foot-pounds is required to maintain ingress protection. To maintain the IP or NEMA ratings when using NPT stopping plugs, one to three wraps of Teflon tape is required.

Mounting bolts should be secured with either a lock washer or locking nut.

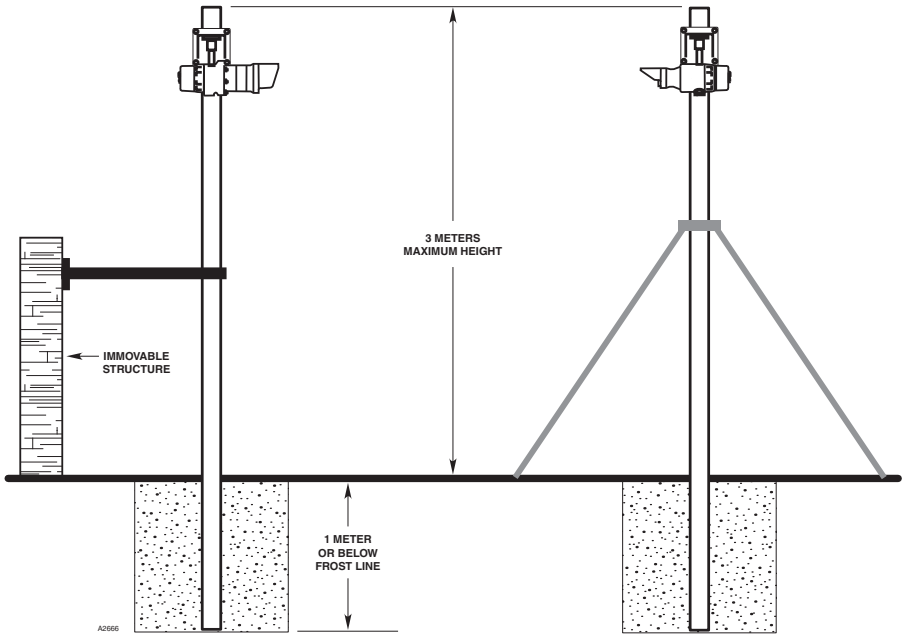

**NOTE: INSTALLATIONS NEAR MAXIMUM HEIGHT TYPICALLY REQUIRE BRACING TO ENSURE NO MOVEMENT OF THE LS2000 DETECTOR.**

Figure 8—Example of Bracing Added to Vertical Mounting Poles for Increased Robustness of LS2000 Installation



Figure 9—LS2000 Gas Detector Mounted to Vertical Post



Figure 10—LS2000 Gas Detector Mounted to Flat Surface (Refer to "Dimensions" in the "Specifications" section for mounting plate hole spacing dimensions.)

## REPLACING AN EXISTING MODEL OPECL WITH AN LS2000

### Flat Surface Mount

An optional adapter plate (part number 012718-003) is available for converting an existing OPECL flat surface mount to an LS2000 flat surface mount without drilling new holes. See Figure 11 for dimensions. The mounted LS2000 will have the following offsets compared to the OPECL detector (when looking straight at the wall/beam).

Left/right = 0"

Up/down = 1 inch lower

In/out = 0.3" closer to the wall/beam for the LS2000.

### Pole Mount

The LS2000 can be mounted to the same pole as the Model OPECL using U-bolts. The LS2000 will have the following offsets compared to the OPECL detector.

Left/right = 0"

Up/down = 0" if the top U-bolt for the LS2000 is mounted 1" lower than the top U-bolt of the OPECL detector.

In/out = 0.8" closer to the pole for the LS2000.

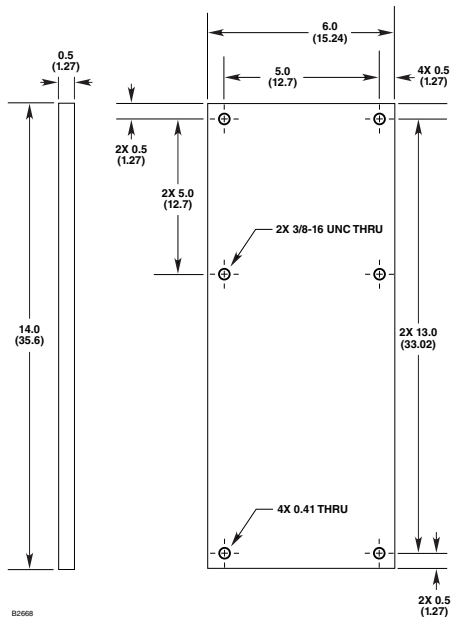

Figure 11—Dimensions of 012718-003 Flat Surface Mounting Plate in Inches (cm)

## 24 VDC POWER SUPPLY REQUIREMENTS

Calculate the total gas detection system power consumption rate in watts from cold start-up. Select a power supply with adequate capability for the calculated load. Ensure that the selected power supply provides regulated and filtered 24 Vdc power for the entire system. If a back-up power system is required, a float-type battery charging system is recommended. If an existing source of 24 Vdc power is being utilized, verify that system requirements are met.

### NOTE

If disconnection of power is required, separate disconnect capability must be provided.

## WIRING CABLE REQUIREMENTS

Always use proper cabling type and diameter for input power as well as output signal wiring. 14–18 AWG, 2.5–1.0 mm<sup>2</sup> shielded stranded copper wire is recommended.

Always install a properly sized master power fuse or breaker on the system power circuit.

### NOTE

The use of shielded cable in conduit or shielded armored cable is required for ATEX conformance. In applications where the wiring is installed in conduit, dedicated conduit is recommended. Avoid low frequency, high voltage, and non-signaling conductors to prevent nuisance EMI problems.

### ⚠ CAUTION

The use of proper conduit installation techniques, breathers, glands, and seals is required to prevent water ingress and/or maintain the explosion-proof rating.

### ⚠ WARNING

It is required that each conduit plug or fitting be wrench tightened to an appropriate installation torque and meet the minimum thread engagement requirements per the applicable local standards, codes and practices in order to retain the defined ingress protection rating. All unused entries must contain appropriately rated conduit plugs or fittings. PTFE sealant (or equivalent) should be used on NPT threads.

## POWER WIRING SIZE AND MAXIMUM LENGTH

1. To ensure proper operation, LS2000 power terminals and 4-20 mA terminals must receive 18 Vdc minimum. 24 Vdc is recommended.
2. Always determine voltage drops that will occur to ensure that 24 Vdc is delivered to the LS2000.
3. Normally, nothing smaller than 18 AWG, 1.0 mm<sup>2</sup> is recommended by Det-Tronics for LS2000 power cabling.

Wire size requirements are dependent upon power supply voltage and wire length.

The maximum distance between the LS2000 detector and its power supply is determined by the maximum allowable voltage drop for the power wiring loop. If the voltage drop is exceeded, the device will not operate. To determine the maximum power loop voltage drop, subtract the minimum operating voltage for the device (18 Vdc) from the minimum output voltage of the power supply.

To determine the actual maximum wire length:

1. Divide the maximum allowable voltage drop by the maximum current draw of the LS2000 (0.771 A),
2. Divide by the resistance of the wire (ohms/foot value available in wire manufacturer's specification data sheet),
3. Divide by 2.

For example: Consider an installation using 18 AWG wiring with a power supply providing 24 Vdc.

Power supply voltage = 24 Vdc,  
LS2000 minimum operating voltage = 18 Vdc

$$24 - 18 = 6 \text{ Vdc}$$

Maximum Voltage Drop = 6  
Maximum Current = 0.771 A  
Wire Resistance in Ohms/Foot = 0.006523

$$6 \div 0.771 \div 0.006523 \div 2 = 596 \text{ feet}$$

## OPTIONAL RELAYS

Optional relay contacts are "dry," meaning that the installer must provide the voltage to the common terminal of the relay output.

AC voltage should not be switched directly using the LS2000 relays. The use of an external relay is required if AC voltage must be switched by the LS2000 relays. Note: External relay is not covered by any Certifications.

In order to change alarm relay settings from the factory default settings, it is recommended to use a HART Field Communicator. Contact the factory for further assistance.

### NOTE

Refer to "Alarm Relays" in the "Specifications" section of this manual for important information regarding alarm relays.

## WIRING PROCEDURE

For systems using conduit, modules must be wired using a short piece of suitable flexible conduit to allow optical alignment of the modules. Conductor insulation should be stripped off with a bare conductor length of 0.2 inch (5 mm) minimum and 0.35 inch (9 mm) maximum. Screw terminal torque range is 3.5–4.4 lb.-in. (0.4–0.5 N·m).

Cable shield, if used, should be properly terminated. If not terminated, clip the shield wire off short and insulate it within the detector housing to prevent the shield wire from accidentally contacting the detector housing or any other wire.

Figure 12 shows the wiring terminal strip located inside the detector's integral junction box.

### NOTE

The LS2000 housing must be electrically connected to earth ground. A dedicated earth ground lug is provided for this purpose.

Figure 13 shows the wiring terminal configuration for the LS2000 transmitter.

Figure 14 shows the wiring terminal configuration for the LS2000 receiver without relays.

Figure 15 shows the wiring terminal configuration for the LS2000 receiver with relays.

Figures 16 through 19 show the 4-20 mA output of the LS2000 receiver in various wiring schemes.

See Figure 20 for benchtop test wiring.



**NOTE**

For proper HART communication, it is required that an analog signal loop resistance of 250 to 500 ohms be present at the receiver analog output terminals. For LS2000 systems using HART communication, the maximum wiring distance is 2,000 feet. No external resistance needs to be added to the transmitter wiring for proper HART operation.

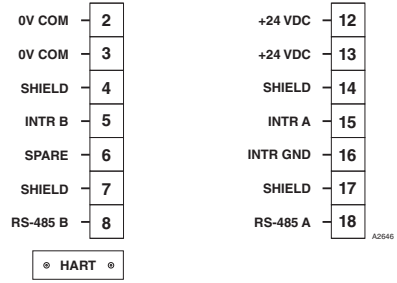

Figure 13—Transmitter Wiring Terminal Identification

A pair of HART connector pins is provided for ease in connecting a HART handheld device. See Figure 24 for location.

**NOTE**

To establish the optional “communication link” between the transmitter and receiver, connect a three-wire shielded cable to the INTR A, INTR B, and INTR GND terminals of the two devices. See Figure 21. Take care not to connect any of these lines to 0V COM. Doing so will damage the 4–20 mA circuit.

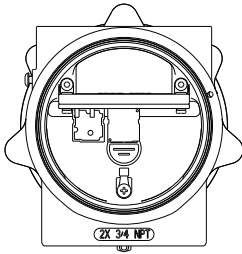

Figure 12—Terminal Strip Located Inside Wiring Compartment

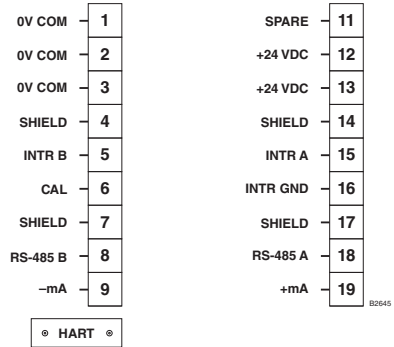

Figure 14—Wiring Terminal Identification for LS2000 Receiver without Relays

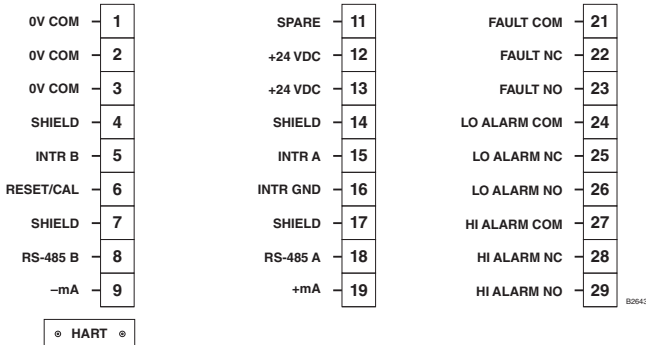
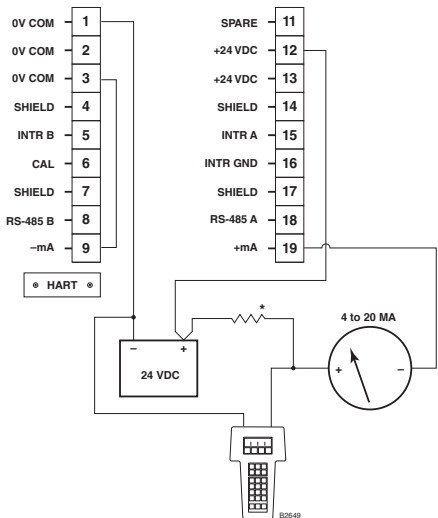
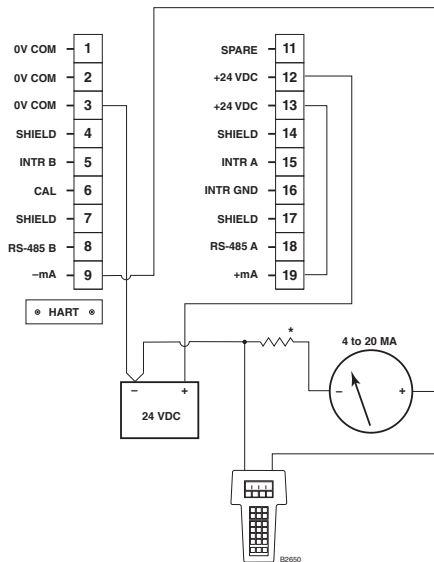

Figure 15—Wiring Terminal Identification for LS2000 Receiver with Relays



\*TOTAL LOOP RESISTANCE = 250 OHMS MINIMUM, 600 OHMS MAXIMUM.  
NOTE: SHIELDED CABLE RECOMMENDED (REQUIRED FOR ATEX).

Figure 16—Receiver Wired for Non-Isolated 4-20 mA Current Output (Sinking)



\*TOTAL LOOP RESISTANCE = 250 OHMS MINIMUM, 600 OHMS MAXIMUM.  
NOTE: SHIELDED CABLE RECOMMENDED (REQUIRED FOR ATEX).

Figure 18—Receiver Wired for Non-Isolated 4-20 mA Current Output (Sourcing)

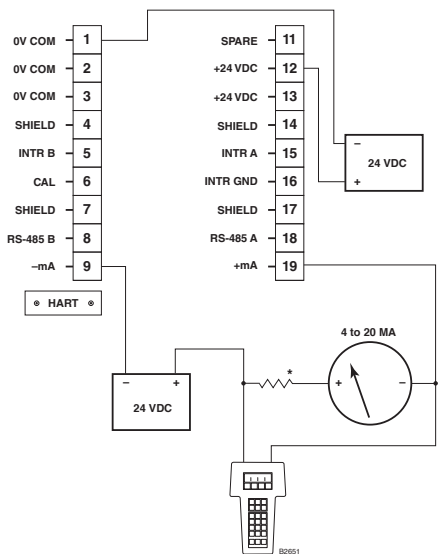

\*TOTAL LOOP RESISTANCE = 250 OHMS MINIMUM, 600 OHMS MAXIMUM.  
NOTE: SHIELDED CABLE RECOMMENDED (REQUIRED FOR ATEX).

Figure 17—Receiver Wired for Isolated 4-20 mA Current Output (Sinking)

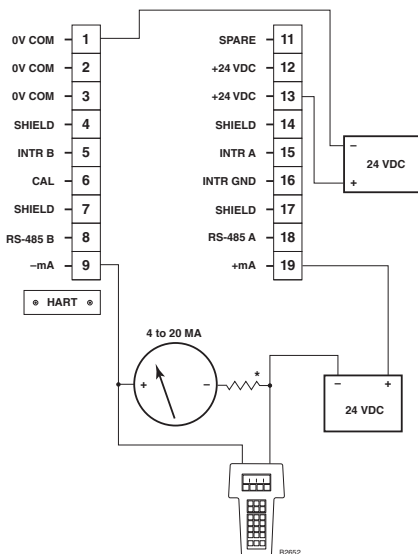

\*TOTAL LOOP RESISTANCE = 250 OHMS MINIMUM, 600 OHMS MAXIMUM.  
NOTE: SHIELDED CABLE RECOMMENDED (REQUIRED FOR ATEX).

Figure 19—Receiver Wired for Isolated 4-20 mA Current Output (Sourcing)

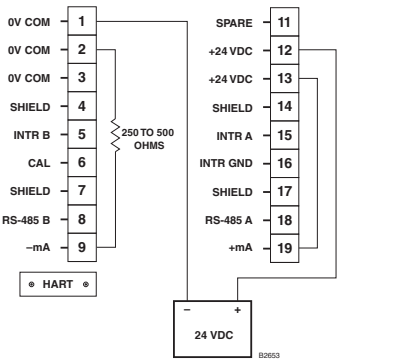

NOTE: THE HART HANDHELD DEVICE CAN BE CONNECTED EITHER TO THE HART TERMINALS OR ACROSS THE LOAD RESISTOR.

Figure 20—Wiring the LS2000 Receiver for Benchtop Testing/Programming Using HART Protocol

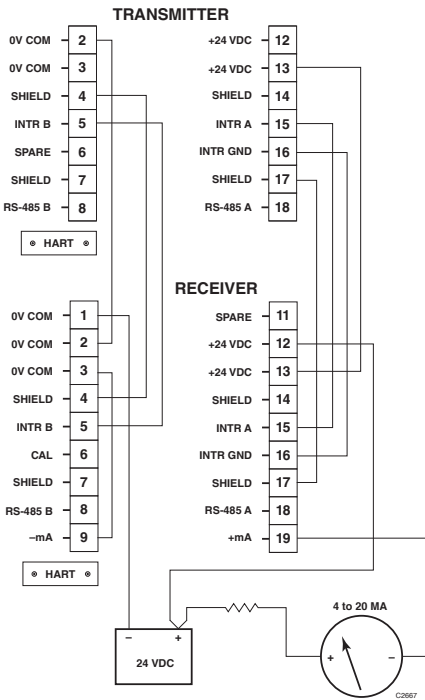

NOTE 1: TOTAL LOOP RESISTANCE OF 4-20 MA CIRCUIT = 250 OHMS MINIMUM, 600 OHMS MAXIMUM.  
 NOTE 2: NOTE: SHIELDED CABLE RECOMMENDED (REQUIRED FOR ATEX).  
 CAUTION: DO NOT CONNECT THE COMMUNICATION LINK "INTR GND" TERMINAL TO POWER SUPPLY COMMON OR ANY OTHER GROUND CONNECTION.

Figure 21—Typical System Wiring Including Optional Communication Link — Receiver Wired for Non-Isolated 4-20 mA Current Output (Sinking)

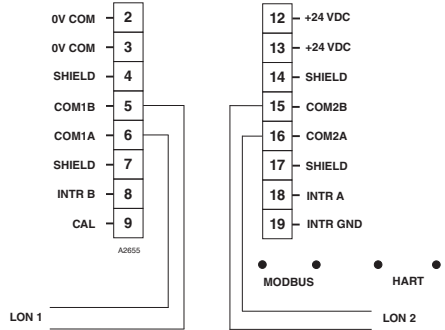

Figure 22—LS2000 LON Wires

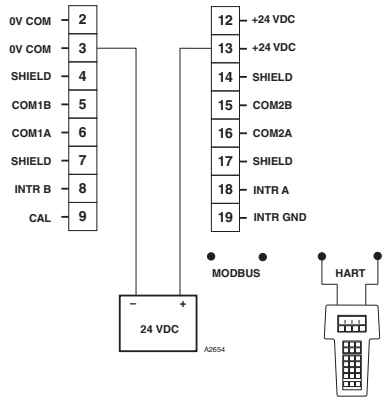

Figure 23—LS2000 LON Power and HART

## STARTUP

When the LS2000 is installed and wired as described in the "Installation" section, it is ready for commissioning. If the application requires that specific changes be made to the factory settings, HART communication will be required.

### NOTE

Ensure that alarm devices are bypassed during commissioning.

### NOTE

The safety function (gas input-to-actuation/notification) must always be verified upon completion of installation and/or modification.

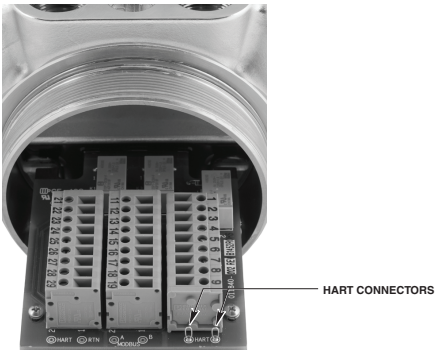

Figure 24—Location of HART Connector Pins (Receiver Module Shown)

## ALIGNMENT

### OVERVIEW

The LS2000 modules must be properly aligned before normal operation will be attained.

### NOTE

Refer to the FM, ATEX, or IECEx Appendix for information regarding the effect of misalignment on system accuracy.

### IMPORTANT

Upon completion of system alignment, ensure that ALL bolts on the LS2000 mounting and alignment bracket are properly tightened. Mounting bolts shall be secured with either lock washers or locking nuts.

### EQUIPMENT REQUIRED

1. Properly installed and powered LS2000 system (transmitter and receiver). Easy access to both modules is highly recommended.
2. LS2000 Alignment Tool. The alignment tool is recommended for use in commissioning all LS2000 systems. The following instructions cover the use of the Alignment Tool.
3. 9/16 inch wrench.
4. 15/16 inch wrench.
5. For installations with short separation distances (5-15 meters for the short range model and 30-40 meters for the long range

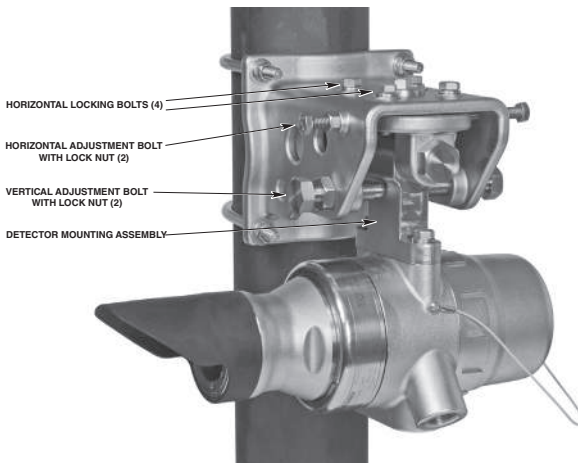

Figure 25—LS2000 Mounting and Alignment Bracket (Receiver Module Shown)

model), the short range aperture kit (supplied) is typically needed. Refer to the "Aperture Kit for Short Range Applications" section in this manual for details.

#### ALIGNMENT PROCEDURE

1. Ensure that the system modules are located within the specified separation range and securely fixed to the support structures. Bypass all external gas alarm devices that are connected to the receiver outputs.
2. Ensure that the system modules are installed with their windows at approximately the same height above grade. Each module should be roughly aligned to face in the direction of the other module.
3. Loosen the Horizontal and Vertical Adjustment Bolts on the mounting and alignment bracket using the 9/16" wrench for the Horizontal Adjustment Bolts and the 15/16" wrench for the Vertical Adjustment Bolts. See Figure 25.
4. Loosen the four Horizontal Locking Bolts on top of the mounting and alignment bracket using a 9/16" wrench, then re-tighten until just snug against the top plate of the Detector Mounting Assembly. The Detector Mounting Assembly should still be able to rotate on its axis when adjusting the Horizontal Adjustment Bolts. If not, slightly loosen the four Horizontal Locking Bolts.
5. Remove the brow by gently working side to side while pulling forward.
6. Attach the Alignment Tool onto the receiver module by inserting the captive thumbscrews into the threaded holes on the faceplate. See Figure 26. Ensure that the alignment tool is properly attached, that the eyepiece is accessible, and that the thumbscrews are completely tightened.
7. Using the Horizontal and Vertical Adjustment Bolts, adjust the receiver module as required until the cross hairs are centered as close as possible to dead center on the window of the transmitter module. Do not tighten the adjustment bolts at this time, just snug down all adjustment bolts finger tight.
8. Slightly loosen the Vertical Adjustment Bolts so that tightening the four Horizontal Locking Bolts does not cause the Detector Mounting Assembly to bind as it is being pulled up.
9. Tighten the four Horizontal Locking Bolts in an opposing-alternating pattern. Torque each bolt to 200 in-lbs (22.6 N·m) maximum.



Figure 26— LS2000 with Alignment Tool Installed

10. Tighten the Horizontal Adjustment Bolts to 200 in-lbs (22.6 N·m) maximum, being careful to tighten each bolt evenly against each other to prevent torquing of the Detector Mounting Assembly. Tighten the Locking nuts to 200 in-lbs (22.6 N·m) maximum. The mounting and alignment bracket is now secured horizontally.
11. Verify alignment using the Alignment Tool. The Vertical alignment may have shifted slightly due to tightening of the four Horizontal locking bolts pulling the Detector Mounting Assembly up. Adjust the vertical alignment if needed using the Vertical Adjustment Bolts.
12. When proper alignment has been achieved, tighten the Vertical Adjustment Bolts and Locking Nuts to 90 ft-lbs (122 N·m) maximum, being careful to tighten each bolt evenly against each other to prevent torquing of the Detector Mounting Assembly. The Receiver is now secured vertically and aligned with the Transmitter.
13. Rotate the telescope alignment tool by 180° and verify that the cross hairs are in the same position. If the cross hairs are not in the same position, the telescope alignment screws must be adjusted as follows:
  - A. Adjust the telescope alignment screws until the cross hairs are midway between the original position (center of transmitter window) and the current position (after the scope was rotated 180°). See Figure 27.
  - B. Return the scope to its original position (rotate 180°) and repeat steps 7 through 13 until correct alignment is achieved.

STEP 1: CENTER CROSS HAIRS ON TARGET USING ADJUSTMENT BOLTS ON MOUNTING PLATE (POSITION A).

STEP 2: ROTATE SCOPE 180°. ALIGNMENT ERROR CAUSES CROSS HAIRS TO MOVE TO POSITION B.

STEP 3: ADJUST ALIGNMENT SCREWS ON SCOPE TO PLACE CROSS HAIRS AT POSITION C.

STEP 4: ROTATE SCOPE 180° TO ORIGINAL POSITION.

STEP 5: REPEAT STEPS 1 TO 4 UNTIL THE UNIT IS CORRECTLY ALIGNED.

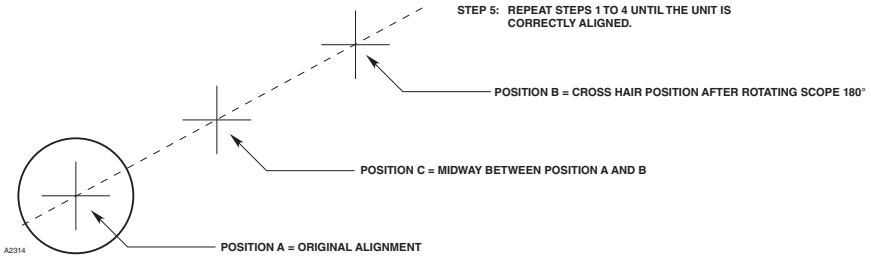

Figure 27—LS2000 Alignment Using the Telescope Alignment Tool

#### NOTE

No further adjustments are required when the cross hairs are centered on the window with the scope in both 180° positions.

14. Repeat the alignment procedure for the transmitter module (steps 3 to 13).
15. Re-check the alignment one final time using the alignment tool and adjust as needed.
16. Remove the Alignment Tool and re-install the brow.
17. Bypass all external gas alarm devices that are connected to the receiver outputs, and then apply 24 Vdc power to the modules.
18. Upon completion of warm-up mode (approximately two minutes or less), the receiver should produce a 4 mA output signal and a green LED indication. If not, the required zero calibration step below may resolve this issue.
19. For installations with module separation distances between 5 and 40 meters, install the aperture as described in the "Aperture Kit for Short Range Applications" section.
20. Perform a zero calibration. (Refer to "Zero Calibration" in the "Calibration" section of this manual.) Any faults that may be present as a result of the alignment process should be cleared.

#### NOTE

The LS2000 transmitter lamp output intensity is automatically optimized during the zero calibration process if the communication link wires are attached between transmitter and

receiver. If no communication link is installed, the transmitter lamp output can be adjusted via Modbus or HART connection to the transmitter. This adjustment is rarely needed. (See "Transmitter Lamp Voltage" section for more information.)

21. Proper operation should be confirmed by bypassing all system alarms, then placing an optical test film (sold separately) into the light beam and checking for the appropriate 4–20 mA output level or relay actuation. The LS2000 test film packet consists of five separate test films.  
  
Table 7 shows the response of the different LS2000 gas settings to each of the five test films for ISO and IEC calibration gas concentrations. Products with "A" and "B" type approvals are factory calibrated to ISO gas concentrations. Products with "E" approval are factory calibrated to IEC gas concentrations. Alarm conditions, if present, should clear when the test film is removed from the beam. See LS2000 Model Matrix (Pg. 36) for Type approvals.
22. Confirm proper operation by completely blocking the light beam with a solid object such as a piece of cardboard until a beam block fault is signaled by the appropriate 4-20 mA output level or relay action (default delay is 60 seconds). The fault should clear when the blocking device is removed from the beam.
23. When Basic Alignment and Zero Calibration have been successfully completed, a green LED should be displayed on the receiver module and the analog signal output level should be 4.0 milliamperes.

Table 7—Typical System Response in LFL-M (% Full Scale) Using Gas Test Films

Number of Test Films	Methane		Propane		Butane	
	Calibration Gas Concentration					
	ISO	IEC	ISO	IEC	ISO	IEC
1	0.6 (13%)	0.7 (15%)	1.2 (25%)	1.4 (28%)	1.1 (23%)	1.4 (28%)
2	1.5 (29%)	1.7 (34%)	2.6 (51%)	3.0 (60%)	2.3 (47%)	3.0 (60%)
3	2.5 (50%)	3.0 (60%)	3.9 (79%)	4.7 (94%)	3.6 (72%)	4.7 (94%)
4	3.7 (74%)	4.6 (91%)	5.4 (108%)	6.0 (120%)	4.9 (98%)	6.0 (120%)
5	5.0 (100%)	5.9 (119%)	6.0 (120%)	6.0 (120%)	6.0 (120%)	6.0 (120%)

Notes:

- 1 A HART handheld device is needed to read over-range values
- 2 Accuracy of Test Films = +/- 15% LFL-M

### APERTURE KIT FOR SHORT RANGE APPLICATIONS

The Short Range Aperture Kit enables successful application of the LS2000 gas detector at short separation distances (5–15 meters for the short range model and 30–40 meters for the long range model). The aperture is made of aluminum and is included with the LS2000 transmitter.

#### Procedure for System Commissioning Using the Aperture

1. Align the LS2000 system using the Basic Alignment procedure. At the completion of this alignment, the output signal at the receiver may indicate a fault condition as a result of signal saturation. (See the “Gain Level Check” section for additional information on signal strength checks.)
2. Attach the aperture to the front of the LS2000 transmitter module using the captive screws provided. For best weather protection, the aperture hole should be located at the top of the unit.
3. Perform a zero calibration. After performing the zero calibration, the receiver module should display a normal condition (green LED) and a steady 4 mA output.

#### NOTE

If the receiver continues to indicate a fault condition as a result of signal saturation, rotate the aperture 90 degrees and repeat step 3 above.

### RECOMMENDATIONS FOR USING THE HART FIELD COMMUNICATOR

#### WARNING

The LS2000 does not use Intrinsically Safe circuitry for connection to the HART Communicator. Connecting a HART Communicator to the LS2000 may invalidate the Intrinsic Safety circuits of the HART Communicator.

#### WARNING

Declassify the area before removing the LS2000 module's terminal cover.

- The HART communication device must include the LS2000 device descriptor (DD) software menu. The use of HART communication devices without the proper DDs may establish generic mode HART communication, but will not enable proper operation with LS2000. Refer to the HART Appendix for additional information.
- A minimum level of understanding with regard to the operation and navigation of the HART communicator is required. Please refer to the appropriate HART communicator instruction manual for basic operating instructions if required. Additional information on the use of the HART communicator is provided within the HART Appendix in this document.
- For proper HART communication to occur, it is required that a 250-500 ohm resistive load be present in the LS2000 analog 4–20 mA signal loop output. See “Wiring Procedure” in the “Installation” section.

## GAIN LEVEL CHECK (Optional)

It is necessary to complete the alignment procedure before checking the gain level. HART or Modbus communication is required to check the gain.

### Procedure

1. Connect the handheld HART communicator to the receiver module's 4–20 mA circuit.
2. Turn on the HART communicator and check for LS2000 device recognition. When HART communication is established, the LS2000 Online menu will be displayed on the communicator display.
3. From the Online menu, Navigate to the Detector Setup menu, then select the Sensor Setup menu.
4. The following screen will be displayed. Observe the level indicated for "Gain."

Sensor Setup	
1) Processing mode	xxxx
2) Interconnect mode	xxxx
3) Log interim beam block	Y/N
4) Gain Mode	xxxx
5) Gain	xx
6) Tx lamp voltage	xxxx
7) Auto voltage during cal	E/D
8) Beam block fault time	xxx

← Gas Gain number

5. Table 8 can be used as a guideline for new installations to assess the detector gain level with proper alignment.

Table 8—Expected Gas Gain Settings for LS2000

Distance (meters)	Transmitter Type	
	Short Range	Long Range
5	1 (Aperture)	
20	5 (Aperture)	
30	1	2 (Aperture)
40	2-5	5 (Aperture)
60	5-10	1-2
80		2-5
100		2-5
120		5-10

6. Verify the gain setting. The gas gain setting options are 1, 2, 5, 10, 20, 50, and 100; ideal gain settings are 2, 5, and 10.

A gain of 1 indicates that the system may be near saturation (signal strength is too high). If the gas gain number = 1 and the Active avg or Ref avg numbers are greater than 1500, use the aperture kit to reduce signal. See the "Transmitter Lamp Voltage" section for additional signal strength reduction options as needed. If using the Long range receiver, it may be necessary to switch to the Short range version.

A gain of 20 or greater indicates that the system signal strength is less than expected. Ensure that the system has a clear beam path, clean windows, and was properly aligned and calibrated in clear weather. See the "Transmitter Lamp Voltage" section for additional signal strength increase options as needed. If using the Short range receiver, it may be necessary to switch to the Long range version.

Contact the factory for further information or assistance.

In all cases, a green LED and 4 mA output indicate that the unit will properly perform its safety function. Gain adjustments and checks are simply a way to optimize the system so that it will perform in the widest variety of application scenarios (e.g., shifting mounts, inclement weather, mechanical impact, lens obscuration, etc.).

## TRANSMITTER LAMP VOLTAGE

The LS2000 has a feature that automatically adjusts transmitter lamp voltage during zero calibration if the communication link is connected. (This feature is disabled by default.) Alternatively, lamp voltage can be adjusted via HART or Modbus communication directly to the transmitter. The transmitter lamp voltage should be lowered to reduce signal at the receiver. Transmitter lamp voltage should be raised to increase signal at the Receiver. The adjustment range for the transmitter lamp is 400–950 V (default = 750 V). Contact the factory for further information or assistance.

### WARNING

Changing HART parameters is not recommended unless advised by the factory to do so.



# CALIBRATION

## CALIBRATION OVERVIEW

Span calibration is not required. The LS2000 supports non-intrusive field zero calibration, although routine calibration is normally not required. See Table 1 for factory span calibration concentrations based upon variant type.

## ZERO CALIBRATION

Zero Calibration is a one-step process consisting of clean air (zero) condition adjustment only, which is performed automatically by the device. This procedure adjusts the "clean air" signal output only, and is normally used if the gas output signal level has drifted. The cause of drift is typically due to the presence of background gas during calibration. Additionally, the zero calibration procedure will optimize the transmitter lamp output intensity if the optional communication link is installed. This is useful for situations where the signal strength at the receiver is too high (saturation) or too low. Ensure that the optical path is clear of hydrocarbons prior to calibration initiation to ensure an accurate zero (clean air) condition.

## IMPORTANT CALIBRATION NOTES

### NOTE

Ensure that the detector has been operating for at least two hours before calibrating.

### NOTE

Always ensure that the LS2000 optics are totally free of all hydrocarbons before initiating calibration.

### NOTE

Zero calibration shall not be performed if the detector is improperly aligned. When correct alignment is achieved, the sensor ratio (active vs. reference signals) should be between 0.8 and 1.3. To check the ratio, connect a HART handheld and navigate to:

Main > Detector Status > Sensor Info > Ratio

An out-of-tolerance ratio value typically indicates incorrect alignment or presence of background gas.

## CALIBRATION INITIATION

Calibration may be initiated by any of the following means:

- The onboard magnetic calibration switch
- Digital communication via HART (see HART appendix), Modbus RTU, or LON communication
- Remote calibration line

Upon initiation, the LS2000 automatically performs the zero calibration adjustment, and then signals with a green LED when this operation is complete.

## Calibration Using Magnetic Switch

The LS2000 receiver provides an onboard magnetic calibration/reset switch for non-intrusive calibration capability. The magnetic switch is actuated by holding a calibration magnet at the specified location on the device bulkhead. See Figure 2 for switch location. An onboard multi-color LED provides status indication during calibration.

To initiate calibration, hold the calibration magnet against the side of the receiver at the location shown in Figure 2. Apply the magnet for 3 to 30 seconds and release while the LEDs are flashing yellow at 5 Hz.

## Calibration Using Calibration Line Terminal

The calibration / reset function can be accomplished remotely by installing a switch between the CAL and 0V COM terminals of the LS2000 receiver.

To initiate calibration, short the CAL and 0V COM terminals for 3 to 30 seconds and release while LEDs are flashing yellow at 5 Hz.

## CALIBRATION SEQUENCE

1. Initiate calibration using one of the methods listed above:
  - A. The LEDs continue to flash yellow at 5 Hz.
  - B. The current output decreases to 1 mA, 2.2 mA, or as configured by the user.
2. When zero calibration is complete:
  - A. The onboard LEDs change from flashing yellow to steady green.
  - B. Calibration is complete and the current output returns to 4 mA.

### NOTE

Calibration will time out if unsuccessful after 10 minutes.

### NOTE

To abort an in-process calibration, repeat the calibration initiation sequence (e.g., hold the magnet for three seconds or more and release). The device will revert to its previous calibration setting.

## MAINTENANCE

### WARNING

Do not open cover when an explosive gas atmosphere may be present.

### NOTE

Refer to the LS2000 Safety Manual, number 95-8727, for specific requirements and recommendations applicable to the proper installation, operation, and maintenance of all SIL-Certified LS2000 IR gas detectors.

## ROUTINE INSPECTION

The LS2000 detector should be inspected periodically to ensure that external obstructions such as plastic bags, mud, snow, or other materials do not block the path and thereby impair the performance of the device.

## OPTICS CLEANING

Cleaning of the LS2000 optical surfaces is normally required only if an optical fault is indicated.

Thoroughly douse both window surfaces using a liberal amount of isopropyl alcohol to clear away contaminant particles. Repeat the alcohol flush to remove any remaining contaminants.

### WARNING

Bypass/Inhibit: Volatile organic compounds in cleaning solutions could cause false alarms.

## FUNCTIONAL CHECKING

Functional checks should be performed as required by site conditions and local regulations. For specific approval requirements regarding functional checks, see appendices and the LS2000 safety manual.

Det-Tronics provides two functional check options for the LS2000. The test film method provides a basic functional check as described in step 20 of the basic alignment procedure.

Alternatively, the gas test cell method can be used for a more precise output verification. The gas cell is typically used to verify the factory calibration of the LS2000. The gas cell has a known optical length and has infrared transparent windows on both ends. When filled with 100% v/v gas, it contains a specific LFL-m amount of gas. When the gas cell is placed in the beam of the detector, the output will rise to a specific value.

The gas cell is not intended for routine use. It does, however, demonstrate in a very direct way the response of the detector to hydrocarbons along with the resulting control action. This is particularly useful when required by regulatory authorities. See the gas cell instruction manual, number 95-8738, for further details and use instructions.

## PROTECTIVE CAPS AND COVERS

Ensure that the wiring compartment cover is installed and fully engaged.

# REPLACING LS2000 TRANSMITTER/RECEIVER ELECTRONICS MODULE

### ⚠ WARNING

Do not open when an explosive gas atmosphere may be present.

### ⚠ CAUTION

Only Det-Tronics authorized personnel are allowed to perform this repair.

### ⚠ CAUTION

Replacement of the LS2000 transmitter or receiver module requires disassembly of the device housing. Remove power to the device before disassembly.

### ⚠ CAUTION

The LS2000 detector contains semiconductor devices that are sensitive to electrostatic discharge (ESD). Use normal precautions for handling ESD sensitive devices. Handle the device by the housing, taking care not to touch electronic components or terminals.

## MODULE REPLACEMENT PROCEDURE

Tools Required:

- 6 mm hex wrench (transmitter)
- 5/16 inch hex wrench (receiver)
- Torque wrench capable of accurately measuring 40 inch-pounds

1. Bypass system alarms as needed, then remove 24 Vdc power from the LS2000 detector.



Figure 28—LS2000 Transmitter

2. Transmitter  
Remove the seven stainless steel flange bolts using a 6 mm hex wrench. See Figure 28. Take care to properly support the module as the last flange bolt is removed.

Receiver

Using a 5/16 inch hex wrench, loosen the locking set screw. Turn the retainer ring by hand to loosen the module. See Figure 29.

3. Carefully remove the old module by extracting it straight out from the bulkhead.

4. Ensure that the O-ring is present, undamaged, and correctly seated in the groove. This O-ring is required to maintain the watertight integrity of the LS2000 housing.

5. Line up the pin on the replacement module with the hole in the bulkhead and insert the module straight into the bulkhead. See Figure 30 for the transmitter and Figure 31 for the receiver.

6. Transmitter

Insert and tighten the seven flange bolts in an opposing consecutive order in two stages — first partially tighten all seven bolts equally, and then fully tighten each bolt in an opposing order to 90 in-lbs (10.2 N•m) maximum of torque. Bolts are M8-1.25x 16M.

### ⚠ CAUTION

Flange bolts are critical to maintaining the flameproof properties of the LS2000. If replacement flange bolts are needed, DEC spare part number 012713-001 must be used in order to maintain the integrity of the enclosure. The use of any other bolts will void the Ex d certification of the LS2000.



Figure 29—LS2000 Receiver

## Receiver

Fully tighten the retainer ring on the receiver module, then tighten the set screw to prevent the ring from being turned.

- When all equipment has been properly installed, ensure that system alarms are appropriately bypassed and apply power to the system.
- Perform the alignment procedure as previously described in this manual.

### IMPORTANT

If the LS2000 module had an aperture installed, install the aperture after performing the alignment procedure (install aperture on the transmitter, not on the receiver). If the separation distance is between 5–40 meters and signal saturation is indicated after completion of the Basic Alignment procedure, an aperture will be required (even if no aperture was originally installed). Refer to the “Aperture Kit for Short Range Applications” section of this manual for complete information regarding apertures.

- Perform a zero calibration of the detector.

- Upon completion of zero calibration, verify proper operation by performing an “optical test film test” and also a “beam block test” (see steps 20 and 21 in the “Basic Alignment Procedure” section in this manual).

### NOTE

Replacement receiver modules are furnished from the factory with default configuration settings. If the LS2000 system has had any configuration changes in the field, the new receiver will require changes to configuration parameters using a HART communicator, a FlexVu UD10 display unit, or Modbus communication.

- Restore system alarms (remove bypass).

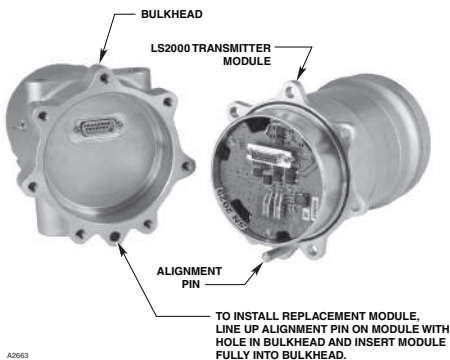

Figure 30—Transmitter Module Removed from Bulkhead

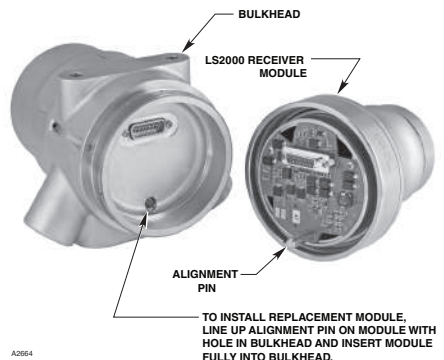

Figure 31—Receiver Module Removed from Bulkhead

## DEVICE REPAIR AND RETURN

The LS2000 IR Hydrocarbon Gas Detector is not designed to be repaired in the field. If a problem should develop, first carefully check for proper wiring, programming and calibration. If it is determined that the problem is caused by an electronic failure, the device must be returned to the factory for repair.

Prior to returning devices, contact the nearest local Detector Electronics office so that a Return Material Authorization (RMA) number can be assigned. A written statement describing the malfunction must accompany the returned device or component to assist and expedite finding the root cause of the failure.

### NOTE

Please refer to the Det-Tronics website for additional information and support of the RMA process:  
<https://www.det-tronics.com/Products/repair-and-warranty-services>

Pack the unit properly. Always use sufficient packing material. Where applicable, use an antistatic bag as protection from electrostatic discharge.

### NOTE

Inadequate packaging that ultimately causes damage to the returned device during shipment will result in a service charge to repair the damage incurred during shipment.

Return all equipment transportation prepaid to the factory in Minneapolis.

## ORDERING INFORMATION

When ordering, please refer to the LS2000 Model Matrix:

### ALIGNMENT EQUIPMENT

Part Number	Description
012287-002	LS2000 Alignment Tool consists of a 32mm sighting device with 3-9x zoom magnifier that is factory assembled with precision holder and reflective mirror.

## ACCESSORIES

Part Number	Description
011773-001	Short Range Aperture Kit
012673-001	System Test Films (set of 5 films)
103922-003	HART AMS Trex™ device communicator
009246-003	High Range Gas Test Cell
009246-004	Gas Test Cell, LS2000 Methane IEC
009246-005	Gas Test Cell, LS2000 Propane ISO
009246-006	Gas Test Cell, LS2000 Propane IEC
009246-007	Gas Test Cell, LS2000 Butane ISO
009246-008	Gas Test Cell, LS2000 Butane IEC
012354-001	3/4" NPT Stopping plugs
012351-001	M25 Stopping plugs
012353-001	M25/M20 Reducer
012312-001	Transmitter Brow
012300-001	Receiver Brow
012718-003	Flat Surface Mounting Plate
012790-001	Thermal Shield, Right
012791-001	Thermal Shield, Left

## SPARE PARTS

Part Number	Description
102740-002	Calibration Magnet
104346-154	O-Ring, 3.75" i.d., for wiring compartment cover
104346-046	O-Ring, 4.25", for front flange, Transmitter
400525-023	M8 Flange Bolt
012660-001	Spare Mounting and Alignment Bracket (for one LS2000 module only)
103578-001	Anti-Sieze Lubricant Packet

## LS2000 MODEL MATRIX

MODEL	DESCRIPTION
LS2000	Line-of-Sight Infrared Gas Detector
TYPE	MATERIAL
S	Stainless Steel
TYPE	CONDUIT ENTRY THREAD TYPE
N	3/4" NPT, 4 Port Receiver, 2 Port Transmitter
M	Metric M25, 4 Port Receiver, 2 Port Transmitter
TYPE	OUTPUT
00	None (Transmitter only)
14	Eagle Quantum Premier (EQP)
18	4-20 mA, RS485, HART (Receiver or Kit)
25	4-20 mA, RS485, HART w/Optional Relays (Receiver or Kit) – Ex d only
TYPE	RANGE
N	None (Transmitter only)
S	Short Range, 5-60 Meters (Receiver or Kit)
L	Long Range, 30-120 Meters (Receiver or Kit)
TYPE	FACTORY SET TARGET GAS*
N	None (Transmitter only)
M	Methane (Receiver or Kit)
P	Propane (Receiver or Kit)
B	Butane (Receiver or Kit)
TYPE	APPROVALS†
A	FM/CSA
B	INMETRO (Brazil)
E	ATEX/IECEX
R	VNIIFTRI (Russia)
S	SIL
TYPE	CLASSIFICATION
1	Division and/or Ex d e
2	Division and/or Ex d
TYPE	CONFIGURATION
S	Transmitter/Receiver/Mounting Hardware
T	Transmitter Only
R	Receiver Only
TM	Spare Transmitter Electronics Module
RM	Spare Receiver Electronics Module

\*The LS2000 is factory calibrated to Methane, Propane, and Butane gas types. This selection indicates which gas type the device was configured to detect when it left the factory. This selection can be changed in the field via HART or Modbus.

†Type Approvals can use one or more letters to designate the approvals of the product.

NOTE: "Kit" is a complete system, consisting of a transmitter, receiver, aperture, and mounting hardware.

## APPENDIX A

### FM APPROVAL DESCRIPTION

The following items, functions, and options describe the FM approval.

#### APPROVAL

Line-of-Sight Infrared Hydrocarbon Gas Detector, Model LS2000.

##### Receiver with or without Relays

Class I, Div. 1, Groups B, C & D (T4).

Class I, Div. 2, Groups A, B, C & D (T4).

Class II/III, Div. 1 & 2, Groups E, F & G (T4).

Tamb = -50°C to +65°C.

Class I, Zone 1, AEx db IIC T4 IP66/67.

Tamb = -50°C to +65°C.

Type 4X, IP66/67.

##### Receiver without Relays

Class I, Div. 1, Groups B, C & D (T4).

Class I, Div. 2, Groups A, B, C & D (T3C).

Class II/III, Div. 1, Groups E, F & G (T4).

Class II/III, Div. 2, Groups E, F & G (T3C).

Tamb = -50°C to +75°C.

Class I, Zone 1, AEx db eb IIC T4 IP66/67.

Tamb = -50°C to +75°C.

Type 4X, IP66/67.

##### Transmitter

Class I, Div. 1, Groups B, C & D (T4).

Class I, Div. 2, Groups A, B, C & D (T3C).

Class II/III, Div. 1, Groups E, F & G (T4).

Class II/III, Div. 2, Groups E, F & G (T3C).

Tamb = -50°C to +75°C.

Class I, Zone 1, AEx db IIC T4 IP66/67.

Class I, Zone 1, AEx db eb IIC T4 IP66/67.

Tamb = -50°C to +75°C.

Type 4X, IP66/67.

Conduit seal required within 18 inches (450mm) of the enclosure.

Performance verified in accordance with FM 6325, ANSI/ISA 12.13.04 for Methane, Propane, and Butane.

LS2000 hazardous location and performance testing was successfully completed down to -55°C. However, the FM approved rating is limited to -50°C as there are no conduit fittings, cables, or cable glands that are presently listed for use below -50°C in the US. FM approvals policy does not allow product temperature ratings to exceed required installation components (such as conduit seals). The user must ensure that conduit fittings, cables, cable glands, etc. are rated for the expected minimum ambient temperature of the installation.

#### ACCURACY

±5% of full scale gas concentration or ±10% of applied gas concentration, whichever is greater.

#### NOTE

In order to remain within ±5% of full scale gas concentration or ±10% of applied gas concentration, the maximum misalignment is ±0.8 degrees.

## RESPONSE TIME

T90: 2 seconds (2.5 LFL-meters applied).  
Note: Add 1 second to response time for EQP compatible models

### NOTES

Approval of the LS2000 does not include or imply approval of the apparatus to which the detector may be connected and which processes the electronic signal for eventual end use. In order to maintain an approved system, the apparatus to which the detector is connected must also be approved.

This Approval does not include or imply Approval of the communications protocol or functions provided by the software of this instrument or the communications apparatus or software connected to this instrument.

The LS2000 may be used with FM Approved PointWatch Termination Box Model PIRTB Series.

Accessories with the following part numbers are approved for use with the LS2000:

011773-001	Short Range Aperture Kit
012287-XXX	LS2000 Alignment Tool
009246-003	High Range Gas Test Cell
009246-004	Gas Test Cell, LS2000 Methane IEC
009246-005	Gas Test Cell, LS2000 Propane ISO
009246-006	Gas Test Cell, LS2000 Propane IEC
009246-007	Gas Test Cell, LS2000 Butane ISO
009246-008	Gas Test Cell, LS2000 Butane IEC
012673-001	System Test Film (set of 5 films)
012312-001	Transmitter Brow
012300-001	Receiver Brow
012660-001	Mounting and Alignment Bracket
103922-003	HART AMS Trex™ Device Communicator
011824-001	LS2000 Inspector Software
102740-002	Calibration Magnet

### FM Standards:

Class 3010	2014
Class 3600	2011
Class 3611	2004
Class 3615	2006
Class 3616	2011
Class 3810	2005
Class 6325	2005
ANSI/ISA 12.13.04	2007
ANSI/NEMA 250	2008
ANSI/IEC 60529	2004



## APPENDIX B

### CSA CERTIFICATION DESCRIPTION

The following items, functions, and options describe the CSA certification.

#### APPROVAL

Line-of-Sight Infrared Hydrocarbon Gas Detector, Model LS2000.

#### Receiver with Relays

Class I, Div. 1, Groups B, C, & D (T4).

Tamb = -55°C to +75°C.

Class I, Div. 2, Groups A, B, C, & D (T4).

Class II/III, Div. 1 & 2, Groups E, F, & G (T4).

Tamb = -55°C to +65°C.

Class I, Zone 1, Ex db IIC T4 IEC 60079-29-4 IP66/67.

Tamb = -55°C to +75°C.

Type 4X, IP66/67.

#### Receiver without Relays

Class I, Div. 1, Groups B, C, & D (T4).

Class I, Div. 2, Groups A, B, C, & D (T3C).

Class II/III, Div. 1, Groups E, F, & G (T4).

Class II/III, Div. 2, Groups E, F, & G (T3C).

Tamb = -55°C to +75°C.

Class I, Zone 1, Ex db eb IIC T4 IEC 60079-29-4 IP66/67.

Tamb = -50°C to +75°C.

Class I, Zone 1, Ex db IIC T4 IEC 60079-29-4 IP66/67.

Tamb = -55°C to +75°C.

Type 4X, IP66/67.

#### Transmitter

Class I, Div. 1, Groups B, C & D (T4).

Class I, Div. 2, Groups A, B, C & D (T3C).

Class II/III, Div. 1, Groups E, F & G (T4).

Class II/III, Div. 2, Groups E, F & G (T3C).

Tamb = -55°C to +75°C.

Class I, Zone 1, Ex db eb IIC T4 IEC 60079-29-4 IP66/67.

Tamb = -50°C to +75°C.

Class I, Zone 1, Ex db IIC T4 IEC 60079-29-4 IP66/67.

Tamb = -55°C to +75°C.

Type 4X, IP66/67.

Conduit seal required within 18 inches (450mm) of the enclosure.

#### ACCURACY

±5% of full scale gas concentration or ±10% of applied gas concentration, whichever is greater.

#### NOTE

In order to remain within ±5% of full scale gas concentration or ±10% of applied gas concentration, the maximum misalignment is ±0.8 degrees.

## RESPONSE TIME

T90: 2 seconds (2.5 LFL-meters applied).  
Note: Add 1 second to response time for EQP compatible models

## NOTES

Approval of the LS2000 does not include or imply approval of the apparatus to which the detector may be connected and which processes the electronic signal for eventual end use. In order to maintain an approved system, the apparatus to which the detector is connected must also be approved.

This Approval does not include or imply Approval of the communications protocol or functions provided by the software of this instrument or the communications apparatus or software connected to this instrument.

The LS2000 may be used with CSA Certified PointWatch Termination Box Model PIRTB Series.

Accessories with the following part numbers are approved for use with the LS2000:

011773-001	Short Range Aperture Kit
012287-XXX	LS2000 Alignment Tool
009246-003	High Range Gas Test Cell
009246-004	Gas Test Cell, LS2000 Methane IEC
009246-005	Gas Test Cell, LS2000 Propane ISO
009246-006	Gas Test Cell, LS2000 Propane IEC
009246-007	Gas Test Cell, LS2000 Butane ISO
009246-008	Gas Test Cell, LS2000 Butane IEC
012673-001	System Test Film (set of 5 films)
012312-001	Transmitter Brow
012300-001	Receiver Brow
012660-001	Mounting and Alignment Bracket
103922-003	HART AMS Trex™ Device Communicator
011824-001	LS2000 Inspector Software
102740-002	Calibration Magnet

CSA Standards:

- C22.2 No. 0-10 (R2015)
- C22.2 No. 25-1966 (R2014)
- C22.2 No. 30M1986 (R2012)
- C22.2 No. 94-M91 (R2011)
- C22.2 No. 142-M1987 (R2014)
- C22.2 No. 213-M1987 (R2013)
- C22.2 No. E60079-0: 2007
- C22.2 No. E60079-1: 2011
- C22.2 No. E60079-7: 2012
- C22.2 No. 60529 (R2015)

## APPENDIX C

### ATEX APPROVAL DESCRIPTION

The following items, functions, and options describe the ATEX approval.

#### APPROVAL

Line-of-Sight Infrared Hydrocarbon Gas Detector, Model LS2000.

##### Receiver

CE 0539 Ex II 2 G  
DEMKO 15 ATEX 1386X  
Ex db eb IIC T4 EN 60079-29-4 IP66/67  
T4 (Tamb -50°C to +75°C)  
(Receiver without relays)  
--OR--  
Ex db IIC T4 EN 60079-29-4 IP66/67  
T4 (Tamb -55°C to +75°C)  
(Receiver with or without relays)

##### Transmitter

CE 0539 Ex II 2 G  
DEMKO 15 ATEX 1386X  
Ex db eb IIC T4 EN 60079-29-4 IP66/67  
T4 (Tamb -50°C to +75°C)  
--OR--  
Ex db IIC T4 EN 60079-29-4 IP66/67  
T4 (Tamb -55°C to +75°C)

Performance verified with Methane, Butane, and Propane in accordance with EN 60079-29-4.

#### ATEX Special Conditions for Safe Use (general):

- The Model LS2000 shall be installed in places where there is low risk of mechanical damage.
- The field wiring terminal connections are certified for a single wire in size from 0.2–2.5 mm<sup>2</sup>, (or two conductors with same cross section 0.2 to 0.75 mm<sup>2</sup>). The screws must be tightened down with a torque of 0.4–0.5 Nm.
- The metal housings of the Model LS2000 Gas Detector must be electrically connected to earth ground.
- The Model LS2000 has an ambient temperature rating of -55°C to +75°C.
- Only suitable certified Ex d or Ex e (as applicable) cable entries, adapters, and blanking elements are to be used, including 1/2 inch NPT, 3/4 inch NPT, M20 and M25 sizes, with IP66/67 rating.
- Flameproof joints are not user serviceable; contact Det-Tronics Service.
- Seven special fasteners are provided for the Transmitter electronics module, M8 bolts per ISO 965 with M6 head, SST with a yield strength of 483 N/mm<sup>2</sup> (70,000 PSI). The tightening torque in an opposing order is 19 Nm (169 inch-pounds) per flange bolt.

#### WARNING

Always ensure that the detector/junction box hazardous (classified) location ratings are applicable for the intended use.

#### WARNING

Potential electrostatic charging hazard on brow. Use caution when servicing in an explosive environment.

#### Additional Safety Notes:

- For ambient temperatures below -10°C, use field wiring suitable for the expected conditions, and for ambient temperatures above +60°C, use field wiring and cable glands suitable for 15°C above the maximum expected conditions.

**ATEX Standards:**

EN 60079-29-4: 2010

Performance Approved for Methane, Butane, and Propane.

EN 60079-0: 2012 +A11:2013

EN 60079-1: 2014

EN 60079-7: 2015

EN 60079-28:2007

EN 60529:1991+A1:2000

EN 50270: 2015

EN 50271: 2010

CE: Conforms to:

Low Voltage Directive: 2014/35/EU,

EMC Directive: 2014/30/EU,

ATEX Directive: 2014/34/EU, WEEE 2002/96/EC.

**ACCURACY (PER EN 60079-29-4)**

±5% of full scale gas concentration or ±10% of applied gas concentration, whichever is greater.

**NOTE**

In order to remain within ±5% of full scale gas concentration or ±10% of applied gas concentration, the maximum misalignment is ±0.8 degrees.

**RESPONSE TIME**

T90: 2 seconds (2.5 LFL-meters applied).

Note: Add 1 second to response time for EQP compatible models

**ALIGNMENT**

Misalignment (up to a maximum ±0.8 degrees) will cause the manufacturer stated accuracy limits to increase, but remain within the limits of EN 60079-29-4.

Accessories with the following part numbers are approved for use with the LS2000:

011773-001	Short Range Aperture Kit
012287-002	LS2000 Alignment Tool
009246-003	Gas Test Cell, Methane, ISO*
009246-004	Gas Test Cell, Methane, IEC
009246-005	Gas Test Cell, Propane, ISO
009246-006	Gas Test Cell, Propane, IEC
009246-007	Gas Test Cell, Butane, ISO
009246-008	Gas Test Cell, Butane, IEC
012673-001	System Test Film (set of 5 films)
012312-001	Transmitter Brow
012300-001	Receiver Brow
012660-001	Mounting and Alignment Bracket
103922-003	HART AMS Trex™ Device Communicator

\*ISO = NFPA 497

IEC = IEC 60079-20-1

011824-001	LS2000 Inspector Software
102740-002	Calibration Magnet

#### NOTES

Approval of the LS2000 does not include or imply approval of the apparatus to which the detector may be connected and which processes the electronic signal for eventual end use. In order to maintain an approved system, the apparatus to which the detector is connected must also be approved.

This Approval does not include or imply Approval of the communications protocol or functions provided by the software of this instrument or the communications apparatus or software connected to this instrument.

## APPENDIX D

### IECEx APPROVAL DESCRIPTION

The following items, functions, and options describe the IECEx approval.

#### APPROVAL

Line-of-Sight Infrared Hydrocarbon Gas Detector, Model LS2000.

##### Receiver

IECEx UL 15.0037X

Ex db eb IIC T4 IEC 60079-29-4 IP66/67

T4 (Tamb -50°C to +75°C)

(Receiver without relays)

--OR--

Ex db IIC T4 IEC 60079-29-4 IP66/67

T4 (Tamb -55°C to +75°C)

(Receiver with or without relays)

##### Transmitter

IECEx UL 15.0037X

Ex db eb IIC T4 IEC 60079-29-4 IP66/67

T4 (Tamb -50°C to +75°C)

--OR--

Ex db IIC T4 IEC 60079-29-4 IP66/67

T4 (Tamb -55°C to +75°C)

Performance verified with Methane, Butane, and Propane in accordance with IEC 60079-29-4.

#### IEC Standards:

IEC 60079-0: 2011

IEC 60079-1: 2014

IEC 60079-7: 2015

IEC 60079-28:2006

IEC 60529, 2.1 ed.+Corr.1:2003+2:2007

IEC 61000-4-1:2006

IEC 61000-4-3:2010

IEC 61000-4-4:2012

IEC 60079-29-4:2010

Performance Approved for Methane, Butane, and Propane

#### IEC Conditions of Certification (general):

- Only suitable certified Ex d or Ex e (as applicable) cable entries, adapters, and blanking elements are to be used, including 1/2 inch NPT, 3/4 inch NPT, M20 and M25 sizes, with IP66/67 rating.
- The Model LS2000 assemblies are to be installed in places where there is a low risk of mechanical damage.
- The field wiring terminal connections are certified for a single wire in size from 0.2 to 2.5 mm<sup>2</sup>, (or two conductors with same cross section 0.2 to 0.75 mm<sup>2</sup>). The screws must be tightened down with a torque 0.4 to 0.5 Nm.
- The metal housings of the Model LS2000 Gas Detector must be electrically connected to earth ground.
- Flameproof joints are not user serviceable; contact Det-Tronics Service.
- Seven special fasteners are provided for the Transmitter electronics module, M8 bolts per ISO 965 with M6 head, SST with a yield strength of 483 N/mm<sup>2</sup> (70,000 PSI). The tightening torque in an opposing order is 19 Nm (169 inch-pounds) per flange bolt.
- The following additional previous editions of Standards noted under the "Standards" section of the Certificate where applied to integral Components as itemized below. There are no significant safety related changes between these previous editions and the editions noted under the "Standards" section.

Phoenix Contact Terminal Block Model Front 2.5

IEC 60079-7:2001, IEC 60079-0:2004

**⚠ WARNING**

Always ensure that the detector/junction box hazardous (classified) location ratings are applicable for the intended use.

**⚠ WARNING**

Potential electrostatic charging hazard on brow. Use caution when servicing in an explosive environment.

**Additional Safety Notes:**

- For ambient temperatures below  $-10^{\circ}\text{C}$ , use field wiring suitable for the expected conditions, and for ambient temperatures above  $+60^{\circ}\text{C}$ , use field wiring and cable glands suitable for  $15^{\circ}\text{C}$  above the maximum expected conditions.

**ACCURACY (per IEC 60079-29-4)**

$\pm 5\%$  of full scale gas concentration or  $\pm 10\%$  of applied gas concentration, whichever is greater.

**NOTE**

In order to remain within  $\pm 5\%$  of full scale gas concentration or  $\pm 10\%$  of applied gas concentration, the maximum misalignment is  $\pm 0.8$  degrees.

**RESPONSE TIME**

T90: 2 seconds (2.5 LFL-meters applied).  
Note: Add 1 second to response time for EQP compatible models

**ALIGNMENT**

Misalignment (up to a maximum  $\pm 0.8$  degrees) will cause the manufacturer stated accuracy limits to increase, but remain within the limits of IEC 60079-29-4.

Accessories with the following part numbers are approved for use with the LS2000:

011773-001	Short Range Aperture Kit	
012287-002	LS2000 Alignment Tool	
009246-003	Gas Test Cell, Methane ISO*	
009246-004	Gas Test Cell, Methane IEC	
009246-005	Gas Test Cell, Propane ISO	
009246-006	Gas Test Cell, Propane IEC	
009246-007	Gas Test Cell, Butane ISO	
009246-008	Gas Test Cell, Butane IEC	
012673-001	System Test Film (set of 5 films)	
012312-001	Transmitter Brow	
012300-001	Receiver Brow	
012660-001	Mounting and Alignment Bracket	*ISO = NFPA 497 IEC = IEC 60079-20-1
103922-001	HART Handheld Communicator	
011824-001	LS2000 Inspector Software	
102740-002	Calibration Magnet	

**NOTES**

Approval of the LS2000 does not include or imply approval of the apparatus to which the detector may be connected and which processes the electronic signal for eventual end use. In order to maintain an

approved system, the apparatus to which the detector is connected must also be approved.

This Approval does not include or imply Approval of the communications protocol or functions provided by the software of this instrument or the communications apparatus or software connected to this instrument.



# APPENDIX E

## ADDITIONAL APPROVALS

The following items, functions, and options describe various other approvals applicable to the LS2000.

### SIL APPROVAL



IEC 61508: 2010 Parts 1-7

Certified SIL 2 Capable.

Refer to the Safety Reference Manual (form number 95-8727) for details.

DNV GL



Type Approval Certificate No. TAA000002M.

Subject Matter of the Approval

FlexSight™ LS2000 Line-of-Sight Infrared Gas Detector is found to comply with Det Norske Veritas' Rules for Classification of Ships and Det Norske Veritas' Offshore Standards.

Application

Location Classes					
MODEL	TEMPERATURE	HUMIDITY	VIBRATION	EMC	ENCLOSURE
LS2000	D	B	A/B	B	C/IP66/IP67

Relevant tests according to "Standard for Certification No. 2.4."

Location classes for LS2000 (Shaded areas show Det-Tronics approved location classes)

COLUMN 1		COLUMN 2 MAIN AREAS ON BOARD				
TYPE	LOCATION WITHIN MAIN AREA	Machinery spaces	Control room, Accommodation	Bridge	Pump room, Holds, Rooms with no heating	Open Deck
Temperature	Inside cubicles, desks, etc. with temperature rise of 5°C or more	B	B	B	D	D
	All other locations	A	A	A	C	D
Humidity	Locations where special precautions are taken to avoid condensation	A	A	A	A	A
	All other locations	B	B	B	B	B
Vibration	On machinery such as internal combustion engines, compressors, pumps, including piping on such machinery	B	—	—	B	B
	Masts	—	—	—	—	—
	All other locations	A	A	A	A	A
EMC (Electromagnetic compatibility)	All locations within specified main areas	A	A	B	A	B
Enclosure	Submerged application	D	—	—	D	D
	Below floor plates in engine room	C	—	—	—	—
	All other locations	B	A	A	B	C

INMETRO



UL-BR 15.0742X

Ex db eb IIC T4

Ex db IIC T4

IP66/67

-50°C ≤ Tamb ≤ +75°C (for Ex db eb version)

-55°C ≤ Tamb ≤ +75°C (for Ex db version)

RUSSIA & KAZAKHSTAN



VNIIFTRI

CERTIFICATE OF CONFORMITY TO "TP TC 012/2011"

Nº TC RU C-US. BH02.B.00070

2ExdellICT4 X

T4 (Tamb = -50°C to +75°C)

IP66

- OR -

1ExdIICT4 X

T4 (Tamb = -55°C to +75°C)

IP66

KAZAKHSTAN



COMMITTEE FOR TECHNICAL REGULATIONS  
AND METROLOGY

PAC CERTIFICATE Nº 12228

# APPENDIX F

## HART COMMUNICATION

Digital communication with the LS2000 is necessary to monitor internal status and to modify the factory settings. This appendix provides guidance on establishing HART communication, and describes the communication menu structure when using the LS2000 with the HART Handheld Communicator.

### INTERCONNECTING THE HART COMMUNICATOR WITH THE LS2000

#### WARNING

Declassify the area prior to removing the LS2000 module's terminal cover.

Connect the HART Communicator to the LS2000. Press the "on" key to switch on the HART Communicator. The Online menu is the first menu to appear when the Communicator is properly connected to the LS2000. This menu is structured to provide important information about the connected device immediately on powering up the Communicator. This menu displays up-to-date device information including primary variable, analog output, lower range value, and upper range value.

#### NOTE

The HART protocol incorporates a concept called the "Device Description Language" that enables all suppliers of HART instruments to define and document their products in a single consistent format. This format is readable by handheld communicators, PC's and other process interface devices that support DDL. DDL enables full interoperability of devices, regardless of manufacturer, allowing full functionality from any HART device.

In the event that your Communicator does not establish communications with the LS2000, you may need to ensure that the appropriate DDLs for the LS2000 are included within your Communicator. To review the device descriptions programmed into your HART Communicator:

1. From the Main menu, press to access Offline menu.
2. From the Offline menu, press New Configurations to access the list of device descriptions programmed into your HART Communicator. The Manufacturer menu displays a list of each manufacturer with device descriptions currently installed in your Communicator's Memory Module. The standard 12 MB Memory Module is recommended, as it allows for more device descriptions.
3. Select Det-tronics, and the Model menu displays, containing a list of currently installed device models provided by the selected manufacturer.
4. Review the different manufacturers and models to determine the installed HART-compatible devices in your Communicator.

If you cannot find the LS2000 device on your Communicator, the device revision you are looking for is not programmed into the Memory Module. In this instance, you are limited to what is available using the generic interface built into your HART Communicator.

The HART Communication Foundation ([www.ccsi.com/hart](http://www.ccsi.com/hart)) manages a library of Manufacturer Device Descriptions, which are distributed to programming sites for inclusion in master devices. A complete listing of the HCF DD Library is available for download in manufacturer and device type sequence.

#### NOTE

If a device is found, the HART Communicator displays the Online menu. If no device is found, the Communicator displays the Main menu. If no device is found, check the connections, verify the presence of a minimum of 250 ohms load resistance in series in the loop, and retry by selecting 'Online.' To poll multiple devices in the loop, refer to the HART Communicator manual.

# LS2000 HART MENU STRUCTURE

This section displays the menu trees for the LS2000. The Menu tree shows the primary commands and options available when using menu selections.

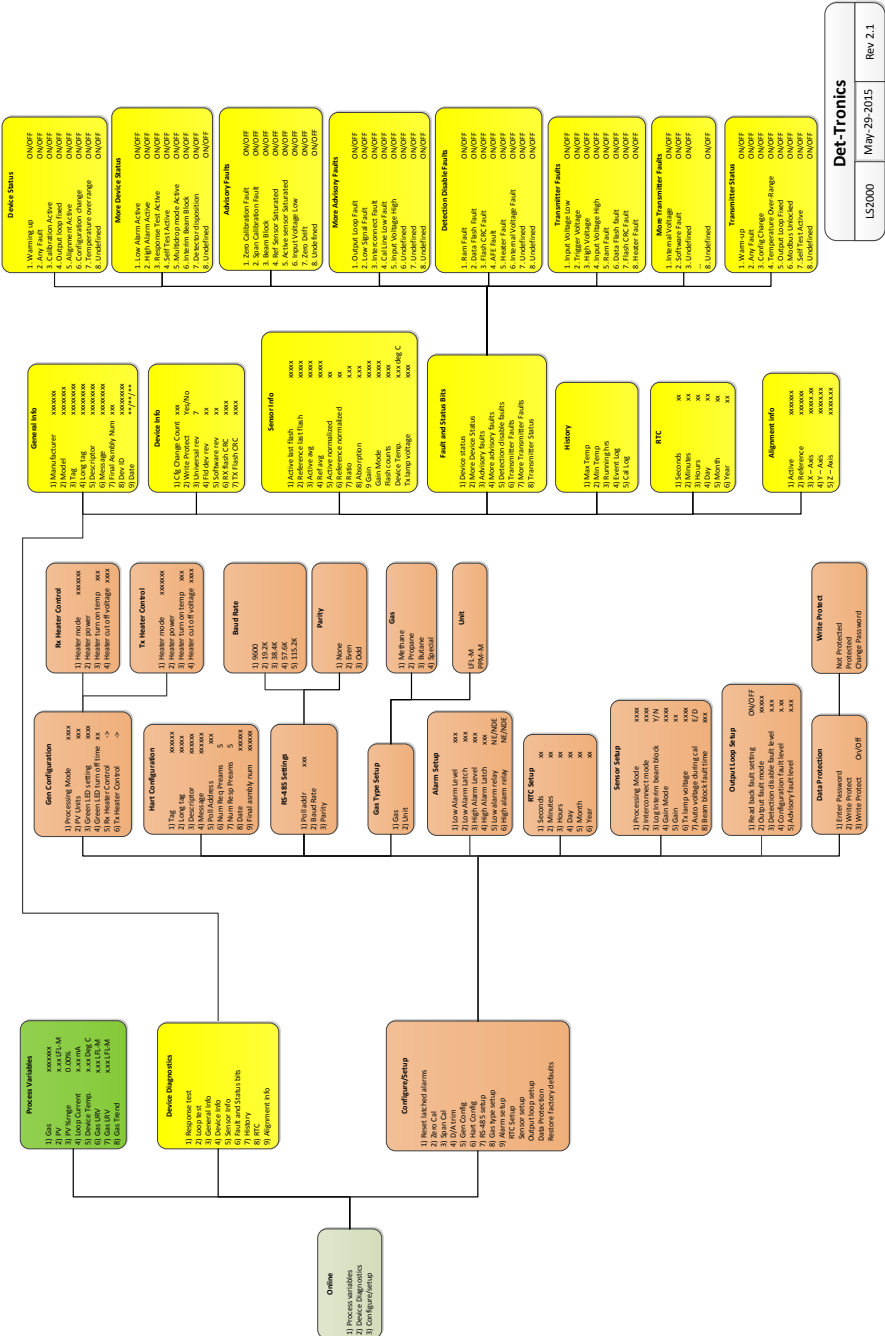

## CONNECTIONS AND HARDWARE

The HART Communicator can interface with the LS2000 from the control room or from any wiring termination point in the analog output signal loop. To communicate, connect the HART communicator in parallel with the LS2000 analog signal or load resistor. The connections are non-polarized. Refer to the "Wiring Procedure" section for installation instructions.

### NOTE

The HART Communicator needs a minimum of 250 ohms resistance in the loop to function properly. The HART Communicator does not measure loop current directly.

### WARNING

Declassify the area prior to removing the LS2000 module's terminal cover.

## ONLINE MENU

When HART communication is established with the receiver, the first menu displayed is the LS2000 Online menu:

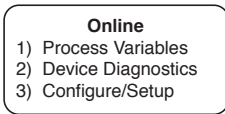

To select any of the menu options shown, highlight the desired option using the up/down arrow key, and then press the "right arrow" key.

## COMMONLY USED HART COMMANDS

The most commonly used HART commands for the LS2000 are:

1. Setting the real time clock
2. Setting alarm thresholds and latch/nonlatch functions
3. Setting the analog fault code menu
4. Performing full system alignment
5. Performing zero calibration
6. Assigning a nonvolatile tag name to the receiver
7. Defining a nonvolatile descriptor for future reference
8. Interrogating the history menu for information including total running hours, max/min temperature, calibration and event logs.

### NOTE

Password protection (default value = off) prevents changes to all parameters. Default HART write protect password is OPECL. The password must be entered and sent to the device to change between write protected and unprotected modes.

### NOTE

Each time the HART handheld is disconnected from the receiver (Rx) the password must be reentered to make any modifications.

## HART MENU DESCRIPTIONS FOR THE LS2000

LS2000 HART Menu Description	
Process Variables	
Gas	Name of the selected gas type
PV	Process Variable in LFL-M
PV % Range	Percent of full-scale
Loop Current	Current flow in the 4-20 loop
Device Temp	Internal temperature
Gas URV	Upper Range Value (5 LFL-M)
Gas LRV	Lower Range Value (0 LFL-M)
Gas Trend	Display the gas trend graph
Device Diagnostics	
Response Test	Used to initiate the response test - This allows users to conduct a gas response test as the unit maintains a 4mA output. The unit will automatically return to normal operation in 10 minutes if this mode is not exited by the user. The gas level, remaining time, and a number of other variables are displayed while in this mode. The Response Test can be conducted using Test Films or Gas Cell.
Loop Test	This allows the user to manually control the 4-20mA output. The unit will automatically return to normal operation in 10 minutes if this mode is not exited by the user.
General Info	Sub Menu Selection
Device Info	Sub Menu Selection
Sensor Info	Sub Menu Selection
Fault and Status bits	Sub Menu Selection
History	Sub Menu Selection
RTC	Sub Menu Selection
Alignment Info	Sub Menu Selection
Configure/Setup	
Reset Latched Alarms	Resets latched alarm relays if the gas level is below the alarm threshold.
Zero Cal	Initiate zero gas calibration
Span Cal	Initiate span gas calibration. The LS2000 is factory calibrated under controlled conditions and field calibration is not recommended.
D/A Trim	Used to trim the 4-20mA output
Gen Config	Sub Menu Selection
Hart Config	Sub Menu Selection
RS-485 Setup	Sub Menu Selection
Gas Type Setup	Sub Menu Selection
Alarm Setup	Sub Menu Selection
RTC Setup	Sub Menu Selection
Sensor Setup	Sub Menu Selection
Output Loop Setup	Sub Menu Selection
Data Protection	Sub Menu Selection
Restore Factory Defaults	<b>CAUTION:</b> This feature is not fully supported and should not be used.
Gen Configuration	
Processing Mode	Used to select Normal or Quick processing mode. Quick mode provides less filtering and normal mode is recommended.
PV Units	Used to select engineering units and %LFL-M is recommended.
Green LED Setting	This allows the user to disable the green LED on the detector
Green LED turn off time	This sets how long the unit will wait to turn the green LED off after it returns to normal operation.
RX Heater Control	Sub Menu Selection
TX Heater Control	Sub Menu Selection
HART Configuration	
Tag	Tag name
Long Tag	Long Tag name
Descriptor	User Descriptor for this device
Message	Available for user message
Poll Address	HART polling address. Should be left at zero
Num Req Preams	Number of request preambles
Num Resp Preams	Number of response preambles
Date	Date field for user use
Final assembly num	Final Assembly Number/Serial Number
RS-485 Settings	
Poll Addr	MODBUS address (1..247)
Baud Rate	Used to select RS485 baud rate - 115K is default
Parity	Used to select RS485 baud rate - None is default

## LS2000 HART Menu Description

### Gas Type Setup

Gas Type Setup	Select gas type
Unit	Select Engineering Units

### Alarm Setup

Low Alarm Level	Sets Alarm Level
Low Alarm Latch	Select latching/non-latching alarm relay
High Alarm Level	Sets Alarm Level
High Alarm Latch	Select latching/non-latching alarm relay
Low Alarm Relay NE/NDE	Normally Energized/Normally Non-Energized
High Alarm Relay NE/NDE	Normally Energized/Normally Non-Energized

### RTC Setup

Seconds	Used to set the real time clock
Minutes	
Hours	
Day	
Month	
Year	

### Sensor Setup

Processing Mode	Used to select Normal or Quick processing mode. Quick mode provides less filtering and normal mode is recommended.
Interconnect Mode	Select if the interconnect is used, the RX will signal a fault if this is selected and the interconnect is not attached.
Log Interim Beam Block	Select if short term beam block faults should be logged. Most users don't log short term beam block events because it can fill the logs in an environment that has frequent short term beam block events. The default is off.
Gain Mode	Gain mode should remain in automatic mode and users can't change it from this interface.
Gain	Displays the current gain setting (1..100)
TX Lamp Voltage	The default setting is 750V and changes are not recommended without consulting with the factory.
Auto Voltage During Cal	If the interconnect is used this will allow the RX to automatically adjust the TX lamp output during zero calibration. For best accuracy utilizing this feature is not recommended.
Beam Block Fault Time	Sets the delay time in seconds before a beam block fault is announced as a fault. If only short intermittent beam block events are expected this can be set to a shorter time. The default time is 60 seconds.

### Output Loop Setup

Read Back Fault Setting	Enabling this will cause the device to generate a fault if the measured 4-20 output value does not equal the driven value. This fault can be caused by failed circuitry within the unit or if the loop is not terminated correctly. Enabling this feature is recommended for SIL 2 systems. The default is off.
Output Fault Mode	Selects the 4-20 mA fault mode (LS2000, Advanced, User Defined) - LS2000 is the default mode
Detection Disabled Fault Level	Sets the output current level for faults in the Detection Disabled category. 2.00 is the default
Configuration Fault Level	Sets the output current level for faults in the Configuration Fault category. 1.00 is the default
Advisory Fault Level	Sets the output current level for faults in the Advisory Fault category. 3.00 is the default

### Data Protection

Enter Password	Used to enter the password (OPECL is default)
Write Protect	Used to enable or disable the write protect feature The default is "Not Protected".
Write Protect On/Off	Displays the current Write Protect status

### RX Heater Control

Heater Mode	Always Off, On, Smart mode (default)
Heater Power	10-100% (100%) is default
Heater Turn On Temp	In Smart Mode the heater will be turned when the device is below this value. 50C is the default.
Heater Cut Off Voltage	In smart mode the heater will turn off when the input voltage drops below value. 18.5 volts is the default value. This feature is provided for users who want the heater to go off if the system power drops or is switched to a battery.

LS2000 HART Menu Description	
TX Heater Control	
Heater Mode	Always Off, On, Smart mode (default)
Heater Power	10-100% (100%) is default
Heater Turn On Temp	In Smart Mode the heater will be turned when the device is below this value. 50C is the default.
Heater Cut Off Voltage	In smart mode the heater will turn off when the input voltage drops below value. 18.5 volts is the default value. This feature is provided for users who want the heater to go off if the system power drops or is switched to a battery.
General Info	
Manufacture	Det-Tronics
Model	LS2000
Tag	Tag name (User entry)
Long Tag	Long Tag name (User entry)
Descriptor	User Descriptor for this device (User entry)
Message	User message
Final Assembly Num	Final Assembly Number/Serial Number
Dev ID	Device ID
Date	Date Field

Device Info	
Cfg Change Count	Number of time the configuration information has changed. This is used by HART masters to determine if new configuration information was downloaded.
Write Protect	Displays the current state of write protect.
Universal Rev	Revision of HART Universal commands used in the device (HART 7).
Fld dev rev	This is the field device hardware revision (1)
Software Rev	Software revision of the LS2000
RX Flash CRC	CRC value of RX flash memory
TX Flash CRC	CRC value of TX flash memory

Sensor Info	
Active Last Flash	Active sensor value during the last flash
Reference Last Flash	Reference sensor value during the last flash
Active avg	Averaged active sensor value
Ref avg	Averaged reference sensor value
Active Normalized	Normalized active sensor value
Reference Normalized	Normalized reference sensor value
Ratio	Ratio of active signal to reference signal
Absorption	Gas absorption value
Gain	Amplifier gain setting
Gain Mode	Current gain mode (Auto/Manual)
Flash Counts	Number of flashes detected by the RX
Device Temp	Internal temperature of the device
TX Lamp Voltage	TX Lamp Voltage

History	
Max Temp	Maximum internal temperature
Min Temp	Minimum internal temperature
Running hrs	Number of hours that the unit has been operational
Event Log	Sub Menu Selection
Cal Log	Sub Menu Selection

Alignment Info	
Active	Active signal level in ADC units.
Reference	Reference signal level in ADC units.
X-Axis	<b>Factory use only</b>
Y-Axis	
Z-Axis	



LS2000 HART Menu Description	
Device Status	
Warming up	The device in in warm-up mode
Any Fault	The device has a fault
Calibration Active	The device is being calibrated
Output Loop Fixed	The 4-20 mA output is in the fixed mode. The user can use this mode to force a value on the 4-20 line for system test or loop calibration of the receiving device.
Alignment Active	Not utilized
Configuration Change	A configuration parameter has been changed
Temperature over range	This fault is not supported
More Device Status	
Low Alarm Active	The low alarm is active
High Alarm Active	The high alarm is active
Response Test Active	The response test is active
Self Test Active	The LS2000 continually runs background self tests for SIL 2 so this bit is not utilized.
Multidrop Mode Active	Signals the device is in HART multidrop mode. Multidrop mode is not recommended for a safety device.
Interim Beam Block	This status bit goes active when the beam is blocked for approximately 10 seconds.
Detector Disposition	Not supported
Advisory Faults	
Zero Calibration Fault	Failed zero calibration - recalibrate to clear
Span Calibration Fault	Failed span calibration - recalibrate to clear
Beam Block	The beam was blocked longer then the beam block delay time
Ref Sensor Saturated	Reference sensor is saturated - Attach light blocking aperture to the TX
Active Sensor Saturated	Active sensor is saturated - Attach light blocking aperture to the TX
Input Voltage Low	The input voltage is low - Check input voltage
Zero Drift	Negative zero drift - Perform zero calibration to correct.

More Advisory Faults	
Output Loop Fault	The output loop current is not the same level as being drive. This fault is only active if the read back fault is enabled. Check that the output loop is properly connected and terminated.
Low Signal Fault	The light intensity is low and the RX is at the highest gain setting nearing a blocked beam condition. This can be caused by heavy fog or an object partially blocking the beam.
Interconnect Fault	This occurs when the interconnect feature is enabled and the RX and TX are not communicating. Check communication cable between the RX and TX.
Cal Line Low Fault	The calibration line was active when the device was powered up. Check wiring to the external calibration line.
Input Voltage High Fault	The input voltage is too high - Check input voltage

Detection Disable Faults	
Ram Fault	An error has been detected in RAM memory. Cycle power and if it returns consult factory.
Data Flash Fault	An error has been detected in the data area of memory. Consult factory.
Flash CRC Fault	An error has been detected in the code area of memory. Consult factory.
AFE Fault	An error was detected with the sensor amplifier. Consult factory.
Heater Fault	An error was detected with the heater. Consult factory.
Internal Voltage Fault	An error was detected with an internal power supply. Consult factory.

<b>NOTE: The interconnect wire between the RX and TX must be in place to view Transmitter faults from the RX</b>	
Transmitter Faults	
Input Voltage Low	The input voltage is low - Check input voltage
Trigger Voltage	The lamp trigger voltage is low - Consult factory.
High Voltage	The lamp high voltage is low - Consult factory.
Input Voltage High	The input voltage is too high - Check input voltage
Ram Fault	An error has been detected in RAM memory. Cycle power and if it returns consult factory.
Data Flash Fault	An error has been detected in the data area of memory. Consult factory.
Flash CRC Fault	An error has been detected in the code area of memory. Consult factory.
Heater Fault	An error was detected with the heater. Consult factory.

## LS2000 HART Menu Description

### More Transmitter Faults

Internal Voltage	An error was detected with an internal power supply. Consult factory.
Software Fault	A software fault was detected - Consult factory

### Transmitter Status

Warm-up	The device in in warm-up mode
Any Fault	The device has a fault
Config Change	A configuration change occurred
Temperature Over-Range	This fault is not supported
Output Loop Fixed	The 4-20 mA output is in the fixed mode
Modbus Unlocked	Configuration values can be changed with the Modbus interface.
Self Test Active	Indicates that the self test is active.

#### NOTES:

The default HART write protect password is: **OPECL**

Each time the HART handheld is disconnected from the Rx the password must be reentered to make any modifications.

The password must be entered and sent to the device to change between write protected and unprotected modes.

# APPENDIX G

## EAGLE QUANTUM PREMIER COMPATIBLE LS2000

### INSTALLATION AND WIRING

The Eagle Quantum Premier (EQP) version of the Model LS2000 uses the identical installation procedure, device location guidelines, and power supply requirements as described in the "Installation" section of this manual. Refer to the EQP version wiring diagram for specific wiring termination guidance.

An important difference in EQP applications is that LON network cabling will be routed both in and out from the EQP LS2000 enclosure, so this requirement should be anticipated and planned for during installation.

Table G-1—LON Maximum Cable Lengths

LON Cable NPLFA (Manufacturer and Part No.)*	Maximum Length**	
	Feet	Meters
Belden 3073F (Tray Rated)	6,500	2,000
Rockbestos Gardex Fieldbus		
1 Shielded Pair, 16 AWG, Type TC, p/n FB02016-001	6,500	2,000
1 Shielded Pair, 18 AWG, Type TC, p/n FB02018-001	6,500	2,000

Note: \*Use the same type of cable in each wiring segment between network extenders.

\*\*Maximum wire lengths represent the linear wire distance of LON communications wiring between network extenders.

Be sure that selected cable meets all job specifications, indoor, outdoor and direct burial.

If necessary, consult factory for further suggested cable types.

#### IMPORTANT

Det-Tronics recommends the use of shielded cable (required by ATEX) to prevent external electromagnetic interference from affecting field devices.

#### IMPORTANT

For best fault isolation performance, the maximum LON wiring length should not exceed 1600 feet (500 meters).

#### IMPORTANT

Be sure that selected cable meets all job specifications. The use of other cable types can degrade system operation. If necessary, consult factory for further suggested cable types.

## CONFIGURATION AND OPERATION

Configuration of the EQP LS2000 is accomplished using Det-Tronics Safety System Software (S<sup>3</sup>) that is running on the EQP Operator Interface Station (OIS).

The LS2000 should be configured as a Line-Of-Sight Gas Detector (LS2000).

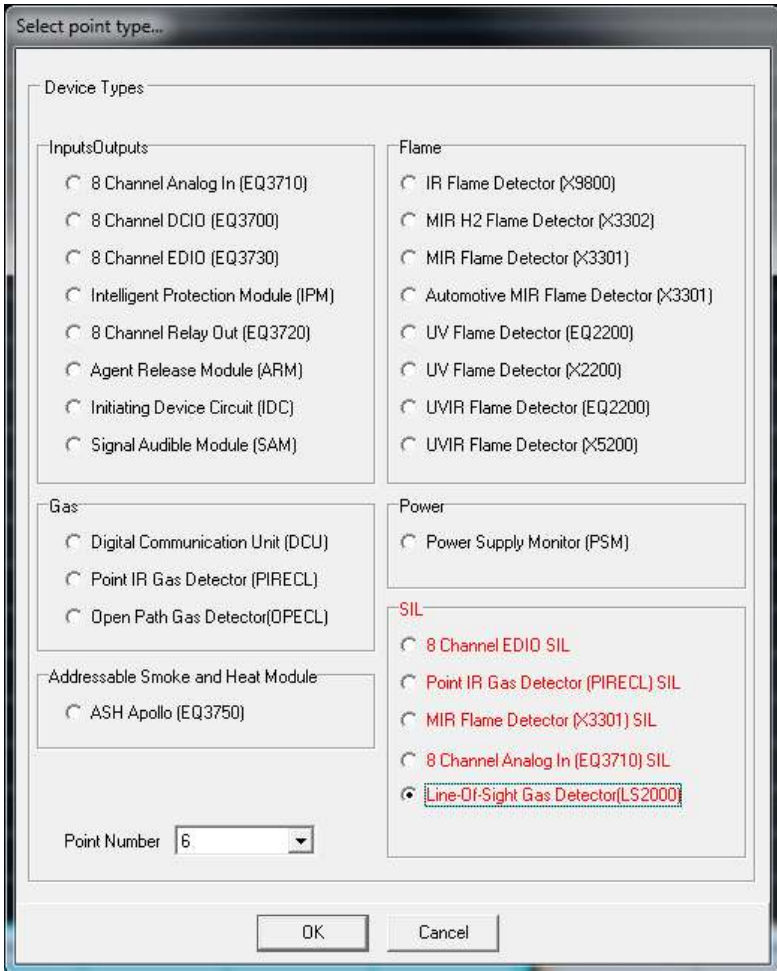

Supported gas types for the LS2000 include Methane (Default), Propane, and Butane.

The range for LS2000 high and low alarms is 0.5–3.0 LFL-m.

The beam block delay time can be set from 60–3600 seconds.

Alarms can be set for latching or non-latching operation.

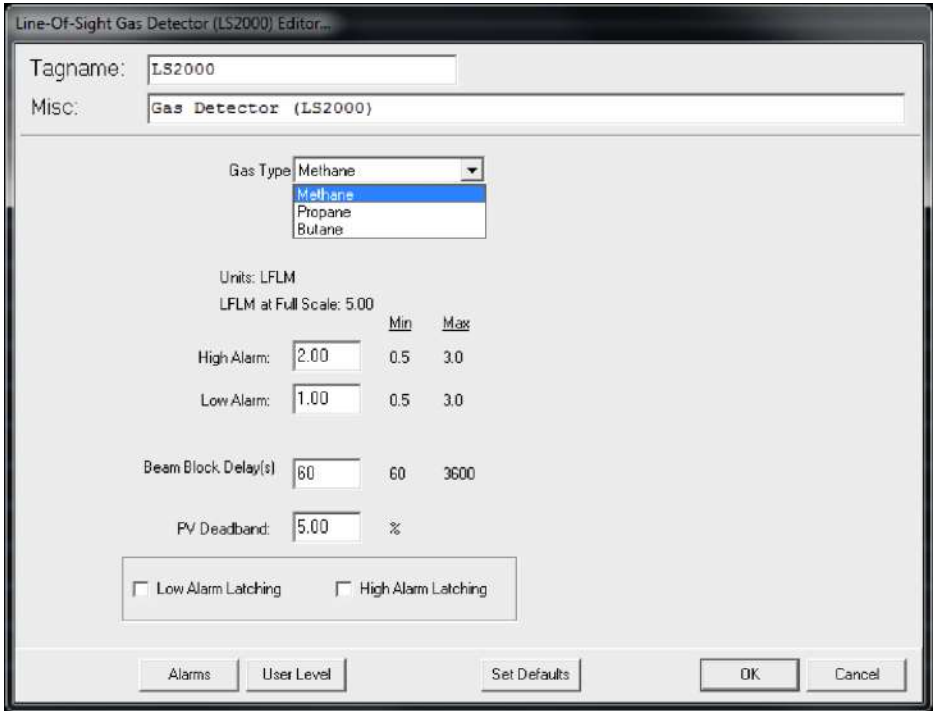

The real time clock in the LS2000 receiver is automatically set by the LON network approximately once per hour.

## ONBOARD HART INTERFACE

The on-board HART interface is functional on the EQP LS2000, however, it should not be used to select the gas type, alarm levels, or the beam block delay time because the LON will overwrite these values. All EQP device configuration should be performed using the S<sup>3</sup> program.

## MULTI-COLORED LED

Operation of the status indicating LED is identical to all other LS2000 versions.

## REMOTE CALIBRATION OPTION

Operation of the remote calibration option is identical to all other LS2000 versions.

## ANALOG OUTPUT

A 4–20 mA analog current output is not available with EQP LS2000.

## RS-485 COMMUNICATION

RS-485 Modbus RTU communication is available with EQP LS2000.

## CALIBRATION ROUTINE

The calibration procedure for the EQP LS2000 (zero calibration) is identical to all other LS2000 versions. Zero calibration can also be initiated by S<sup>3</sup>.

### NOTE

For complete information regarding installation, configuration or operation of the Eagle Quantum Premier system, refer to form 95-8533 (Eagle Quantum Premier hardware manual) or form 95-8560 (Safety System Software manual).

Table G-2—LS2000 Static Alarm Logic (Thresholds Programmed Using S<sup>3</sup> Configuration Software)

Field Device LS2000	Fire Alarm	High Gas Alarm	Low Gas Alarm	Trouble	Supervisory
High Alarm		X			
Low Alarm			X		

## SETTING NETWORK ADDRESSES

### Overview of Network Addresses

Each LS2000 IR gas detector on the EQP LON must be assigned a unique address. Addresses 1 to 4 are reserved for the EQP controller. Valid addresses for field devices including LS2000 gas detectors are from 5 to 250.

#### IMPORTANT

If the address is set to zero or an address above 250, the system will ignore the switch setting and the device.

#### IMPORTANT

The LS2000 sets the LON address only when power is applied to the device. Therefore, it is important to set the switches before applying power. If an address is ever changed, system power must be cycled before the new address will take effect.

The LON address is programmed by setting rocker switches on an 8 switch "DIP Switch" located within the LS2000 housing. The address number is binary encoded with each switch having a specific binary value with switch 1 being the LSB (Least Significant Bit). (See Figure G-1.) The device's LON address is equal to the added value of all closed rocker switches. All "Open" switches are ignored.

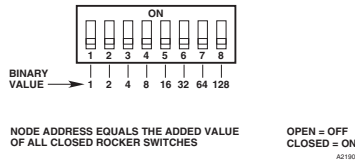

Figure G-1—LS2000 Address Switches

Example: for node No. 5, close rocker switches 1 and 3 (binary values 1 + 4); for node No. 25, close rocker switches 1, 4, and 5 (binary values 1 + 8 + 16).

#### NOTE

For convenience in setting LON address switches, a "Rocker Switch Table" is included in the EQP System manual (form 95-8533).

Do not assign duplicated addresses. Duplicated addresses are not automatically detected. Modules given the same address will use the number given and report to the controller using that address. The status word will show the latest update, which could be from any of the reporting modules using that address.

After setting address switches, record the address number and device type on the "Address Identification Chart" (form 95-8487). Post the chart in a convenient location near the Controller for future reference.

## LS2000 Address Switches

Address switches for LS2000 are located within the device enclosure. Refer to Figure G-2 for switch location.

### ⚠ WARNING

Disassembly of the LS2000 housing and removal of the front electronics module from the bulkhead is required to gain access to the network address switches. Power should be removed from the detector before disassembly. If disassembly is performed in a hazardous area, the area must be de-classified before starting disassembly.

### ⚠ WARNING

Disassembly of the LS2000 detector should only be performed with proper electrostatic discharge grounding protection. A controlled lab or shop setting is recommended for device programming.

The LS2000 detector contains semiconductor devices that are sensitive to electrostatic discharge (ESD). Damage caused by electrostatic discharge can be virtually eliminated if the equipment is handled only in a static safeguarded work area and protective measures against static electricity discharge are employed during the disassembly process. Since a static safeguarded work area is usually impractical in most field installations, handle the device by the housing, taking care not to touch electronic components or terminals. Use a wrist grounding strap or similar method at all times to control accidental ESD when disassembling, programming, or reassembling the LS2000 gas detector.

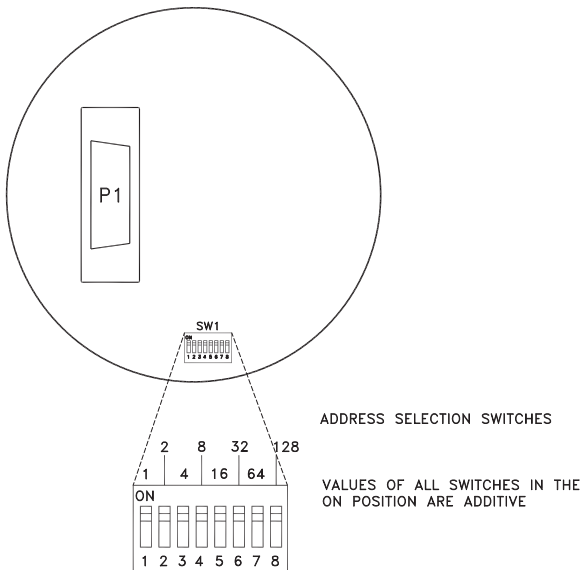

Figure G-2—Location of LS2000 Address Switches



## Switch Access Procedure

### NOTE

It is strongly recommended to document all LS2000 gas detector network addresses as well as the addresses of all other LON devices on the Address Identification Chart before disassembling and programming the LS2000 gas detectors.

Removal of the retaining ring and the front electronics module of the LS2000 IR gas detector from the bulkhead is required in order to gain access to the network address DIP switch.

1. Remove 24 Vdc power from the LS2000 detector.
2. Remove the retaining ring.
3. Carefully remove the electronics module by extracting it straight out from the bulkhead.
4. Set the network address switches.
5. Reinstall the electronics module by inserting it straight into the bulkhead, and then screw in retaining ring.

### NOTE

Take care to properly align the module's electrical connector with the bulkhead connector before attempting to fully insert the module. Failure to do so may result in damage to the module and/or bulkhead.

6. Apply power after all network addresses have been programmed and all field enclosures are properly installed.

## TYPICAL APPLICATIONS

Figure G-3 is a simplified drawing of a typical EQP system. This system includes an EQP Controller, DCIO, and various LON field devices.

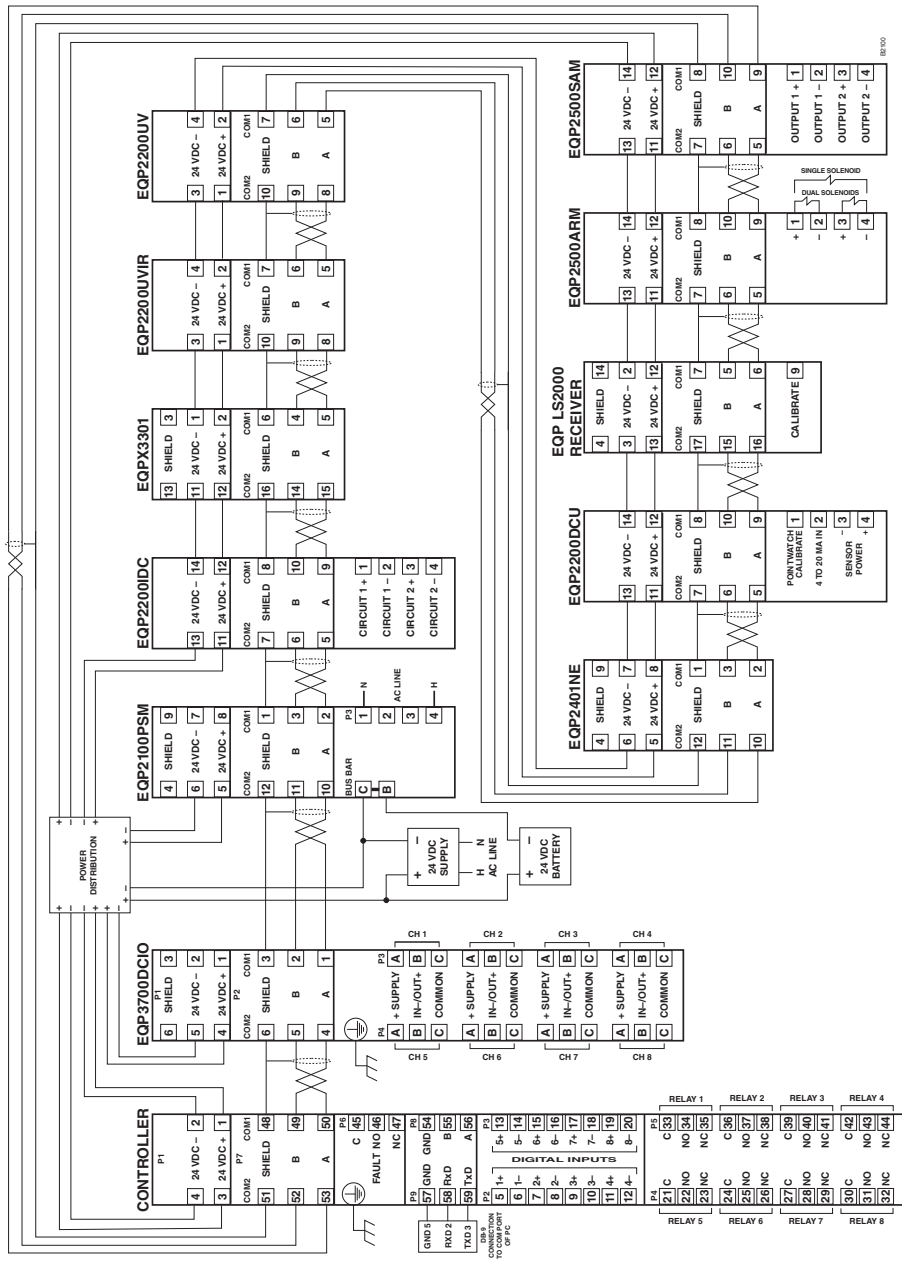

Figure G-3—A Typical System



95-8714



FlexSonic® Acoustic  
Leak Detector



X3301 Multispectrum  
IR Flame Detector



PointWatch Eclipse® IR  
Combustible Gas Detector



FlexVu® Universal Display  
with GT3000 Toxic Gas Detector



Eagle Quantum Premier®  
Safety System

Specifications subject to change without notice.

All trademarks are the property of their respective owners.

© 2020 Detector Electronics Corporation. All rights reserved.



Corporate Office  
6901 West 110<sup>th</sup> Street  
Minneapolis, MN 55438 USA  
[www.det-tronics.com](http://www.det-tronics.com)

Phone: +1 952.941.6665  
Toll-free: +1 800.765.3473  
Fax: 952.829.8750  
[det-tronics@carrier.com](mailto:det-tronics@carrier.com)