

# Syncro XT+

## Analogue Addressable Extinguishing Control Panel

### Product Manual

Man-1197 Issue 04 October 2019

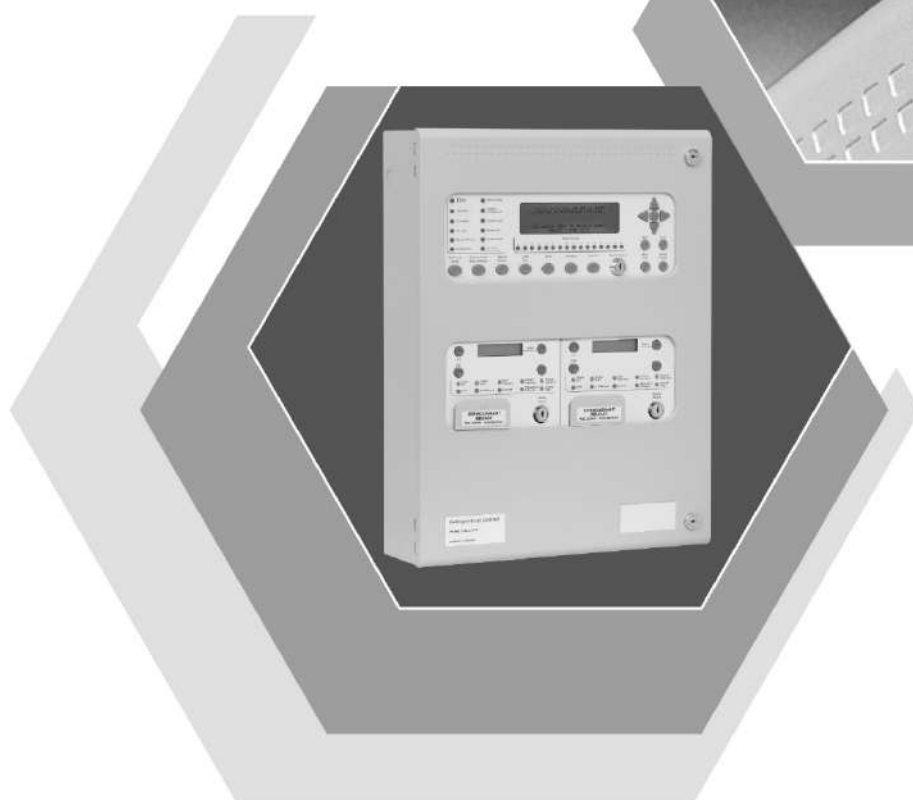
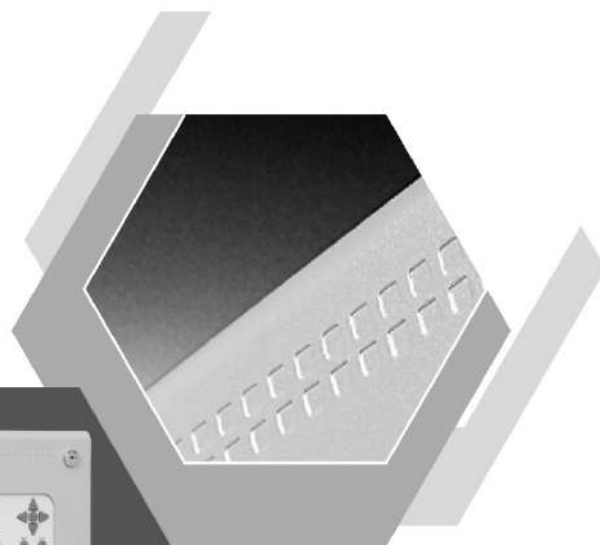

**1. Introduction ..... 6**

**2. Safety ..... 7**

**3. Technical specification ..... 7**

**3.1 Available models: ..... 8**

    3.2 *Compatible Status units*..... 8

**4. Installation..... 9**

    4.1 *Mounting the Cabinet*..... 9

    4.2 *Removing the fire detection equipment chassis* ..... 10

**5. Cabling ..... 11**

    5.1 *Cable Termination*..... 11

**6. Connecting to the panel..... 12**

**7. Front panel controls ..... 13**

    7.1 *CIE* ..... 13

    7.2 *ECD* ..... 15

        7.2.1 Access level 2..... 15

        7.2.2 Disable extinguishant release outputs. .... 15

        7.2.3 Disable Manual release ..... 15

        7.2.4 Disable Stage 1 output ..... 16

        7.2.5 Disable Stage 2 output ..... 16

        7.2.6 Disable Released output ..... 16

        7.2.7 Disable Extract output ..... 16

        7.2.8 Turn on Extract output ..... 16

        7.2.9 Select Reserve Solenoid Output (Configuration Option) ..... 16

        7.2.10 Access level 3..... 17

**8. Powering and configuring the panel ..... 17**

    ..... 17

    8.1 *Configuration Data - Write Enable Switch*..... 18

    8.2 *Configuring the Panel (Autolearn)* ..... 18

    8.3 *Configuring the Panel (from PC)* ..... 19

**9. Facilities Menus on CIE..... 21**

**10. Detection circuits ..... 21**

    10.1 *Fitting additional detection circuit (loop card)* ..... 22

**11. Loop sounders & Beacons..... 22**

    11.1 *Apollo*..... 23

    11.2 *Hochiki* ..... 23

        11.2.1 *Hochiki sounder Tone Settings*..... 23

**12. Panel Sounder circuits..... 25**

    12.1 *Stage one and stage two delays*..... 25

**13. Sounder controllers ..... 25**

**14. Relays..... 26**

14.1 CIE relays.....	26
14.2 ECD module relays.....	26
<b>15. Inputs .....</b>	<b>26</b>
15.1 CIE inputs.....	26
15.2 ECD inputs.....	26
<b>16. I/O serial busses.....</b>	<b>27</b>
16.1 CIE remote serial bus.....	27
16.1.1 - 16 channel I/O board .....	27
16.1.2 - 8 way relay board.....	28
16.1.3 - 6 way sounder board.....	28
16.1.4 - 4 way zone board .....	28
16.1.5 - Syncro View repeater unit.....	28
16.2 ECD remote serial bus.....	28
16.2.1 Adding new status units/ancillary boards .....	29
16.2.2 Removing status units or ancillary boards .....	29
<b>17. Power supply.....</b>	<b>30</b>
17.1 CIE Aux. 24V supply.....	30
17.2 CIE 24V OUT terminals.....	31
17.3 CIE Remote PSU.....	31
17.4 Battery capacity.....	31
<b>18. Programming via a PC.....</b>	<b>31</b>
18.1 Panel settings.....	31
18.1.1. Panel name .....	32
18.1.2. Panel address.....	32
18.1.3. Protocol .....	32
18.1.4. Number of loops .....	32
18.1.5. Default ringing mode.....	32
18.1.6 – Marine Mode.....	32
18.1.7. Access level code changes.....	32
18.1.8. Panel text .....	32
18.1.9. Panel Modem Fitted.....	32
18.1.10. Graphics System .....	33
18.1.11 – Loop Offset.....	33
18.1.12 – Apollo Intrinsically Safe Devices .....	33
18.1.13 – Zone Indicators.....	33
18.1.14 – Display Invert .....	33
18.1.15 – Any 2 devices to bypass delays – Def Ring Mode outputs only.....	33
18.1.16 – Resound for fire in same zone .....	33
18.1.17 – Resound for fire in other zone .....	33
18.1.18 – Hide Disablement Event for active delays .....	33
18.1.19 – Delays active on initialisation .....	33
18.1.20 – Ignore Global C&E Disablement.....	33
18.1.21. Day/Night times.....	33
18.1.22. Calibration time .....	34
18.1.23 Network Interface .....	34
18.1.24 Loop Sounder Options.....	34
18.2. Inputs .....	35
18.2.1. Fire action.....	35
18.2.2. Fault action .....	36
18.2.3. Pre-alarm action .....	36
18.2.4. Tech. alarm action (Technical alarm) .....	36
18.2.5. Evacuate action .....	36
18.2.6. Alert action .....	36
18.2.7. Security action .....	36
18.2.8. Silence alarm action .....	36
18.2.9. Reset action .....	36
18.2.10. Transparent action .....	36
18.2.11. Disablement action.....	36
18.2.12. Test mode action .....	37
18.3. Outputs .....	37

18.3.1. Evacuate Output .....	37
18.3.2. Def Ring Mode .....	38
18.3.3. Silenceable.....	38
18.3.4. Alert.....	38
18.3.5. Stage one delay.....	38
18.3.6. Stage two delay.....	38
18.3.7. Zoning.....	38
18.3.8. Location text .....	38
18.3.9. Tech alarm.....	38
18.3.10. Pre-alarm.....	38
<b>19. Cause and effect programming.....</b>	<b>39</b>
<b>20. Extinguishing module configuration .....</b>	<b>40</b>
20.1 Times tab .....	40
20.1.1 Discharge time .....	40
20.1.2 Release Delay.....	40
20.1.3 Release Duration .....	40
20.2 Disablements tab.....	40
20.2.1 Release Timer.....	40
20.2.2 Earth Fault monitoring.....	40
20.2.3 Fault Output.....	40
20.3 Settings tab .....	40
20.3.1 Stage Two Alarms .....	40
20.3.2 Release Indication.....	40
20.3.3 Release Pressure Switch Mode.....	41
20.3.4 Pre-Release Delay on Manual Activation.....	41
20.3.5 ROV Removed on Reset.....	41
20.3.6 Low Pressure Switch Mode .....	41
20.3.7 Language.....	41
20.3.8 Output Mode .....	41
20.3.9 Activation Mode .....	41
20.3.10 User Output Mode .....	41
<b>21. Networking.....</b>	<b>42</b>
<b>23. Panel Settings .....</b>	<b>43</b>
23.1. Write Enable switch.....	43
23.2. Contrast Adjust .....	43
23.3. Reset switch.....	43
23.4. W/DOG indicator.....	43
23.5. W/DOG REST switch.....	43
23.6. FUSE FAIL.....	43
23.7. Network address setting .....	44
23.8. Write Enable .....	44
23.9. Address .....	45
23.10. W/DOG REST switch.....	45
23.11. Proc Reset switch.....	45
23.12. Term Exting switch.....	45
23.13. Man release indicator.....	45
23.14. System Fuse indicator.....	45
23.15. System Fuse indicator.....	45
23.13. W/Dog tell tale indicator .....	45
<b>24. Panel specification summary .....</b>	<b>46</b>
24.1. Recommended cables.....	46
24.2. Sounder Load .....	46

24.3. Current consumption.....	46
24.4. Power supply - .....	46
24.5. Field devices .....	46
24.6 Relay ratings.....	46
24.7 Zones.....	46
24.8 Networking .....	46
24.9 Remote Control Inputs (see also Section 15).....	47
24.10 Auxiliary 24 Volt monitored output (see also Section 17.1).....	47
24.11 Fuse ratings .....	47
<b>25. Additional features .....</b>	<b>47</b>
25.1. Loop Data Test .....	47
25.2. Network Panel Menu Control.....	47
25.2.1. Network Disablements.....	47
25.2.2. View Device Details on other panels .....	48
25.2.3. Global System Time .....	48
25.3. Configuration Transfer over Network .....	48
25.4. Contamination Status.....	48
25.5. Analogue value transfer.....	48
<b>26. Maintenance .....</b>	<b>48</b>
<b>Appendix A – EN54 Configuration Requirements .....</b>	<b>49</b>
Section 7 – Fire Alarm Condition .....	49
Section 7.1.4 .....	49
Section 7.2.c / 7.4 / 8.2.1.c / 8.6.....	49
Section 7.6.1.....	49
Section 7.8.....	49
Section 7.9.....	49
Section 7.11 .....	49
Section 7.11.a .....	49
Section 7.11.d .....	49
Section 7.12.3 – Type C Dependency Programming.....	49
Section 8 – Fault Warning Condition .....	49
Section 8.2.4.c .....	49
Section 8.8.....	49
Section 9 – Disabled Condition.....	49
Section 9.1.2.....	49
Section 9.1.4.....	49
Section 10 – Test Condition.....	49
Section 10.1.b .....	49
Section 12.5 – Integrity of Transmission Paths.....	50
Section 12.5.2 .....	50
Section 12.6 – Accessibility of indications and controls.....	50
Section 12.6.6 .....	50

## 1. Introduction

The **Syncro XT+** is a combined Control and Indicating Equipment/ Extinguishing Control and Delay (CIE/ECD) analogue addressable control panel with 16 zonal LED indicators and is available in models with either 1 or 2 detection loops. It supports Apollo and Hochiki ESP protocol.

Models are available with up to four integrated extinguishing modules. Remote extinguishing modules may also be fitted up to a maximum of 32 extinguishing modules per system.

Syncro XT+ also supports loop-powered sounders, call points and I/O modules for the aforementioned protocols.

Any number of devices can be allocated to any zone ensuring that any system configuration can be easily accommodated.

Syncro XT+ panels may be networked to other Syncro XT+ panels, Syncro AS panels and Syncro panels with up to 64 nodes.

**NOTE:** The Syncro and Syncro AS panels must have the same firmware installed as the Syncro XT+ panel, to ensure full compatibility. It may be necessary to update the firmware on the Syncro/ Syncro AS panels to achieve this.

To ensure that the system is installed and commissioned with the minimum of trouble, it should be carefully planned before the installation is begun.

This involves allocating an address to each device and allocating a message of up to 40 characters (including spaces) to each address to assist in the location of the devices.

Devices should then be grouped into zones and appropriate zones allocated to extinguishing modules in accordance with the appropriate fire detection systems design standards and building plans.

The control panel can be configured using the switches on the front as described in the menu descriptions in this manual or more comprehensively, using the Loop Explorer 2, PC configuration utility and download lead which is available as a separate item.

In addition to its extinguishing control functions, the **Syncro XT+** control panel offers an extensive list of features and options for the control and monitoring of plant, equipment and sounders, which can be configured via the Loop Explorer 2, PC configuration programme or the front panel controls.

In addition to the EN54-2 and EN12094-1 options with requirements below, the panel supports facilities such as Day/Night sensitivity changes and cause & effect configuration to enable more comprehensive systems to be implemented.

The range of compatible devices includes optical and ionisation smoke sensors, heat sensors, multi-sensors, switch monitors, sounders, relay modules, solenoids, explosive actuators, status indicator units and bell controllers. Interfaces to conventional detection systems can also be catered for using conventional zone-monitoring devices or conventional zone I/O boards connected to the ancillary serial bus.

Each loop offers an addressing range from 1 to 127 (Hochiki) or 1 - 126 (Apollo). Devices such as the switch monitors and bell controllers have "Sub-addresses" in addition to their main address. Each panel can be configured to recognise up to 800 sub-addresses.

A switch monitor for example, may have a main address of 123, input 1 a sub-address 123.1 and input 2 a sub-address 123.2. (Three addresses from 800 available).

The sub-addresses can be treated as if they were individual addresses i.e. each can be allocated to any zone, given an individual address message and be operated by or contribute to different cause and effect tables.

Although unlikely to be exceeded, the maximum number of sub-addresses available should be taken into consideration when designing systems that contain large numbers of I/O units.

**Important:** This control panel should be used only with compatible fire system components. I.e. Apollo Series 90/XP95/ Discovery Protocol or Hochiki ESP Protocol.

The control panel has the following options with requirements as defined in BS EN54-2: 1997.

- 1) Fault signals from points (clause 8.3)
- 2) Delay of the actioning of inputs and outputs (clause 7.11)
- 3) Disablement of each address point (clause 9.5)
- 4) Test condition (clause 10.1 to 10.3)
- 5) Control of Fire alarm devices (clause 7.8)
- 6) Co-incidence detection (clause 7.12)

The control panel has the following options with requirements as defined in BS EN12094-1:

- 1) Delay of extinguishing signal of up to 60 seconds. EN12094-1 Section 4.17
- 2) Signal representing the flow of extinguishing agent to indicate the released condition. EN12094-1 Section 4.18
- 3) Monitoring of the status of components by way of a low pressure switch input. EN12094-1 Section 4.19
- 4) Emergency hold device to enable the extinguishant delay time to be extended. EN12094-1 Section 4.20
- 5) Control of flooding time to deactivate the releasing output after a set period of time. EN12094-1 Section 4.21
- 6) Manual only mode to disable the release of extinguishant via automatic detection devices. EN12094-1 Section 4.23
- 7) Triggering of equipment outside the system by way of first and second stage contacts, extract fan output etc. EN12094-1 Section 4.26
- 8) Activation of alarm devices with different signals to indicate pre- discharge and released warnings using different sounds. EN12094-1 Section 4.30

- 9) Emergency Abort device to inhibit the extinguishing signal until the emergency abort device has been de-activated and the panel has been reset. EN12094-1 Section 4.27  
 10) Extinguishing signals to spare cylinders. EN12094-1 section 4.25

**2. Safety**

Suppliers of articles for use at work are required to ensure as reasonably as is practical that the article will be safe and without risk to health when properly used.

An article is not regarded as properly used if it is used 'without regard to any relevant information or advice' relating to its use made available by the supplier.

This product should be installed, commissioned and maintained by trained service personnel in accordance with the following:

- (i) IEE regulations for electrical equipment in buildings
- (ii) Local Codes of practice
- (iii) Statutory requirements
- (iv) Any instructions specifically advised by the manufacturer

You are therefore requested to take such steps as are necessary to ensure that you make any appropriate information about this product available to anyone concerned with its use

This equipment is designed to operate from 230V 50Hz mains supplies and is of class 1 construction. As such it **must** be connected to a protective earthing conductor in the fixed wiring of the installation. A readily accessible double pole disconnect device with a disconnect air gap of at least 3mm and conforming to EN 60950, shall be incorporated in the fixed wiring.

**Failure to ensure that all conductive accessible parts of this equipment are adequately bonded to the protective earth will render the equipment unsafe.**

This control panel is environmental class A and is designed for indoor use only at temperatures between -5°C (+/- 3) and +40°C (+/- 2) and with a maximum relative humidity of 95%.

The IP rating for the enclosure is IP30.

Operation outside of these limits may render the equipment unsafe.

**3. Technical specification**

Mains supply	230V AC, 50Hz +10% -15% (100 Watts maximum)
Mains supply fuse	F3A 250V TD 20mm. (Replace only with a fuses of the same type).
Power supply rating I <sub>max a</sub>	1.7A
Power supply rating I <sub>max b</sub>	5A
Operating voltage	18 to 30 volts DC
Battery charging circuit impedance R <sub>imax</sub>	1.0R
Minimum output current for correct operation I <sub>min</sub>	10 milliamps
Maximum ripple current	1.5 +/- 0.3 Volts
Battery type	Yuasa NP 7Ah or NP 12Ah, Flame retardant UL94:V-0
Battery charge voltage	27.6V DC nominal (temperature compensated)
Battery charge current	1.25A max
Maximum current draw from batteries	7 Amps
Aux 24V output rating (CIE)	100 milliamps maximum load (fused at 500 milliamps)
Aux 24V output rating (ECD)	100 milliamps maximum load (fused at 500 milliamps)
Sounder output rating (CIE two outputs)	500 milliamps each (fused at 1A)
Sounder output rating (ECD two outputs)	500 milliamps each (fused at 1A)
Relay contacts	30V DC, 1 Amp maximum
Detection loop current	400 milliamps maximum
Extinguishant release outputs (2 per extinguishing module)	18 to 30V DC. Fused at 1 Amp
Extinguishant release delay	Adjustable 0 to 60 seconds (+/- 10%)
Extinguishant release duration	Adjustable 60 to 300 seconds
ECD Monitored inputs normal threshold (Allowable EOL)	10K ohm to 2K ohm
ECD Monitored inputs alarm threshold	2K ohms to 150 ohms +/- 5%
ECD Monitored inputs Short circuit threshold	140 ohms to 0 ohms +/- 5%
ECD Status unit/Ancillary board connection	Two wire RS485 connection (EIA-485 specification)
Status unit/Ancillary board power	24V (3 maximum per ECD module)

### 3.1 Available models:

The range of available models is as follows:

A31161M3 – Apollo protocol, single loop, single area extinguishant control panel  
A32161M3– Apollo protocol, two loop, single area extinguishant control panel  
A31162M3– Apollo protocol, single loop, two area extinguishant control panel  
A32162M3– Apollo protocol, two loop, two area extinguishant control panel  
A31163M4– Apollo protocol, single loop, three area extinguishant control panel  
A32163M4– Apollo protocol, two loop, three area extinguishant control panel  
A31164M4– Apollo protocol, single loop, four area extinguishant control panel  
A32164M4– Apollo protocol, two loop, four area extinguishant control panel

H31161M3 – Hochiki protocol, single loop, single area extinguishant control panel  
H32161M3– Hochiki protocol, two loop, single area extinguishant control panel  
H31162M3– Hochiki protocol, single loop, two area extinguishant control panel  
H32162M3– Hochiki protocol, two loop, two area extinguishant control panel  
H31163M4– Hochiki protocol, single loop, three area extinguishant control panel  
H32163M4– Hochiki protocol, two loop, three area extinguishant control panel  
H31164M4– Hochiki protocol, single loop, four area extinguishant control panel  
H32164M4– Hochiki protocol, two loop, four area extinguishant control panel

K31001H2 – Remote, single area coincidence unit

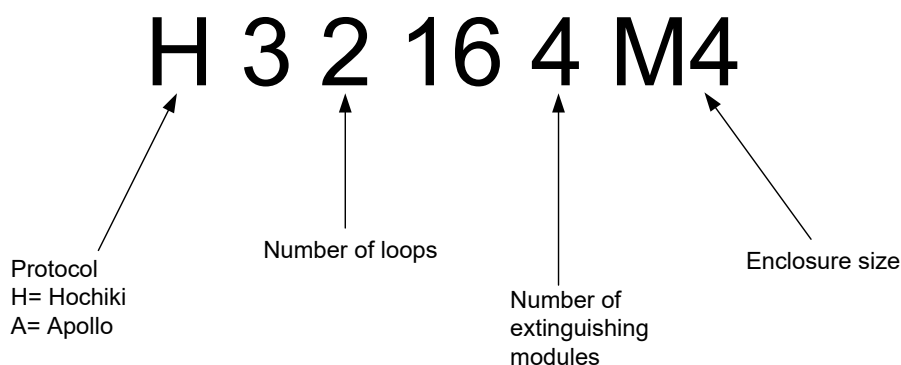

### 3.2 Compatible Status units

K911000M8	6 lamp status unit surface
K911000F8	6 lamp status unit flush
K911100M8	6 lamp status unit with mode select keyswitch surface
K911100F8	6 lamp status unit with mode select keyswitch flush
K911010M8	6 lamp status unit with manual release surface
K911010F8	6 lamp status unit with manual release flush
K911110M8	6 lamp status unit with mode select keyswitch and manual release surface
K911110F8	6 lamp status unit with mode select keyswitch and manual release flush
W911000W8	IP65 - 6 lamp status unit surface
W911100W8	IP65 - 6 lamp status unit with mode select keyswitch surface
W911110W8	IP65 - 6 lamp status unit with mode select keyswitch and manual release surface

**NOTE:** 10 lamp status units (models K911113M8, K911113F8 and W911113W8) are not compatible with Syncro XT+ panels.



#### 4. Installation

Installation of the panel should be carried out by qualified personnel only. The electronic components within the panel are vulnerable to physical damage and damage by electrostatic discharges.

**It is advisable to wear a wrist strap designed to prevent the build-up of static charges within the body, before handling any electronic circuit boards.**

Never insert or remove boards or components with the power on.

##### 4.1 Mounting the Cabinet

The site chosen for the location of the panel should be clean and dry and not subject to shock or vibration. The temperature should be in the range  $-5^{\circ}$  to  $+35^{\circ}$  C, the humidity should not exceed 95%.

Remove knockouts from the top and or back of the box in the positions at which cables will enter.

Using the box as a template, mark the position of the top fixing hole, ensuring that the wall is flat at the chosen location. The top fixing is a keyhole slot and fitting a screw here and hanging the box first will assist in marking the remaining fixing points.

Screws or bolts of a minimum of 5mm diameter and 40mm long must be used to mount the enclosure in all four mounting positions.

After the box is firmly fixed, remove any knockout blanks and dust or swarf caused by drilling and fixing the box.

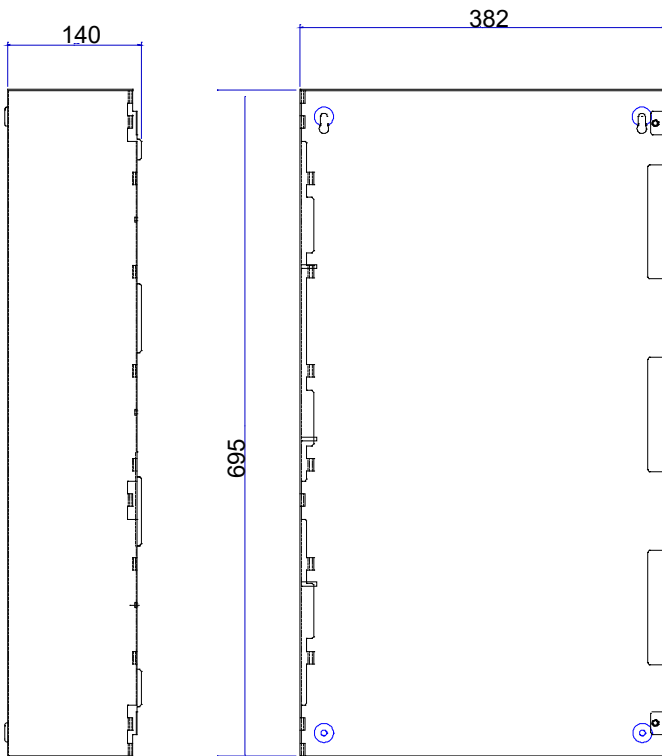

**M4 enclosure dimensions**

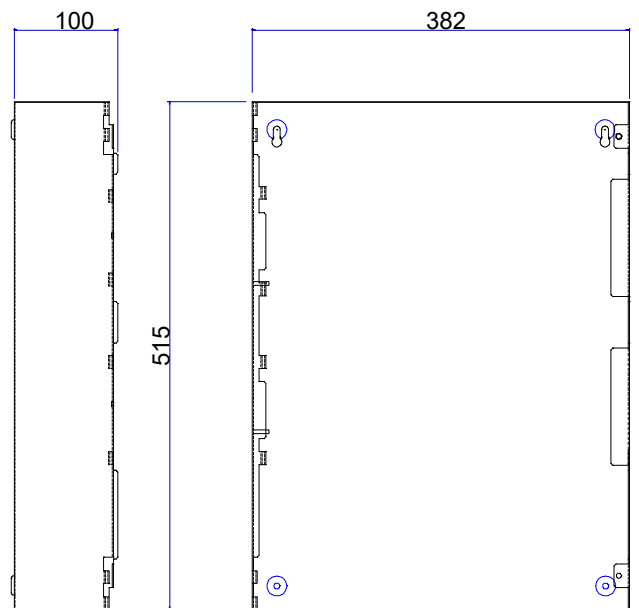

**M3 enclosure dimensions**

## 4.2 Removing the fire detection equipment chassis

Open the control panel lid using the two 801 lock keys.

Before the CIE chassis can be removed it will be necessary to disconnect the power connector terminal block on the left hand side of the PCB. This is fitted on pins and can be pulled towards you to remove it.

Also remove the red, black and grey wires from the terminals marked REMOTE PSU.

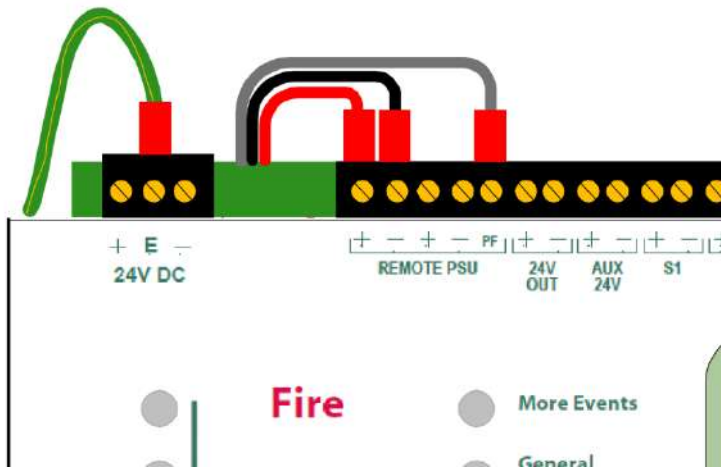

The chassis is held in place by two screws. Undo the two screws and lift the chassis gently away from the box towards you.

With the chassis removed, there is much more room inside the panel for making off and dressing cables.

When cabling work is complete, the chassis can be re-fitted with the two screws and the terminal block plugged back onto the pins on the board.

**The extinguishant module chassis should not be removed.**

## 5. Cabling

It is advisable to fit all cable glands and cables before re-fitting the outer cover and plate/circuit board assembly. Cables should be brought into the cabinet using the knockouts provided and where necessary, using couplers to maximise the space within the enclosure. Use the knockouts closest to the terminating position for each cable, to ensure cable length within the enclosure is kept to a minimum.

Ensure that only the numbers of knockouts are removed to meet the cable termination requirements, as any additional apertures in the enclosure will compromise the IP30 ingress protection requirements required by EN54-2 and EN10294-1.

Brass inlet bushings or cable glands should be used to maintain insulation and to ensure EMC compliance to the requirements of EN54-2 and EN12094-1.

The screen or drain wires should be bonded to earth via the cable gland fixing nut and shake proof washers.

The maximum size of cable, which can be terminated, is 2.5<sup>2</sup> mm.

The communications protocols are highly immune to noise but sensible segregation from known noise generating sources such as mains cables is recommended. A minimum of 50mm segregation between mains and other cables is recommended.

Detection circuit cable size and type is dependent on the number and type of devices used and should be calculated for each installation. Cable length calculators are available for both Hochiki ESP and Apollo protocols.

Cabling for sounder and extinguishing circuits should be sized according to load and cable length but 1.5mm<sup>2</sup> should suffice in the majority of cases.

The control panel requires a 230V AC supply, which should be derived from a separate fused spur, labelled "**Fire Alarm - Do Not Switch Off**".

The mains supply must include an earth conductor connected to the fixed installation earthing system of the building.

This equipment relies on the building installation for protection and requires a 5-amp protection device. The mains supply should use cable with a minimum cross section of 1.5mm<sup>2</sup>.

### 5.1 Cable Termination

Drain wires need to be terminated at the brass cable gland to ensure EMC compliance to the requirements of EN54-2 and EN12094-1.

To ensure good earth bonding at entry to the panel enclosure, it is recommended that the cable drain wires are terminated using Prysmian AXT brass cable glands. These glands have a slotted fixing thread, which allows the drain wire to be clamped between the gland fixing nut and panel enclosure. To ensure that a good earth bonding between the drain wire and panel case, a 20mm shake proof washer should be used, as shown in the termination diagram below

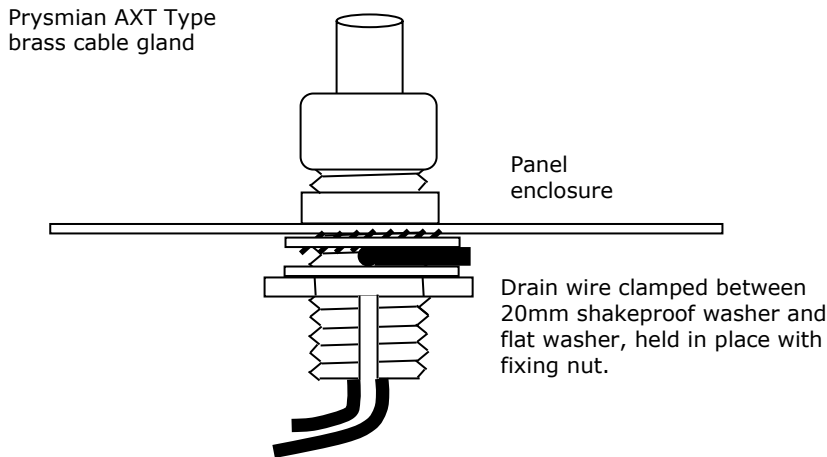

## 6. Connecting to the panel

All connections to the panel are via 5mm pitch, 2.5mm<sup>2</sup> capacity, spring leaf terminal blocks. Care should be taken to use the correct sized terminal screwdriver and not to over tighten the terminals.

If stranded cables are used then care should be taken to ensure that all strands are contained in the terminal and that there are not any loose strands which may cause short circuits to other terminals or cables.

The mains connection should enter the enclosure via a knockout as near to the mains terminal block as possible and should be segregated from all other wiring. Mains connection cables should be kept short and be secured together with a cable tie near the mains terminal block to minimise the danger of them shorting to other parts of the equipment if they become disconnected.

The mains terminal block contains a F3A L250V fuse and must be replaced only with a fuse of the same type.

To avoid the possibility of a confusing array of fault conditions, it is best to connect the system gradually so that faults can be cleared on one circuit before connecting another.

Polarity must be observed carefully on any terminals with + or - markings and end of line devices must be fitted to all circuits which connect to terminals that have had the supplied, end of line devices removed.

All wiring should be checked carefully before applying power to the control panel.

## Connections to the CIE

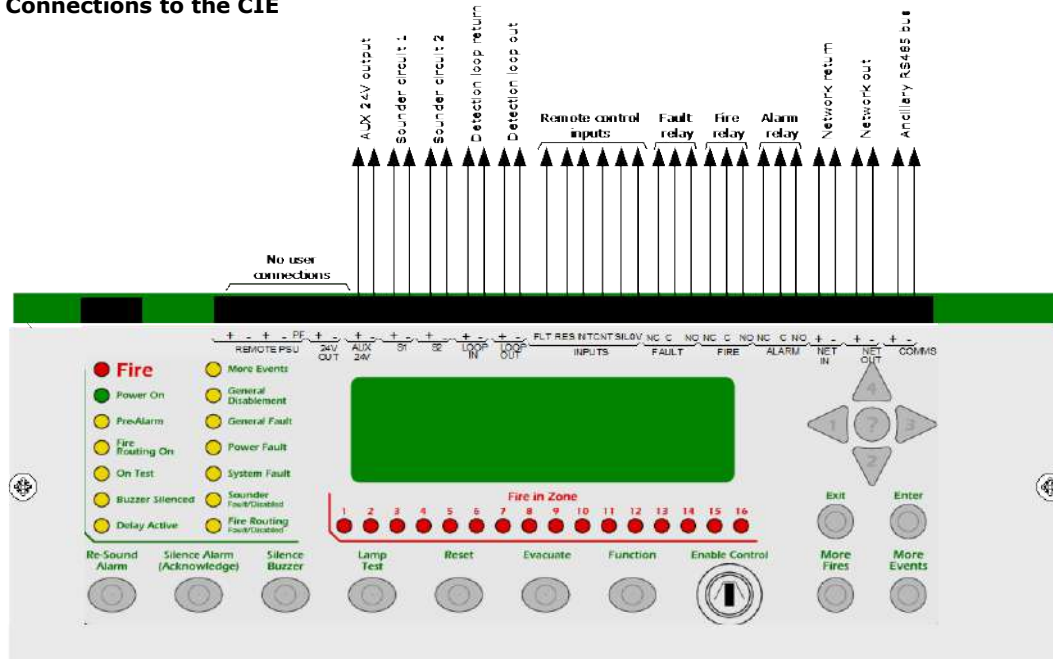

## Connections to the ECD

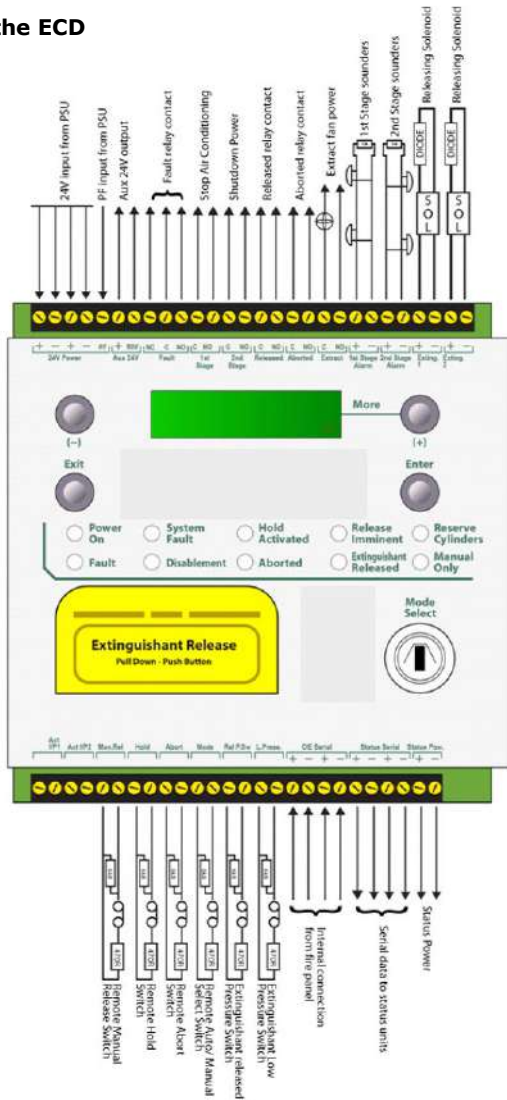

## 7. Front panel controls

### 7.1 CIE

The front panel contains controls for operating and programming the panel.

The lamp test and silence buzzer buttons can be operated at any time. (Access level 1)

The More Fires and More Events buttons can be operated at any time when there are more events than can be displayed on the screen. (Access level 1).

The menu navigation buttons (1, 2, 3 and 4) can be used to enter the password to Access level 2 (password 2222) which then enables the Silence Alarm (Acknowledge), Re-sound Alarm, Reset, Evacuate and Function buttons. This also gives the user access to the Access level 2 menu facilities such as disabling and testing parts of the system.

Access level 2 can also be entered by operation of the Enable control keyswitch on models that have this switch fitted.

The internal panel buzzer will "beep" whenever a button is pressed.

The Help (?) button offers additional information relating to the current status of the control panel. For example, if the panel is in an alarm or fault condition then advice on the recommended action will be displayed when the ? button is pressed or if a menu function is being accessed then help relating to that function will be displayed when the ? button is pressed.

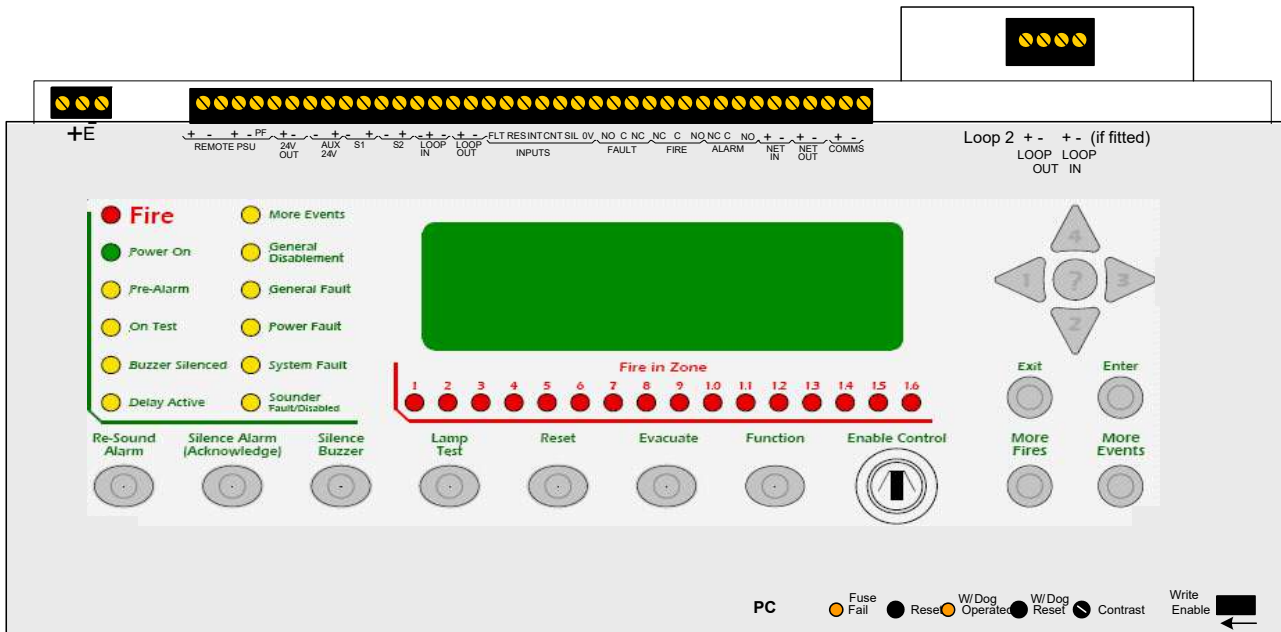

With the lid of the control open, more controls are revealed. These controls are strictly for service personnel and should not be operated by the user under any circumstances. Opening the front cover also gives access to the PC connection port for programming.

If the processor stops running or re-boots for any reason, the watchdog indicator (W/Dog Operated) will illuminate as a record of this event. This indicator can only be reset by operating the watchdog reset switch (W/Dog Reset).

It is necessary under some circumstances (after a firmware upgrade for instance) to re-start the processors in the panel. A reset switch is provided for this purpose labelled Reset.

A display contrast adjust control is provided which can be adjusted to suit the lighting conditions at the installed panel. This is a rotary control and can be adjusted with a small terminal screwdriver.

In order to change the configuration of the control panel, the configuration memory must be enabled. This is done by carefully sliding the Write Enable slide switch using a small screwdriver from its normal, right hand position, to the left as indicated by the arrow beneath it.

A warning is displayed on the LCD when the write enable switch is in the enabled position to prevent it from being inadvertently being left in this position. This warning can be reset after the switch has been returned to its normal position by pressing the front panel Reset button. If not reset, the warning will time out a short while after the Write Enable switch is returned to the right hand position.

All of the access level 3 controls are recessed to avoid accidental operation but all can be accessed using a small, terminal screwdriver or similar tool.

## 7.2 ECD

Controls on the ECD part are limited to a Manual release control behind a protective flap, a keyswitch to change the mode from Automatic & Manual to Manual only and menu navigation buttons. The menu navigation buttons are available at access level 2, allow items related to the ECD to be disabled and enabled, control of the extract output and selection of reserve extinguishing outputs if provided for.

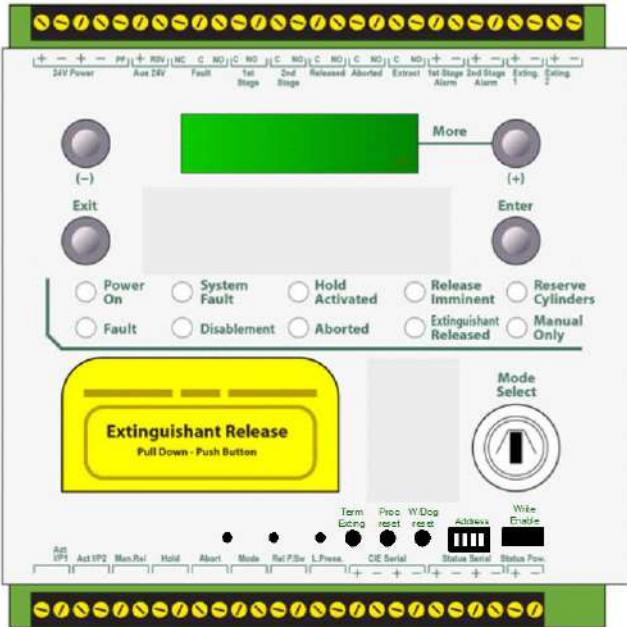

Access Level 2 options are as follows:

### 7.2.1 Access level 2

With the Enable Control keyswitch on the CIE operated, all extinguishant modules will display:

```
ACCESS LEVEL 2 ►
ENTER FOR MENU
```

### 7.2.2 Disable extinguishant release outputs.

To disable both of the extinguishant release outputs, press the + button on the module while at access level 2. The display will show:

```
DISABLE
EXTING. RELEASE ?
```

Press the Enter button to select this function. The display will show:

```
ENABLE
EXTING. RELEASE ?
```

The yellow disabled LED on the module that has been disabled will be lit.

Turn the Enable keyswitch off to leave the disablement active. To re-enable the extinguishant outputs repeat the procedure above.

### 7.2.3 Disable Manual release

To disable all Manual release inputs (front panel mounted and remotely connected), press the + button on the module while at access level 2 until the module displays:

```
DISABLE
MANUAL RELEASE ?
```

Press the Enter button to select this function. The display will show:

```
ENABLE
MANUAL RELEASE ?
```

The yellow disabled LED on the module that has been disabled will be lit.

Turn the Enable keyswitch off to leave the disablement active. To re-enable the manual release facility repeat the procedure above.

#### 7.2.4 Disable Stage 1 output

To disable the 1<sup>st</sup> Stage relay output, press the + button on the module while at access level 2 until the display shows:

DISABLE  
STAGE 1 OUTPUT ?      Press the Enter button to select this function. The display will show:

ENABLE  
STAGE 1 OUTPUT ?      The yellow disabled LED on the module that has been disabled  
will be lit.

Turn the Enable keyswitch off to leave the disablement active. To re-enable the Stage 1 relay output repeat the procedure above.

#### 7.2.5 Disable Stage 2 output

To disable the 2<sup>nd</sup> Stage relay output, press the + button on the module while at access level 2 until the display shows:

DISABLE  
STAGE 2 OUTPUT ?      Press the Enter button to select this function. The display will show:

ENABLE  
STAGE 2 OUTPUT ?      The yellow disabled LED on the module that has been disabled  
will be lit.

Turn the Enable keyswitch off to leave the disablement active. To re-enable the Stage 2 relay output repeat the procedure above.

#### 7.2.6 Disable Released output

To disable the Released relay output, press the + button on the module while at access level 2 until the display shows:

DISABLE  
RELEASED OUTPUT ?      Press the Enter button to select this function. The display will show:

ENABLE  
RELEASED OUTPUT ?      The yellow disabled LED on the module that has been disabled  
will be lit.

Turn the Enable keyswitch off to leave the disablement active. To re-enable the Released relay output repeat the procedure above.

#### 7.2.7 Disable Extract output

To disable Extract relay output, press the + button on the module while at access level 2 until the display shows:

DISABLE  
EXTRACT OUTPUT ?      Press the Enter button to select this function. The display will show:

ENABLE  
EXTRACT OUTPUT ?      The yellow disabled LED on the module that has been disabled  
will be lit.

Turn the Enable keyswitch off to leave the disablement active. To re-enable the Extract relay output repeat the procedure above.

#### 7.2.8 Turn on Extract output

To turn on the extract relay output, press the - button on the module while at access level 2 until the display shows:

TURN ON  
EXTRACT OUTPUT              Press the Enter button to select this function. The display will show:

TURN OFF  
EXTRACT OUTPUT ?      The yellow disabled LED on the module that has been disabled  
will be lit.

Turn the Enable keyswitch off to leave the Extract output active. To turn off the Extract output, repeat the procedure above. Note: the extract output does not turn off when the module is reset.

#### 7.2.9 Select Reserve Solenoid Output (Configuration Option)

If the extinguishing module is configured for Main/Reserve solenoid operation then an additional menu option is given to select which output is used.

To turn on the Reserve Solenoid output, press the + button on the module while at access level 2 until the display shows:

SELECT RESERVE  
EXTING. OUTPUT              Press the Enter button to select this function. The display will show:

SELECT MAIN  
EXTING. OUTPUT ?              The yellow Reserve Cylinders LED indicator on the module will be lit.

Turn the Enable keyswitch off to leave the Reserve solenoid output active. To revert to the Main solenoid output, repeat the procedure above.

Note: This menu option is not shown if the panel is configured to Common Solenoid mode.



### 7.2.10 Access level 3

The ECD has limited options at access level 3, the main use being to set the extinguishing monitoring level.

The number of updates to the modules configuration is also displayed at access level 3.

To change the monitoring level of the extinguishing outputs it is necessary to enter access level 3.

To do this, carefully slide the Write Enable switch to the left. The switch should be operated with minimum force.

Turn the Enable controls keyswitch (or enter the four digit access level 2 pass code) on the CIE part of the panel. The number of updates to the modules configuration is displayed when the ECD is at access level 3 as shown below.

The opening of the enclosure door is also classified as access level 3. Here you will find the product rating label.

```
AL3 UPDATES = XX  
ENTER FOR MENU
```

The XX here shows the number of configuration updates that the module has had. Press the ENTER button and then the + button until the LCD displays:

```
EXTING. O/P 1  
LEVEL = XXX
```

The XXX displayed here is the previous (factory) level to which the monitoring level had been set.

Press the ENTER button. The LCD will now show:

```
EXTING. O/P 1  
LEVEL = XXX ?
```

The XXX shown here is the current monitoring level detected on the extinguishing output. Press the ENTER button to learn the new monitoring level if the extinguishing circuit is correctly terminated. The circuit characteristics are then learned by the panel and a fault will be announced if these change.

Press the + button to set the monitoring level for output 2 in the same way if it is being used, otherwise switch the write enable slide switch to the right (off) position and check that an open or short circuit fault on the extinguishing output(s) is detected and shown on the control panel.

## 8. Powering and configuring the panel

Never connect batteries before applying mains power first.

Ensure that the panel is free from swarf, wire ends, knockout blanks and any other debris

Ensure that all cable connections to loops, sounder circuits and other inputs or outputs being used are correct and that the wiring is formed tidily away from the surface of the circuit board before applying power.

The panel requires sealed lead acid batteries. The batteries should be placed in the bottom of the box with the terminals facing up and facing each other.

Batteries can be dangerous. Do not short the battery terminals to the enclosure or mounting plate. The polarity of the battery connection should be checked carefully before proceeding.

After applying mains power, connect the batteries together first by fitting the battery link to the battery terminals nearest the back of the enclosure.

Connect the red battery lead to the red (+) terminal of the left hand battery nearest the front of the enclosure and the black battery lead to the black (-) terminal of the right hand battery nearest the front of the enclosure.

### Caution:

**RISK OF EXPLOSION IF BATTERY IS REPLACED BY AN INCORRECT TYPE.  
DISPOSE OF USED BATTERIES ACCORDING TO THE INSTRUCTIONS**

### 8.1 Configuration Data - Write Enable Switch

Panels have a memory "Write Enable" switch fitted on the CIE part. This switch is used to physically prevent the configuration memory contents from being changed. Before making any changes to the panel configuration, it is necessary to ensure that this switch is in the "Enable" position. The "Enable" position is with the switch actuator set to the right in the direction of the arrow under the switch. When left in the "Enable" position, a notification message will be given on the Syncro AS display. This warning message will disappear a short while after the switch has been turned off or can be cancelled immediately by operating the front panel Reset button.

**It will not be possible to perform the Autolearn sequence or transfer a configuration into the panel from the PC (as described below) unless the configuration memory Write Enable switch is on.** It is also necessary to operate the write enable switch whenever any changes are made to the configuration memory using the Access Level 3 "Edit Configuration" or "Set Times" menu options via the front panel controls.

### 8.2 Configuring the Panel (Autolearn)

When supplied, the panel will contain a default configuration and when power is first applied the display will show:

```
***WARNING***  
  
WRITE ENABLE SWITCH IS OFF  
SET WRITE ENABLE AND RESET THE SYSTEM
```

CAREFULLY slide the write enable slide switch (located behind the aperture in the bottom right corner of the plate) to the left position using a small screwdriver, or similar tool. Then press the internal Reset switch that can be seen through the hole in the plate with a small terminal screwdriver or similar tool.

The display will then show:

```
RE-INITIALISING PANEL  
  
PLEASE WAIT...
```

Followed by

```
INITIALISING LOOPS, PLEASE WAIT  
  
LOOP      NUM. DEVICES      INIT. PROGRESS  
1         000              0%
```

Initialisation can take a few minutes to complete and the larger the number of devices on a loop the longer it takes. Panels fitted with Hochiki protocol will take significantly longer to initialise than those fitted with Apollo protocol.

At the end of the initialisation process, if there are no faults, and after the write enable switch has been CAREFULLY switched to the right position (using a small screwdriver or similar tool) the "normal" display will be shown as below.

```
13:05 Thursday 24 August 2006  
AUTO CONFIGURED PANEL  
  
USE ARROW KEYS TO ENABLE PANEL  
PRESS? FOR HELP
```

On a system, which has been Auto learned, inputs, outputs and field devices will be configured to the EN54-2 default settings. Some of these defaults may be altered at access level 3 on the control panel. All can be altered via the Loop Explorer 2 configuration programme.

It is quite common for mistakes to occur when addressing large numbers of devices and it is possible that some devices may have been set to the same address.

The control panel can detect devices that have been set to the same address and will announce a "Double address" fault if it finds any.

It is not possible for the control panel to tell which devices have been double addressed but to help find them, enter access level 2 by entering the code 2222 (or operating the key switch if fitted), go to the view devices option in the menu, select view devices by loop and make sure that all of the devices that are expected are listed.

If there is one double address fault and one device missing from the list of expected devices then it is fairly certain that the missing one is the one that has been addressed incorrectly.

It becomes a bit trickier when there are more than 2 devices with the same address or more than 1 double address but using the principle above it will be possible to find the errors by a process of elimination.

It is always much quicker and easier to commission a system which has been addressed correctly and extra care taken to fit devices with the correct address as per the installation plan will pay great dividends at the commissioning stage.

If a fairly heavily populated loop is disconnected from the panel, the panel will report all of the devices disconnected. Upon re-connection of the loop, the panel will find all of the devices again but it also has to run as a fire control panel, service other parts of the system and re-initialise the devices that have been detected. In the case of a large number of faults under these circumstances it is often quicker to get the system back to normal by re-starting the panel by pressing the Reset switch (located with the door open and to the right of the Fuse Fail LED).

### 8.3 Configuring the Panel (from PC)

To allow configuration from a PC it is necessary to have the Loop Explorer 2 configuration programme installed on the computer and for the download lead (Part Number S187) to be plugged into the serial port of the computer or via a serial to USB converter.

The other end of the download lead should be connected to the "PC" connector which is exposed when the outer door is opened and is located to the left of the fuse fail LED indicator.

**NOTE:** The Loop Explorer 2 configuration software is only available as a download from the Virtual Resource web site ([virtualresource.global](http://virtualresource.global)).

In order to access this software, you will need a user login. This login will be provided by either your panel supplier or by your VR administrator. It is essential that you have this login before attempting to program this product.

Loop Explorer 2 also requires regular authentication. Failure to regularly authenticate this product will reduce the functionality and it will not be possible to connect and transfer configurations to the CIE

When configuring the panel from a PC, it is very important to ensure that the actual configuration of devices installed matches the PC configuration.

If this is not the case then there can be a bewildering array of missing and/or unexpected devices, which can be quite confusing and difficult to diagnose.

If the exact site configuration is not known in advance, it is possible to upload an Auto-Learned configuration to the PC, add text messages and any other changes required and then download this back to the control panel. This method ensures that the configurations match, is likely to proceed without errors and provides a quick and easy method of entering text and zone number information.

Panels that are configured from a PC can have default settings for devices changed (including call points) so the system should be thoroughly tested after a download to ensure that all devices respond as expected.

To retrieve a configuration from the panel and save it onto a PC, connect the S187 download lead to the PC port of the panel and to the serial port or serial to USB converter and then to the PC. Open the Loop explorer 2 configuration programme on the PC and select "Connect to panel" from the four options that are offered by the opening screen. Click OK and you will be given an option to save the file you are about to create.

Give the file a name that is easily identifiable with the site and the panel location/name. Panel location/name is particularly important on a networked system in order to distinguish networked panels from each other. Once the configuration file is created and the programme is open, there is an option in the panel settings to enable the panel name to be set and displayed on the panel. Always keep a backup of configuration files with a different name to the original such as filename 01, filename 02 etc.

To transfer the modified file back to the panel, first switch on the write enable switch at the panel by moving it to the left, click the Tools icon at the top of the screen, then click Transfer Configuration. Click the "Connect to Panel" button then "To Panel" then "Transfer to Panel". The file will now be sent back to the panel with any changes that were made on the PC. The panel will display RECEIVING NEW CONFIGURATION, PLEASE WAIT... during the file transfer process and will then display the start up screens as per the Auto learn sequence above.

When the file transfer has finished, switch off the write enable switch on the panel, enter access level 2 and press the front panel reset button and press Reset to clear the System Fault message.  
The panel will now contain the modified configuration from the PC.

## 9. Facilities Menus on CIE

A number of facilities are provided which can only be reached at access level 2 or 3.

Access level 2 can be reached by entering the correct password (a 4 digit number) and pressing the enter button (or by the optional Enable Controls key switch if fitted).

Access level 3 can only be reached from access level 2 and only by entering the correct, 4-digit password then pressing the enter button.

Panels that have not been configured, or have been configured using the Auto Learn option, have 2222 as the default password for Access level 2 and 3333 as the default password for Access level 3.

Passwords can only be changed using the Loop Explorer 2 PC configuration programme.

The Access level 2 password is required by the end user, to Silence/Acknowledge, Resound Alarms, Evacuate, operate the Function button and to Reset the system.

Any persons responsible for safety and who have been trained and authorised to use the fire alarm system should be made aware of the Access Level 2 password (or given the enable controls key where applicable).

**Without the Access Level 2 password or the enable controls key where applicable, it is not be possible to control the Syncro XT+ combined CIE/ECD control panel so it is most important that the responsible person knows the password or is in possession of the enable key.**

Main menu items available at access levels 2 and 3 are as follows:

<b>ACCESS LEVEL 2 (2222)</b>	<b>ACCESS LEVEL 3 (3333)</b>
Disablements	Edit configuration
View devices	Set times
Test Zones	View/print event log
Set system time	Print configuration
Contamination Status	Engineering Disablements and settings
Access level 3	Loop Data Test

Access level 3 enables a much higher level of control and must be restricted to persons trained and authorised to reconfigure the site-specific data and to maintain the panel. Typically, engineers of the fire systems company will be responsible for Access Level 3 functions.

**Before any changes are made to the configuration memory, using either the Edit Configuration or Set Times menu options, it will be necessary to CAREFULLY set the memory write enable switch to the left hand "Enabled" position, using a small screwdriver, or similar tool.**

## 10. Detection circuits

Syncro XT+ combined CIE/ECD control panels are configured to communicate using Hochiki or Apollo protocol.

Short circuit isolators must be fitted in the loop wiring such that a single short or interruption in the circuit will not prevent the indication of a fire alarm from more than 32 detectors and/or manual call points.

Power is driven from the "LOOP OUT terminals and is returned to the LOOP IN terminals, where it is monitored for detection loop continuity.

If the loop is open-circuit (a cable fault or short circuit isolator operated), the panel will drive power from both the LOOP OUT and LOOP IN terminals. This ensures that despite a single break or short circuit in the wiring, all of the devices will still remain connected to the control panel. In the case of more than one short circuit, the short circuit isolators either side of the short will isolate the faulty section of the wiring and the panel will report devices between the isolators as missing.

Both the LOOP OUT and LOOP IN connections of the panel are fitted with short circuit isolation so that a short on the cable between these terminals and the first isolator fitted to the detection circuit will be isolated, leaving the remainder of the circuit operational.

The detection circuits also supply power to operate loop-powered sounders and can provide up to 400mA in total on each circuit.

As the power required by detectors, call points and input/output units is relatively small, most of this power is available to drive sounders but the number of sounders which may be connected will depend on their volume setting and the number of other devices fitted.

Calculators are available for both Apollo and Hochiki detection circuit loading and these should be used if there is any doubt about the loading exceeding the maximum of 400mA.

Detection loops should be wired in a screened, fireproof cable (such as FP200) and terminated at the panel using brass cable glands. Detection loops should have the drain wire terminated at the cable gland.

## 10.1 Fitting additional detection circuit (loop card)

If an additional detection circuit (loop card) is to be fitted to a single loop Syncro AS, it must be of the same protocol (Hochiki ESP or Apollo) as the existing detection circuit.

To fit the loop card, the control panel must have mains and battery power removed.

The metal chassis should then be removed by removing the two fixing screws that hold it in place.

The loop card is supplied in a static dissipative bag and should remain in this bag until it is to be fitted.

As with all electronic components, this circuit board is very sensitive and can be easily damaged by electrostatic discharge.

Where possible, a static protective wrist strap should be worn when handling circuit boards. Where this is not available; it is advisable to touch a surface that is known to be connected to the earth of the fixed installation.

The additional loop card mounts on the left hand side of the main board and fits into two connectors labelled X7 and X8.

There are two mounting pillars on the main board to which the additional loop board should be fitted using the M3 screws and washers supplied.

If the panel is part of a network, there will be a network card fitted in the position where the additional loop card will fit. The network card must be removed by removing the two screws that hold it in position and easing it out of connectors X7 and X8 and the additional loop card fitted in its place and secured with the two screws that are supplied with it.

The network card should now be fitted onto the connectors on the loop card and secured into place on the two pillars with the original screws that held it in place.

After checking that the loop card is firmly located and making good contact with its connectors, the metal chassis can be screwed back into place in the enclosure.

Unused detection circuits must have the "LOOP + OUT" to "LOOP + IN" and "LOOP - OUT" to "LOOP - IN" terminals wired together to prevent open circuit faults from being reported. Links are supplied fitted to these terminals.

The devices on the new detection loop should be added to the original configuration file using the Loop Explorer 2 configuration programme and downloaded to the panel. If this is not done the panel will report unexpected devices on loop 2.

**CAUTION** – If an Autolearn is done to detect the devices on the additional loop, any previous configuration such as location text that had been allocated to the existing devices on the original loop will be erased. For this reason, it is preferable to update the control panel configuration via a PC using the Loop Explorer 2 configuration programme.

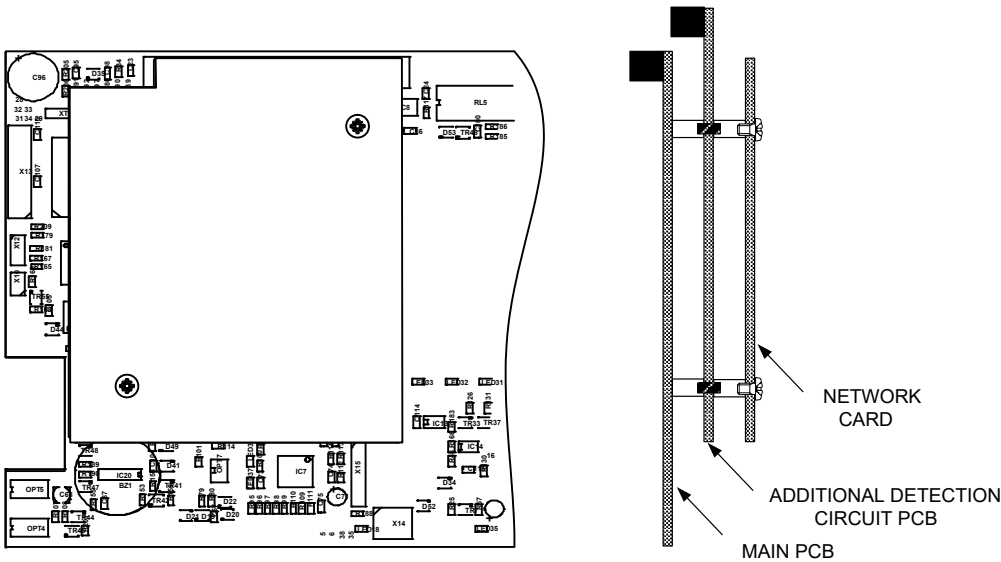

## 11. Loop sounders & Beacons

Loop powered sounders are available from Apollo and Hochiki. The quantity which may be connected to the loop depends on their volume and tone settings and the type and number of other devices connected to the same loop.

The permutations of devices are endless, so to assist with calculating the quantities of devices which may be connected, both Apollo and Hochiki has loop calculators available which will allow a simulation to be entered and warn of any permutations that are not allowable.

### 11.1 Apollo

Apollo Intelligent base sounders, Integrated base sounders and 100dB loop sounders may be set to two volume levels via segment eight of the eight bit DIL switch within the device itself. The Intelligent sounders have volume levels of 85dB or 92dB, the Integrated base sounders have volume levels of 75dB and 91 dB and the 100dB loop sounders have volume levels of 92dB or 100dB.

The current consumption of the Intelligent base sounder is 3mA at 85dB and 8mA at 92dB.

The Intelligent base sounder can be operated with only one tone, which is 500Hz/550Hz at 250mS intervals. This can be pulsed at 1-second intervals to give an alert warning if required. Apollo loop sounders can be used as a detector base or as a stand-alone device but either way; each sounder must be allocated a unique address in the range 1 to 126.

Apollo Ancillary base sounders are controlled by the remote indicator output of their host detector. As these sounders are not addressable devices, the Syncro AS panel will not be able to identify the device during the auto learn sequence. Therefore it is necessary to configure the Syncro AS panel to advise it that certain detectors have Ancillary Loop sounders installed. These devices are added to the system configuration file using the Loop Explorer configuration programme and are seen as address number (detector address +126). Once in the Loop Explorer configuration ancillary base sounders can be controlled by cause and effect programming.

The ancillary base sounders can be configured to respond to all output properties except for the Alert option, as the sounder cannot be pulsed.

### 11.2 Hochiki

Hochiki sounders can have 10 volume settings.

Each sounder can have its volume set independently or all sounders can have the same volume setting by changing the default volume on the panel settings page of the PC configuration programme.

Unless this default volume setting is changed, all sounders will have a volume setting of 85dB.

This table shows the volume levels available and the current consumption at each volume setting. Loop sounders that are used as a detector base do not need to be allocated an address in the range 1 – 127. The Syncro AS panel will automatically address base sounders by adding 127 to the address of the detector to which they are connected during the panel autolearn process. This means that it is possible to fit 127 detectors and 127 base sounders to a loop (dependent on sounder volume).

It is possible to alter the address of base sounders but the address will revert to 127 above the host sensor address if the panel is autolearned.

Wall sounders however must be addressed in the address range 1 to 127, using a hand held programmer, and will retain their address setting at all times.

Because each loop sounder has its own address, it is possible using the PC configuration programme (Loop Explorer) to perform cause and effects on each sounder or groups of sounders as required. This gives great scope for controlling the annunciation of the fire alarm for all types of building.

VOLUME	CURRENT
70dB	0.8mA
78dB	1.5mA
80dB	2.0mA
85dB	3.0mA
88dB	4.5mA
90dB	6.5mA
93dB	8.0mA
94dB	10mA
95dB	11mA
98dB	16mA

#### 11.2.1 Hochiki sounder Tone Settings

It is possible to change the tone of all Hochiki loop sounders, to one of 51 different tones unless older CHQ-BS devices are fitted in which case the number of tones is restricted to 7.

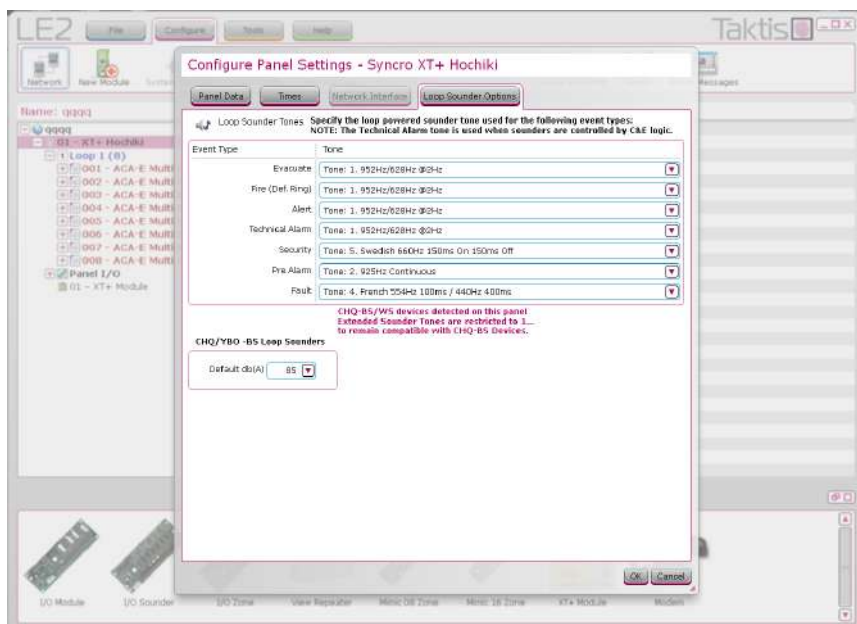

Each event type has been allocated a separate default tone and these may be changed from the default by selecting the "Loop Sounder Options" tab from the panel settings window.

This window shows all of the event types and their default tones. All or any of these may be changed to another tone and it is possible for more than one event type to use the same tone.

Loop sounders will default to operate upon a fire condition. It is possible however, to operate loop sounders upon any of the seven event types. It is also possible to operate loop sounders upon more than one event although under these circumstances a hierarchy exists as follows:

- EVACUATE
- FIRE
- ALERT
- TECH ALARM
- SECURITY
- PRE-ALARM
- FAULT

As can be seen from the above, a loop sounder which is sounding a TECH ALARM will change its tone in the event of EVACUATE, FIRE or ALERT events if it is programmed to respond to all of these.

Loop sounders can be programmed to operate upon any of the event types using the configure settings window as shown below. This window also allows the volume of the sounder to be changed from the default value, stage 1 and stage 2 delays to be set and the sounder to be selected Silenceable or not as required.



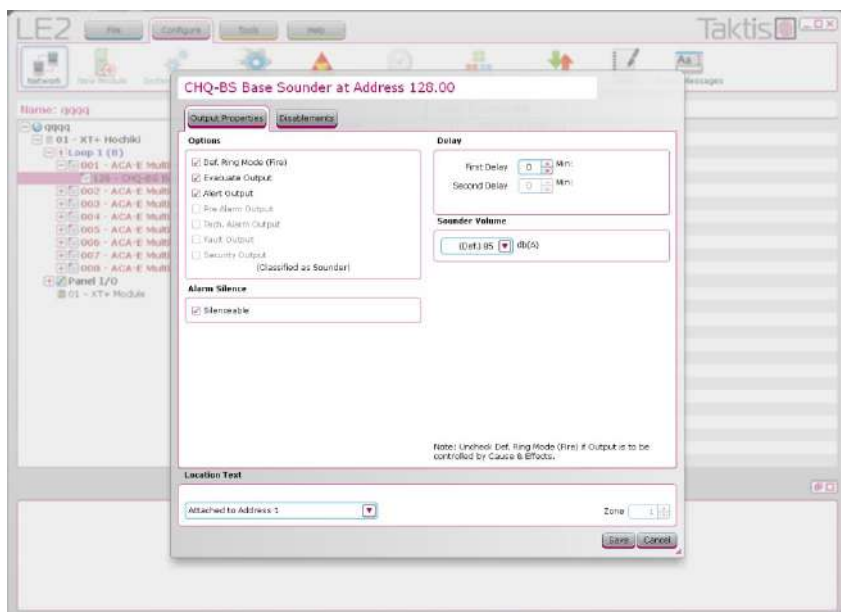

**NOTE:** If a loop sounder is controlled by a cause and effect operation, then the Tech Alarm tone will be used when the sounder is energised.

The possibility to change tones allows the fire alarm infrastructure to be utilised to a much greater extent for other types of audible signalling than simple pulsing or steady sounder systems.

For class change applications as an example, different tones could be used to signal class change and break times. This could also apply to the factory environment to signal break and shift changes.

The ability to operate individual sounders from dedicated inputs also allows the system to be used for fire door monitoring such that the sounder nearest the door can emit an alternative tone if the door is opened in a non-emergency situation.

## 12. Panel Sounder circuits

Two conventional sounder circuits are provided on the CIE in the panel each capable of supplying up to 500 milliamps, each fused at 1.0A. A 10K end of line resistor monitors the circuits for open and short circuit faults.

Both circuits are configured to activate upon any fire condition and to de-activate when the Silence Alarm/ Acknowledge button is pressed on the front panel or a silence input is operated. Each sounder circuit can be configured independently via the PC configuration programme or the front panel pushbuttons (at Access level 3).

This allows sounder circuits to be operated by different methods such as zonal alarm or via cause and effects.

### 12.1 Stage one and stage two delays

The sounder circuits can have a single or two-stage delay if required. The first stage of delay allows up to 10 minutes for the alarm to be acknowledged in 0.5 minute steps.

If the alarm is not acknowledged before the first stage delay expires, then the sounders will operate.

If the alarm is acknowledged during the first stage delay, the second stage delay (again up to 10 minutes in 0.5 minute steps) will start.

If the alarm is acknowledged during the first stage delay and the second stage delay is zero then the sounders will not operate.

If the Alarm is acknowledged during a second stage delay, the second stage delay (up to 10 minutes) will start and the sounders will operate at the end of the delay unless the panel is reset.

Activation of two or more devices producing a fire action, a call point or an input configured to override output delays, will override the delays and operate the sounders immediately.

Note: Setting the total combined first stage and second stage delays to greater than 10 minutes is not compliant with the requirements of EN54-2.

## 13. Sounder controllers

Sounder controllers are available in the Hochiki and Apollo ranges of devices and can be used for controlling conventional sounders from the detection loop.

The wiring to the sounder circuits is monitored for open or short circuit faults by fitting an end of line monitoring device.

The sounder controller outputs are fully programmable as described in [section 11](#) and [section 19](#).

Sounder controllers require an additional 24V DC supply to power the conventional sounder circuits (or other equipment) connected to them. This power supply is also monitored for failure by the control panel.

## 14. Relays

Relay contacts rated at 30 Volts DC at 1 Amp are provided for ancillary switching functions in all panels.

Under no circumstances should voltage or current outside of this limit be used with these contacts.

The default actions of these contacts as supplied from the factory are as described below: -

### 14.1 CIE relays

NAME	ACTION
------	--------

FIRE	Activates on any fire condition and remains active until panel is reset (changeover)
FAULT	Activates on any fault or on total loss of power and clears when faults are cleared (changeover)
ALARM	Activates on any alarm, de-activates when alarm silenced / acknowledged (changeover)

Each volt free changeover contact can be reconfigured independently for other actions via the PC configuration programme or the front panel pushbuttons (at access level 3).

This includes delays as described for the sounder circuits above.

### 14.2 ECD module relays

NAME	ACTION
------	--------

FAULT	Activates on any fault on the module or on total loss of power and clears when faults are cleared (changeover)
1 <sup>st</sup> Stage	Activates when the first zone configured to contribute to extinguishing release operates (Normally open)
2 <sup>nd</sup> Stage	Activates when the second zone configured to contribute to extinguishing release operates (Normally open)
Released	Activates when the Released condition is established (Normally open)
Aborted	Activated when the Aborted condition is established (Normally open)
Extract	Activates when the Extract condition is selected at access level 2 (Normally open)

## 15. Inputs

### 15.1 CIE inputs

Five inputs are provided in the panel, which have default actions as described in the table below:

INPUT	DEFAULT ACTION
-------	----------------

FLT	Operates outputs configured to operate on fault condition.
RES	Resets the control panel
INT	Operates all sounder outputs intermittently
CNT	Operates all sounder outputs continuously
SIL	Acknowledges the alarm (silences all sounders)

Note: The RES / INT / CNT / SIL inputs should only be available at Access Level 2. Care must be taken to ensure these inputs cannot be operated without some form of access control in order to maintain conformity to EN54-2.

All inputs can be re-programmed to have a different action, delay, zone and location message using the PC configuration programme or front panel controls (at Access level 3). To activate the inputs, the 0V connection is connected to the input(s).

All inputs are non-latching as default.

The line impedance should be less than 50 ohms for reliable operation

### 15.2 ECD inputs

Inputs to the ECD module are monitored for open and short circuit fault and require a 6K8 end of line resistor for line monitoring and a 470R resistor applied across the input for activation.

INPUT	ACTION
Manual Release	Puts the module into the activated condition.
Hold	Puts the module into the Hold condition
Abort	Puts the module into the Abort condition
Mode	Changes from Automatic and Manual mode to Manual only mode
Rel.P.Sw	Establishes the released condition (does not operate the extinguishing outputs)
Low Press	Causes a fault condition on CIE and ECD (Exting. Pressure)

On remote modules, 2 additional inputs monitored and activated as above are provided for Activation inputs. These may be activated by volt free contacts form other CIE panels of addressable modules.

Act I/P1	Module activation input
Act I/P12	Module activation input

## 16. I/O serial busses

### 16.1 CIE remote serial bus

The Syncro XT+ control panel CIE part has a serial communications bus to which the ECD modules are connected. Additional remote extinguishing modules, 16 channel I/O boards, relay boards, sounder boards and conventional detection zone boards may also be connected to this bus. This serial bus also supports up to 15 of the full function Syncro View repeater panels.

Up to 32 I/O units in total can be connected to the serial bus and these can be a mixture of any type.

ECD modules are consecutively pre- addressed at the factory starting at address 1 and up to the number of modules fitted. Any additional remote ECD modules, I/O boards or View repeater panels should have their own bus address different from all other devices connected to the bus.

Limited numbers of these units may be connected to the panel's Auxiliary 24V supply however the fuse rating of the Auxiliary supply and the effect of the extra power required on battery standby must be taken into consideration. Full details of power consumption for devices that connect to the serial I/O bus can be found in the O&M manuals of the individual devices.

Because the primary connection at the CIE part is already used for connection to extinguishing modules, further connections to this bus must be made at the last of the extinguishing modules as shown below.

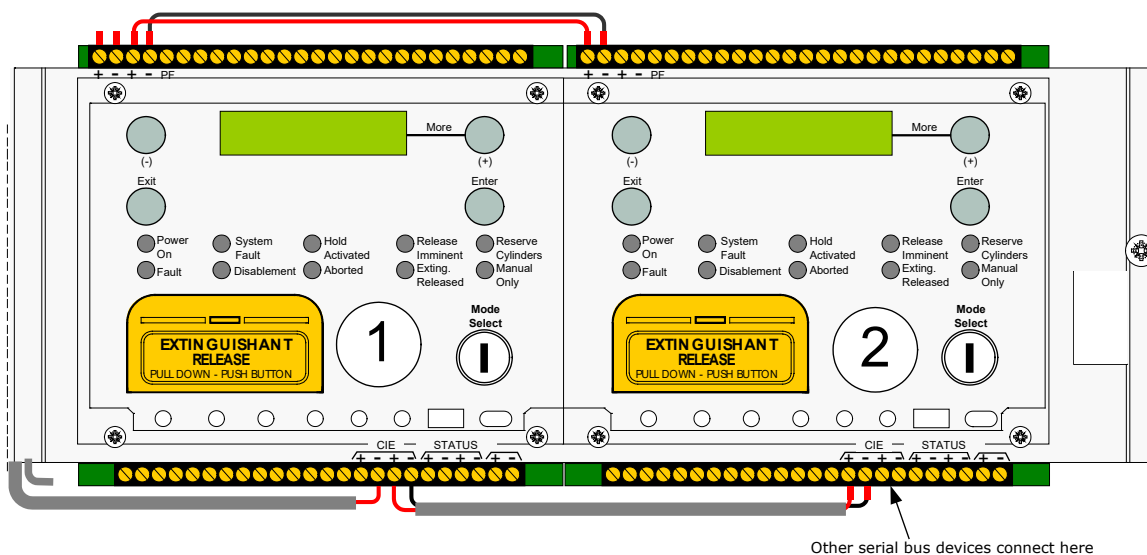

#### 16.1.1 - 16 channel I/O board

The 16 channel I/O boards can be individually configured using the Loop Explorer configuration programme and each channel can be an input or an output.

When added to a control panel, all channels default to inputs with and their action when activated will be FAULT. Any or all channels may be changed to outputs via the Loop Explorer configuration programme. When channels are changed to outputs they will default

to DEFAULT RING MODE. This means that they will switch on when a fire condition is present on the control panel as COMMON ALARM, ZONED ALARM or 2-STAGE ALARM (see section 19.3.2).

Inputs to these boards are via opto-isolators, which offer good protection against noise and transient voltages. Channels configured as outputs have an open collector transistor, so must be used with care to avoid damage by shorting or sourcing too much current. For full details of 16 channel I/O boards refer to manual MAN-1056.

**16.1.2 - 8 way relay board**

The 8 way relay boards have individual, volt free changeover relay contacts which can be configured using the Loop Explorer configuration programme to operate in response to alarms or cause and effects as required.

Relay contacts are rated at 30V DC 1 Amp. For full details of 8 way relay boards refer to manual MAN-1074.

**16.1.3 - 6 way sounder board**

The 6 way sounder boards has 6 voltage reversing, monitored sounder outputs which can be programmed to operate as required on response to alarms or cause and effects.

The sounder boards also have 2 programmable, volt free changeover relay contacts and 2 opto isolated inputs all of which are also fully programmable via the Loop Explorer configuration programme. For full details of 6 way sounder boards refer to manual MAN-1075.

**16.1.4 - 4 way zone board**

The 4 way zone board has 4 conventional detection zones, 2 monitored sounder outputs and two programmable volt free, relay contacts which default to fire and fault actions.

The 4 way zone board is in effect a self contained 4 zone conventional control unit. For full details of 4 way zone boards refer to manual MAN-1077.

**16.1.5 - Syncro View repeater unit**

The Syncro View repeater is a very cost effective, full function repeater panel that connects to the remote serial I/O bus and provides full indication and control of all panels' status and functions in a compact, slimline enclosure.

Up to 15 View repeaters may be connected to the serial bus as well as any combination of the other types of I/O boards up to a maximum of 32.

View repeaters have a low standby current consumption and can be powered by the Aux 24V output of the Syncro AS control panel. For full details of Syncro View repeater units refer to manual MAN-1092.

**16.2 ECD remote serial bus**

The Syncro XT+ panel extinguishing modules each have a remote serial bus for connection to status indicator and control units and/or ancillary boards.

Up to 7 status units and ancillary boards can be connected and these can be a mixture of any type.

Status units and ancillary boards require a four-wire connection from the associated extinguishing module, which drops into each unit and connects to the corresponding data and power, in and out terminals. Two of the cables carry power to the units (24V) and the other two carry data. A four core cable suitable for carrying RS485 data should be used. If this is a twisted pair cable then one twisted pair should be used for the data connections and the second pair used for the power connections.

When fitting status or ancillary boards, link LK2 must be removed from the rear of the extinguishing module. The last status unit connected to the serial bus will have a terminating link fitted as described in manuals MAN-1089 and MAN-1095.

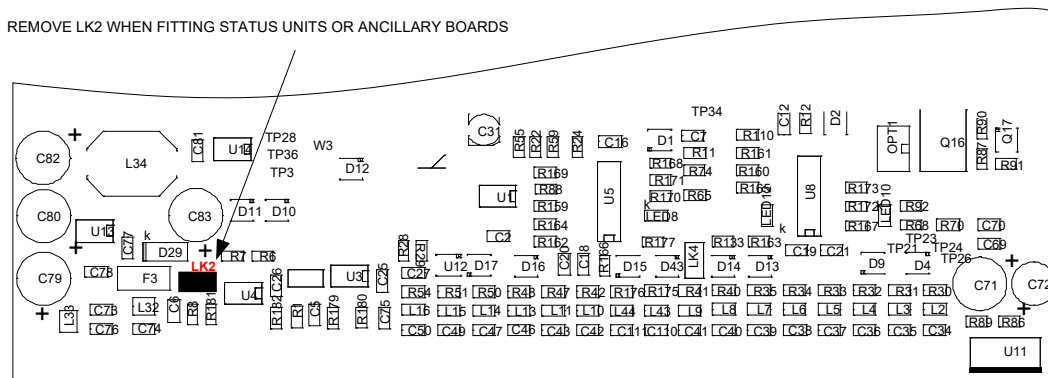

**REAR VIEW OF EXTINGUISHING MODULE**

Each status unit and ancillary board has a 3-bit DIL switch and must be allocated a unique address between 1 and 7. A maximum of 3 status units or Ancillary boards can be powered from the extinguishing module 24V output. More units should use an external 24V power supply.

The system is able to distinguish between status units and ancillary boards so it is possible to have a status unit set to address 1 and an ancillary board set to address 1 if desired.

The address switch is located on the bottom left hand corner of the status unit or ancillary board PCB.

Note: The address is only read when the boards are first powered or if the processor reset switch on the ancillary board or status unit is pressed, so address switches should not be altered on a system that has power applied.

It is important that each individual status unit and ancillary board is allocated a unique address in the range 1 to 7. Units of the same type with the same address will cause intermittent faults to be displayed.

**NOTE:** 10 lamp status units (models K911113M8, K911113F8 and W911113W8) are not compatible with Syncro XT+ panels.

### 16.2.1 Adding new status units/ancillary boards

When the system is powered up, it will search for connected status units and/or ancillary boards connected to extinguishant modules.

If status units or ancillary boards are fitted and detected by the control panel, the LCD will display:

```
X FAULTS      ► X = the number of faults
ENTER TO VIEW
```

Press ENTER on the module to which the status units or ancillary boards are connected with the ENABLE control switch keyswitch off and use the UP button on the module to view the faults. If status units and/or ancillary boards are detected the LCD will display:

```
STATUS UNIT X   X = the address of the status unit found
  FAULT
```

Or

```
OUTPUT UNIT X   X = the address of the ancillary board found
  FAULT
```

To accept the status units and/or ancillary boards found, turn the ENABLE controls keyswitch on and slide the WRITE ENABLE switch on the module to which the status units or ancillary boards are connected gently to the left.

The LCD will then display:

```
STATUS UNIT X   X = the address of the status unit found
ENTER TO ACCEPT
```

Or

```
OUTPUT UNIT X   X = the address of the ancillary board unit found
ENTER TO ACCEPT
```

When the ENTER button is pressed on the module to which the status units or ancillary boards are connected, the selected status unit or ancillary board will be added to the system and the next unit to be added will be displayed. Press the ENTER button on the extinguishing module until all of the units have been accepted then gently slide the WRITE ENABLE switch on the module to the right.

All of the status units and ancillary boards found by the extinguishant module have now been added and disconnection of any of them will be displayed as a fault on the module and on the detection part of the system. If any status units are disconnected, a HOLD activated indication will also be displayed at the extinguishing module and all ancillary boards or status units that remain connected. With the ENABLE controls keyswitch off, the LCD will display:

```
REMOTE BUS
  FAULT
```

When additional status units or ancillary boards are added to the system, these will be shown on the LCD of the extinguishing module when the system is powered up or the processor reset switch is pressed on the module to which the status unit or ancillary board is connected and can be added to the system by following the procedure above.

### 16.2.2 Removing status units or ancillary boards

If a status units or ancillary board needs to be removed from the system, disconnect the status unit or ancillary board taking care not to short power supply or data cables. The extinguishing module will display:

```
REMOTE BUS
```

## FAULT

Press the processor reset button on the extinguishant module to which the status unit or ancillary board is connected. When the extinguishant module has re-started, it will display:

STATUS UNIT X  
FAULT X = the address of the disconnected status unit

Or

OUTPUT UNIT X  
FAULT X = the address of the disconnected ancillary board

Turn the ENABLE controls keyswitch on and gently slide the write enable switch on the extinguishant module to which the status units or ancillary boards are connected, to the left. The LCD will then display:

STATUS UNIT X  
ENTER TO ACCEPT X = the address of the remaining status units found

Or

OUTPUT UNIT X  
ENTER TO ACCEPT X = the address of the remaining ancillary boards unit found

When the ENTER button is pressed on the module to which the status units or ancillary boards are connected, the selected status unit or ancillary board will be added to the system and the next unit to be added will be displayed. Press the ENTER button on the extinguishing module until all of the units have been accepted then gently slide the WRITE ENABLE on the extinguishing module switch to the right.

Full details of status units and ancillary boards can be found in documents MAN-1089 (Sigma XT Status unit operation and maintenance manual) and MAN-1095 (Ancillary board operation and maintenance manual).

### 17. Power supply

The control panel is fitted with an EN54-4 approved 5.25A Amp power supply and battery charger capable of charging up to 26Ah batteries. A separate power supply should be used if larger batteries are required. The panel can house batteries of up to 15Ah (12Ah format type)

The power supply requires a 230V AC mains connection.

The power is split between the charging circuit and power supply such that a maximum of 1.25A Amp is available to charge the batteries if required, which leaves 4 Amps to run the control panel and peripherals. If the batteries are fully charged and do not require any power, the full 5.25 Amps is available to run the control panel and sounder load.

The power supply incorporates sophisticated monitoring of the condition of the power system. The battery charging output is temperature compensated to maximise the service life of the batteries and a high impedance in the battery supply circuit will be indicated as a fault condition.

The following fault conditions are signalled at the control panel: -

MAINS FAILED  
BATTERY DISCONNECTED  
BATTERY LOW VOLTAGE  
EARTH FAULT

The mains fuse fitted is a T3A 250V HRC 20mm type and must be replaced upon failure with a fuse of the same type to maintain the safety rating of the power supply.

#### 17.1 CIE Aux. 24V supply

A separately fused auxiliary 24 Volt output is provided for powering additional I/O boards or other equipment connected to the system. When switching inductive loads such as relays, these MUST be adequately suppressed using a reverse connected diode.

The Aux 24V supply fuse is of the self-resetting type and is rated at 500mA. Failure of the fuse is monitored by the system and announced as "Aux. 24V fuse failed". The fuse will reset once the overload is removed and the system is power cycled.

The impact on battery standby duration must be carefully considered when using the Aux 24 volt output. Constant use of the full 500mA capability of this output for instance would require an additional 15Ah of battery capacity for 24 hours standby so any equipment requiring permanent power should be powered from a separate source . Ideally, use of the Aux. 24V output should be restricted to powering a limited number of additional I/O boards or switching equipment when an alarm condition occurs.

### **17.2 CIE 24V OUT terminals**

The terminals on the circuit board marked 24V OUT should not be used for any part of the installation. These terminals are reserved for powering additional equipment that is factory fitted only. Using these outputs to power equipment outside of the panel enclosure will compromise the integrity of the system.

### **17.3 CIE Remote PSU**

The terminals are reserved on the Syncro XT+ panel and should not be used.

### **17.4 Battery capacity**

To enable the system to continue to function in the event of a failure of the mains supply, suitable batteries must be fitted. These are not supplied with the control panel.

Batteries should be of the re-chargeable, sealed lead acid type. They should be new (less than six months old) and sized according to the local codes of practice for the standby period required, preferably by measuring quiescent and alarm loads for the particular hardware configuration installed or using the formula listed below to calculate the required capacity.

The battery capacity required can be calculated using the following information.

$$(Quiescent\ load\ (A)) \times Standby\ period\ (hours) + ((Alarm\ load \times 1.75)/2) \times 1.25 = Ah$$

The maximum size of battery, which can be fitted inside standard control panels, is 15 Ah.

Batteries above this size will need to be fitted in a separate enclosure and charged by a suitably rated battery charger.

Any additional load connected to the system from the Aux. 24V output or Status power outputs such as additional I/O boards and status units should be catered for by additional capacity using the same formula as above and adding the result to the calculated capacity required to maintain the control panel.

The current consumption of additional I/O boards is as follows:

- 16 channel I/O board - 20 milliamps quiescent, up to 1A full alarm
- 8 way relay board - 10 milliamps quiescent, 250 milliamps alarm
- 6 way sounder board - 30 milliamps quiescent, 260 milliamps alarm (plus sounder load)
- 4 way conventional zone monitor board - 70 milliamps quiescent, 200 milliamps alarm (plus sounder load)
- Sigma Si Status unit - 70 milliamps
- Sigma XT ancillary board - 25 milliamps quiescent, 175 milliamps alarm

If several I/O boards, status units or Sigma XT ancillary boards need to be powered then it is likely that the maximum available standby battery capacity will be exceeded and a separate, EN54-4 compliant power supply and battery set should be installed to power these.

The standby power requirements for the detection devices, call points, modules and loop powered sounders should be calculated using the device manufacturers technical data. Some device manufacturers have calculators available to assist with this.

## **18. Programming via a PC**

The Syncro XT+ combined CIE/ECD is highly configurable and can be programmed in an almost infinite number of ways, some of which will not give the visual and audible indications expected from a fire and extinguishing system.

Any re-programming from the factory default settings must therefore be carried out by competent fire systems engineers and thoroughly tested against the system plans before final commissioning.

Although the Syncro XT+ is very powerful and can be programmed to perform some complex tasks, the principals adopted in the way that inputs and outputs are handled make it conceptually very simple.

### **18.1 Panel settings**

There are a number of attributes for the panel which can be changed using the configuration programme as shown below.

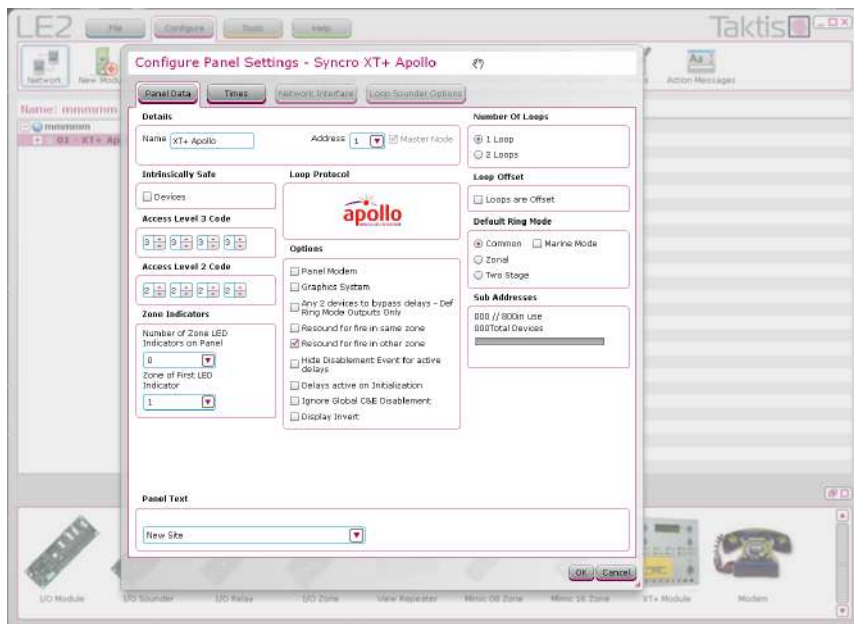

### 18.1.1. Panel name

By default the panel name will be set to the panel type.

If the panel is part of a network of panels, it can be useful to have a panel name, which would normally describe its location such as the name of the building or facility where the panel is mounted.

The panel name can be up to 15 characters long.

### 18.1.2. Panel address

To enable control panels to know about each other when connected to a network, each panel must have a unique address. This is the node address and should be a number between 1 and 64. Syncro XT+ panels that do not have a network card installed will always default to address 1.

### 18.1.3. Protocol

Control panels are supplied as Apollo or Hochiki compatible.

The label inside the control panel showing the part number identifies which protocol is being used by starting with either an H (Hochiki) or an A (Apollo).

When making a configuration file, the correct protocol panel must be selected.

Repeater panels are protocol independent.

### 18.1.4. Number of loops

Control panels are supplied with 1 or 2 detection loops fitted. The configuration file should be created with the same number of loops as the control panel for which it is destined.

### 18.1.5. Default ringing mode

When control panels are supplied, the default-ringing mode is set to common alarm. In this mode, any fire condition will operate all sounders continuously.

The mode can be changed to zonal alarm, which means that only sounders in the same zone as the signal that originated the alarm will operate.

A third option of 2-stage alarm is also available which causes the sounders in the same zone as the signal that originated the alarm to operate continuously and sounders in all other zones to operate intermittently.

### 18.1.6 – Marine Mode

This option applies to the Syncro ASM panel only and should be left de-selected.

### 18.1.7. Access level code changes

The default codes to enter access level 2 and access level 3 can be changed via the configuration programme only.

### 18.1.8. Panel text

A forty-character message can be entered which is displayed when the control panel is in a quiescent condition. This may be the company name and service contact telephone number or any other message agreed with the end user.

### 18.1.9. Panel Modem Fitted

When selected, the panel expects a modem to be fitted to the PC port. The panel will poll the modem at 90-second intervals and expect a response from the modem. If the modem does not respond, then a disconnected modem message will be shown on the panel display.



### **18.1.10. Graphics System**

When this is selected, event cleared messages will be sent to the PC port and printer port. This allows a graphics system to track and automatically clear events, provided this facility is supported by the graphics system. This is deselected by default, to reduce printer paper consumption. When selected, event cleared messages will be printed after each event or activation has been reset.

### **18.1.11 – Loop Offset**

This option applies only to networked systems. By default the device address will comprise the panel number, loop number and device address number. The loop number will be either 1 or 2 for a Syncro AS panel.

If the loop offset option is selected, the loop numbers are shown as the next incremented loop number from the previous network panel. Therefore for a network of four AS panels, some with offset selected, the loop numbers will be as shown in the example below

Panel 1 (Syncro XT+ 2 loops) – Panel 1 Loop 1, Panel 1 Loop 2

Panel 2 (Syncro XT+ 2 loops and loop offset selected) – Panel 2 Loop 3, Panel 2 Loop 4

Panel 3 (Syncro XT+ 1 loop, NO loop offset selected) – Panel 3 Loop 1

Panel 3 (Syncro XT+ 2 loops with loop offset selected ) – Panel 4 Loop 2, Panel 4 Loop 3

### **18.1.12 – Apollo Intrinsically Safe Devices**

This option is only shown for the Apollo protocol panel and should be selected when using Apollo XP95 Intrinsically Safe (IS) devices connected to the detection loop via an XP95 protocol translator and barrier arrangement.

When selected, the maximum number of detection device LED indicators that can be consecutively illuminated is reduced from the default of 5 to 2 indicators, to reduce current through the translator / barrier hardware.

### **18.1.13 – Zone Indicators**

This option typically applies to networked systems and allows the 16 "Fire in Zone" indicators to be re-mapped to alternative zones in steps of 16 zones.

Therefore on a networked system with panels in different buildings, panel 1 could display zones 1-16, panel 2 displays 17-32 etc.

**Note:** Special panel screening is required to ensure that the correct indicators are mapped to the appropriate zone label.

### **18.1.14 – Display Invert**

This option is used to change the LCD status display format. By default, black lettering is shown on a green background.

Selecting this option will change the display to green lettering on a black background. This is useful in reducing the brightness of the display when the panel is installed in darkened locations, such as control rooms and ships bridges.

### **18.1.15 – Any 2 devices to bypass delays – Def Ring Mode outputs only**

When this option is set, any delayed outputs configured to respond to the Default Ring Mode pattern will operate immediately upon the activation of any second fire signal.

This applies to any combination of two detection device types anywhere on the Syncro network.

### **18.1.16 – Resound for fire in same zone**

When a fire occurs in a zone and the sounders have been silenced, by default the sounders will not activate when a second detector in the same zone goes to fire.

Selecting this option will cause the silenced sounders to activate from a second detection device fire in the same zone.

### **18.1.17 – Resound for fire in other zone**

When a fire occurs in a zone and the sounders have been silenced, by default the sounders re-sound when new fire event is reported from a different zone.

Deselecting this configuration option will stop the silenced sounders from activating on the new zone fire event.

### **18.1.18 – Hide Disablement Event for active delays**

This option applies to V5.xx firmware control panels only. EN54-2 required that systems configured with delayed outputs there should be the facility to "disable" the immediate operation of the outputs, to turn the delay function on. The standard specified that this facility was a disablement event and therefore the general disablement indicator had to be illuminated whilst the delay facility is active, which was unpopular in some markets. Selecting this option suppressed the General Disablement indication and the "Immediate operation disabled" event.

Amendment A1 of EN54-2 revised the requirements for the switching on/off delays so that the disablement event was no longer necessary. V6.xx firmware panels are designed to the revised EN54-2 standard and therefore this option is obsolete.

### **18.1.19 – Delays active on initialisation**

This option will switch delays on by default when the panel is restarted or powered on. It is recommended that this option is selected on any system where delayed outputs are configured.

### **18.1.20 – Ignore Global C&E Disablement**

When disablement cause and effects are configured and activated, they are shown in the status windows of all networked panels regardless of the network interface settings or whether any items are disabled on the panels by the cause and effect. Selecting this option will only show the disablement cause and effect active event on networked panels that have inputs or outputs disabled as result of the disablement cause and effect.

### **18.1.21. Day/Night times**

Day night change times can be set for each day of the week by selecting the Times tab on the panel settings screen.

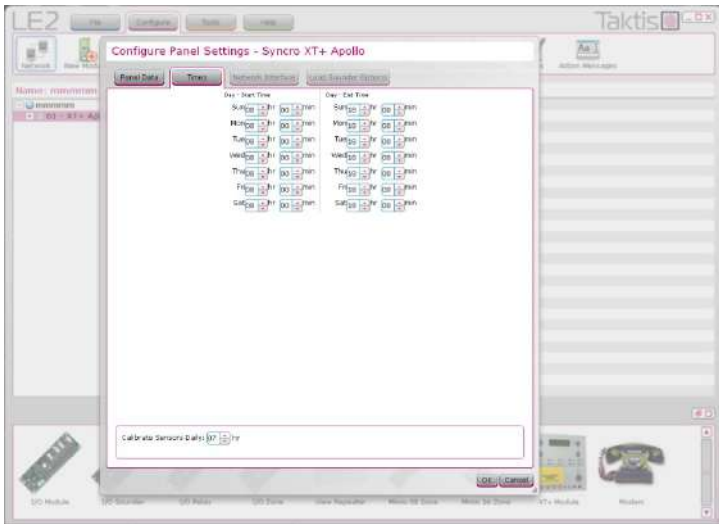

The sensitivity of detectors can be varied during a 24-hour period. This is commonly known, as Day/Night mode but can be either or both as any period in any 24 hours can be selected as day or night.

It is only necessary to set the day start and end times for each day of the week.

**18.1.22. Calibration time**

All sensors are re-calibrated every 24 hours. This time is selectable, so that sensors are not calibrated at a time when there is a high background pollution level. The calibration time should be set to a time when the building is quiet, with little air movement.

**18.1.23 Network Interface**

In a networked system, each panel can be configured to respond to individual event types from any or all other panels on the system. The default setting is for all panels to respond to and display all events.

By selecting the appropriate tick boxes, each panel can be configured to respond in a unique way.

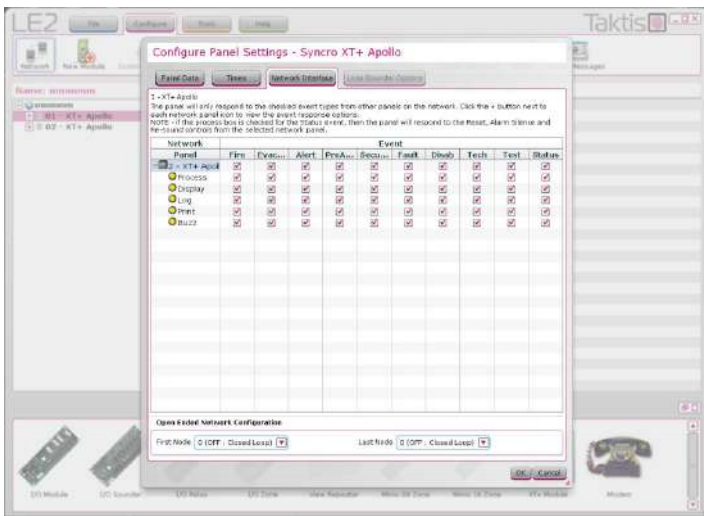

**18.1.24 Loop Sounder Options**

For Hochiki systems, it is possible to select the default volume of all CHQ-BS loop powered sounders. Each sounder may be configured independently to either the default setting or one of 10 volume settings.

NOTE: Volume settings of CHQ-WS 100dB wall sounders may not be configured from the control panel, even though this device has the same type code as the CHQ-BS loop sounder.

For Apollo systems, it is possible to select the default volume of all Discovery Sounder / Sounder Beacon devices. Each sounder may also be configured independently to either the default setting or one of 7 settings

## 18.2. Inputs

To simplify programming and promote an easy understanding of the system, the operation of the Syncro AS panel has been designed around a very simple principle.

This principle is that all inputs are handled in exactly the same way, whether they are from a loop device, a programmable input on the panel, an I/O board or the programmable pushbutton on the front panel.

This means that any input (apart from a smoke or heat sensor which must always report fire) can be allotted a set of attributes, which define how the control panel will respond when the input is activated.

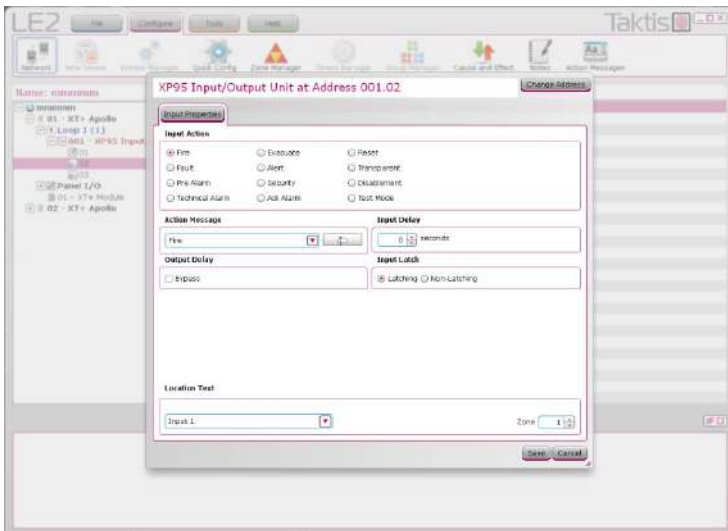

As can be seen from the screen capture of the PC configuration programme below, there are many attributes to choose from for each input.

The key to the flexibility of the Syncro AS system is the ability to vary these attributes for each input.

Inputs (other than sensors) need not simply report a fire or fault but can be used to signal all manner of other conditions and to control the system in many different ways.

Probably the most useful of these attributes is the INPUT ACTION and the following describes how the control panel will respond to each of these.

As mentioned previously, because this is fundamentally a fire system, automatic sensors cannot have their action attributes changed. For sensors the attributes, which may be altered, are as follows:

ADDRESS (1-240)

ZONE (0-500)

LOCATION TEXT (Up to 40 characters)

DAY SENSITIVITY

NIGHT SENSITIVITY

INDICATE PRE-ALARM

LOOP SOUNDER FITTED AS DETECTOR BASE

INPUT DELAY

OUTPUT DELAY BYPASS

For all other types of input however, there is an input action attribute, which empowers the system with control possibilities way beyond that of a normal fire alarm. Care must be taken to ensure that the system complies to the requirements of EN54-2 and local fire regulation requirements when these inputs are configured with delays or different input actions.

The following describes how the control panel will respond to each of these input actions.

### 18.2.1. Fire action

Being a fire control panel, the fire action will probably be the most widely used and a fire input will be announced by the following:

COMMON FIRE LEDS

ZONAL FIRE LEDs (If fitted)

PULSING BUZZER

PANEL SOUNDER OUTPUTS

ALARM CONTACT

FIRE CONTACT  
LCD FIRE MESSAGE, ADDRESS AND LOCATION TEXT OF INPUT

#### **18.2.2. Fault action**

Inputs attributed the fault action will be announced by the control panel as follows:

GENERAL FAULT LED  
CONTINUOUS BUZZER  
FAULT CONTACT  
LCD FAULT MESSAGE, ADDRESS AND LOCATION TEXT OF INPUT

#### **18.2.3. Pre-alarm action**

Sensors or inputs can generate a pre-alarm. The control panel will respond as follows to a pre-alarm:

PRE-ALARM LED  
CONTINUOUS BUZZER  
LCD PRE-ALARM MESSAGE, ADDRESS AND LOCATION TEXT OF INPUT

#### **18.2.4. Tech. alarm action (Technical alarm)**

To allow a message to appear at the panel without necessarily performing any actions, technical alarm input is available which produces the following response by the panel:

CONTINUOUS BUZZER  
LCD TECHNICAL ALARM MESSAGE, ADDRESS AND LOCATION TEXT OF INPUT

#### **18.2.5. Evacuate action**

The evacuate action allows all sounder outputs and sounders to be operated continuously from an input anywhere on the system with the following response at the panel:

COMMON FIRE LED's  
CONTINUOUS BUZZER  
ALARM CONTACT  
PANEL SOUNDER OUTPUTS CONTINUOUS  
LCD EVACUATE MESSAGE, ADDRESS AND LOCATION TEXT OF INPUT

#### **18.2.6. Alert action**

The alert action allows all sounder outputs and sounders to be operated in a pulsing mode from an input anywhere on the system with the following response at the panel:

CONTINUOUS BUZZER  
PANEL SOUNDER OUTPUTS PULSING  
LCD FIRE ALERT MESSAGE, ADDRESS AND LOCATION TEXT OF INPUT

#### **18.2.7. Security action**

The security action allows appropriately configured Hochiki CHQ-BS sounders to sound the selected Security tone from an input anywhere on the system with the following response at the panel:

LCD SECURITY ALERT MESSAGE, ADDRESS AND LOCATION TEXT OF INPUT  
CONTINUOUS BUZZER

#### **18.2.8. Silence alarm action**

An input programmed as Silence will silence any sounders that are operating and display an event message on the panel for the duration of the input being activated. The event is also stored in the event log.

#### **18.2.9. Reset action**

An input designated as reset will not produce any visible effect at the control panel but will reproduce the action of the reset button on the panel i.e. reset the alarms.

LCD RESET MESSAGE

#### **18.2.10. Transparent action**

A transparent input will have no effect at all on the panel. The only result of a transparent input is to control outputs via cause and effects configuration

#### **18.2.11. Disablement action**

Disablement inputs are used to disable a part or parts of the system via cause and effects configuration (normally for testing purposes).

When an input designated as a disablement is operated, the panel will display the following:

GENERAL DISABLEMENT INDICATOR  
CONTINUOUS BUZZER  
ADDRESS (1-240)  
ZONE (0-500)  
LCD DISABLEMENT MESSAGE, ADDRESS AND LOCATION TEXT OF INPUT

Note: If sounders are disabled by the action of a cause and effect then the Sounders Disabled LED indicator will also be lit.

### 18.2.12. Test mode action

Inputs given the test mode attribute activate a special type of cause and effect which enables the system to be tested without activating selected parts of the system (plant shutdown relays for instance).

When a test mode input is operated, the panel will respond as follows:

ON TEST LED

LCD ON TEST MESSAGE, ADDRESS AND LOCATION TEXT OF INPUT

### 18.3. Outputs

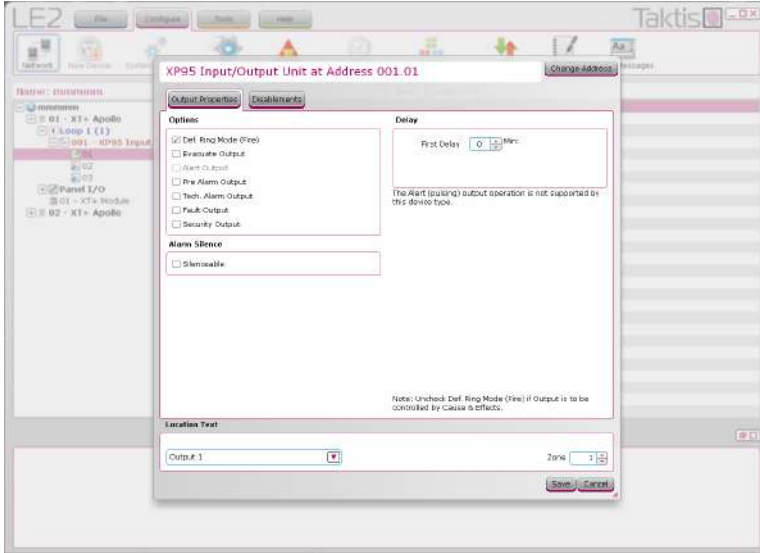

Control of outputs uses the same philosophy as that described for inputs, i.e. all outputs are treated the same, whether they are loop controlled relays, loop sounders, sounder controllers, panel sounder outputs, panel programmable relays, remote I/O board outputs or the panel mounted programmable LED indicators.

Any output can be given a set of attributes, which defines, how the output will respond to input conditions.

Although this may appear to be nonsense in some cases, (a loop controlled sounder which doesn't operate upon a fire condition in its own zone for instance), this approach does provide a simplicity of understanding and a versatility and flexibility which would not exist if there were a different set of rules for each output.

There are default attributes for all types of output, which are factory set and will not change unless re-configured. This ensures that panel sounder outputs, bell controllers and loop sounders for instance, will respond to fire conditions unless the configuration for these outputs is deliberately changed.

NOTE – When configuring system outputs, care should be taken to ensure that the output operation conforms to the local fire regulation requirements.

The editable attributes are as shown in this screen capture from the PC configuration programme.

The following describes how each of these attributes affects the operation of the output.

#### 18.3.1. Evacuate Output

An evacuate output will turn on continuously when any evacuate input is operated. This normally applies to sounders and would normally be accompanied by the Def. Ring Mode and Silenceable attributes.

**Note: Any output on the Syncro AS system is treated as a sounder if the Silenceable and Evacuate Output attributes are selected. If any of these outputs are faulty or disabled, the sounder fault/disabled indicator will illuminate. These outputs would also be disabled by the 'Disable all sounders' menu option.**

### 18.3.2. Def Ring Mode.

Normally applicable to sounders, Def. Ring Mode will turn the output on, upon a fire condition as defined by the global default ring mode set on the Panel Settings page of the PC configuration programme or as set via the Edit Configuration menus on the panel.

There are three options for Def. Ring Mode:-

Common Alarm - All outputs operate continuously regardless of which zone they are in.

Zoned Alarm - Outputs in the same zone as the input, which caused the alarm, will operate continuously.

2 Stage Alarm - Outputs that are in the same zone as the input which caused the alarm will operate continuously whilst outputs in all other zones will pulse 1 second on - 1 second off.

The factory default setting for the panel Default Ring Mode is Common Alarm. This normally applies to sounders and would normally be accompanied by the Evacuate and Silenceable attributes.

Note: When controlling outputs using cause & effects the def ring mode should be de-selected to ensure that the output is only controlled by the cause and effect logic.

### 18.3.3. Silenceable

Silenceable is normally applicable to sounder outputs and ensures that the output switches off when the alarm is silenced/acknowledged by the front panel pushbutton or operation of an input that is configured as an Ack. Alarm (Acknowledge Alarm) input .

**Note: Any output on the Syncro AS system is considered as a sounder if the Silenceable and Evacuate Output attributes are selected. If any of these outputs are faulty or disabled, the sounder fault/disabled indicator will illuminate. These outputs would also be disabled by the 'Disable All Sounders' menu option.**

### 18.3.4. Alert

An alert output will pulse on and off when any alert input is operated. This normally applies to sounders and would normally be accompanied by the Def. Ring Mode and Silenceable attributes i.e. a sounder output. Note: Some devices do not support pulsing outputs.

### 18.3.5. Stage one delay

Outputs can be delayed from 0 to 5 minutes in half-minute steps by changing the default delay of zero to the desired time delay setting.

### 18.3.6. Stage two delay

If the output is silenceable, the stage two-delay option becomes available. The stage two delay gives an additional time before the output operates after the alarm is acknowledged during the stage one delay.

**Note: Care must be taken when configuring outputs with a combination of delays to some outputs and no delays to other outputs. To start the Stage two delay, the Silence Alarm/Acknowledge button must be pressed during the Stage one delay period. If outputs elsewhere on the system are configured with no output delays and are also configured as silenceable, then these outputs will be silenced when the stage one delay is acknowledged.**

**In the majority of systems, the delays to outputs are configured to all sounder outputs to allow a variable search time and therefore this comment is not applicable.**

### 18.3.7. Zoning

Each output can also be put into a zone or not as required. It is useful to put outputs into zones if the output is required to respond to default ring mode or is to be controlled by a cause and effect entry.

Outputs that are not put into a zone and are configured to respond to default ring mode will always turn on with any fire condition (i.e. common alarm). Care should be taken to ensure that no more than 32 devices should be affected by a single short or break in any detection circuit.

### 18.3.8. Location text

Finally, each output can be given a location address. As well as being useful in identifying devices with monitored outputs and additional power, for fault conditions, the location address can be useful in identifying the device when compiling cause and effects programmes.

### 18.3.9. Tech alarm

A Tech alarm output will turn on continuously when any Tech alarm input is operated.

### 18.3.10. Pre-alarm

A pre-alarm output will turn on continuously when any pre-alarm input is operated.

## 19. Cause and effect programming

For more complex applications, it is often a requirement to control plant, ventilation or access control systems in the event of fire situations to assist with evacuation or to provide safety escape routes.

Because the Syncro AS system has inherent flexibility, this is simple to achieve by applying cause and effects to inputs and outputs anywhere on the system.

Cause and effects can be started or acted upon by any part of the system not just the detection loop or control panel but by both of these and by the additional I/O modules too.

It is also network wide. Any part of the system can contribute to a cause and effect action and similarly any output can be operated by an input or any combination of inputs.

With careful planning, this can save costs on installation by reduced wiring runs and can be changed at any time to suit changes in requirements.

Cause and effect programming requires the Loop Explorer 2 software (which will run on a Windows ® compatible computer) and a download lead to transfer the data to the control panels.

Using cause and effect programming it is possible to combine inputs or zones using logical operators, to operate on outputs in any manner desired.

It should be noted here however that when using zonal cause and effects the system will act upon fire inputs in the zone of activation only. Inputs in the selected zone that are not configured as fire event type will not contribute to a zonal cause and effect.

Cause and effects can also be used to disable any outputs or groups of outputs in response to the chosen input conditions. This is particularly useful where normal operation of the fire system requires regular intervention by the end user as switches can be provided anywhere on the system to allow isolations to be performed without operating the control panel.

Also to assist the end user and encourage regular testing, a special "Test Mode" cause and effect facility is included which allows specific parts of the system to be tested without operating sounders or shutting down plant etc. This would normally have to be done by disabling individual outputs at the control panel with the risk of missing something and shutting down an important plant or process.

Full details of cause and effect programming are included with the Loop Explorer 2 software, which also allows full system configurations to be created and downloaded to individual or an entire network of control panels using a simple graphical user interface.

**NOTE** – When configuring the system using cause and effects, care should be taken to ensure that the system operation conforms to the intended design and local fire regulation requirements.

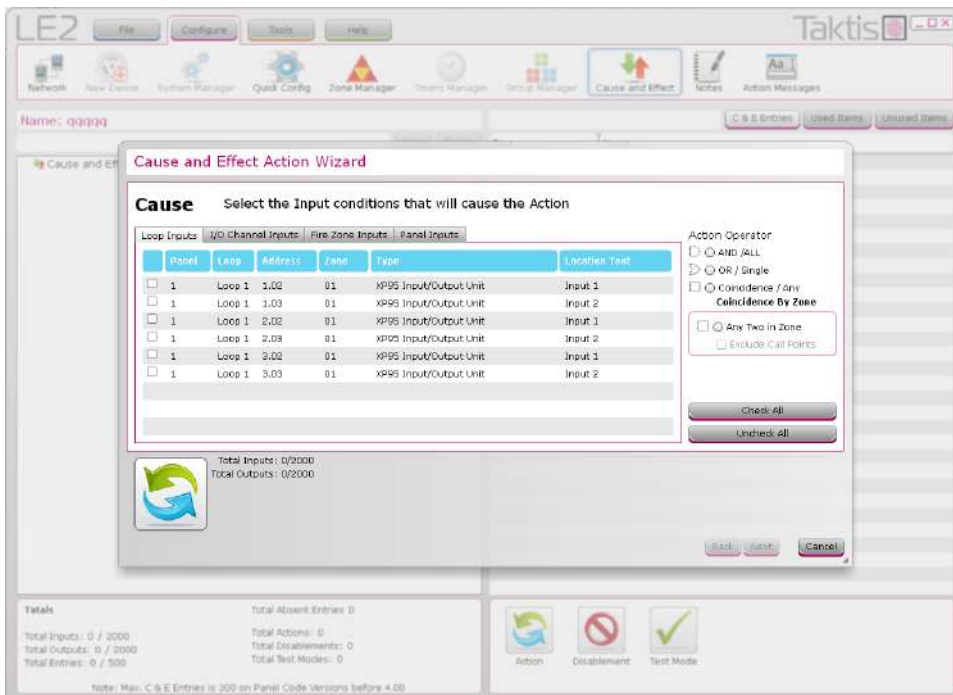

## 20. Extinguishing module configuration

Double clicking on an extinguishing module in the left hand tree in Loop Explorer 2 allows the module to be configured with a number of attributes.

The module can be allocated a name of up to 15 characters.

The first and last activation zones can be set in the range 1 to 500.

The module address can be changed in the range 1 to 32. The address switches on the modules fitted to the panel must match these.

Other attributes that can be set in Loop Explorer 2 are on 3 tabs as follows:

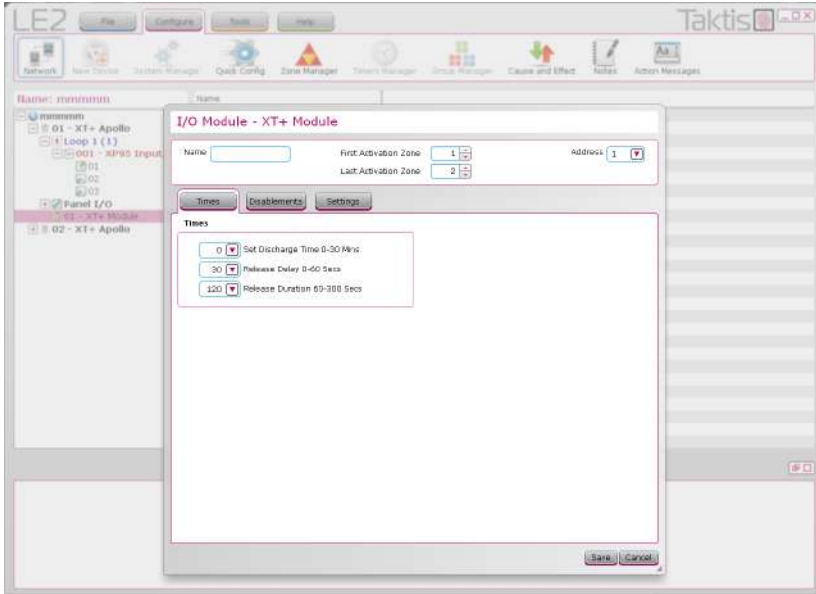

### 20.1 Times tab

#### 20.1.1 Discharge time

It is a requirement of the extinguishing control panel standard EN12094-1 to inhibit reset of the system after it has been activated until there is a signal representing the end of the discharge (a released input) or for an adjustable time period of up to 30 minutes. The factory default for the reset inhibit time is 0.

A drop down control allows this to be set from 0 to 30 minutes in 1 minute steps.

#### 20.1.2 Release Delay

The delay between activation of a module and operation of the extinguishing outputs can be set to between 0 and 60 seconds in 1 second steps. The default is 30 seconds.

#### 20.1.3 Release Duration

The length of time the extinguishing outputs are operated can be set to between 60 and 300 seconds in 10 second steps. The default is 120 seconds.

### 20.2 Disablements tab

#### 20.2.1 Release Timer

The release timer can be disabled such that once the extinguishant outputs have operated; they remain operated until the system is reset.

#### 20.2.2 Earth Fault monitoring

Earth fault monitoring is permanently disabled on embedded modules, i.e. those fitted as part of the combined CIE/ECD panel because earth fault monitoring is carried out elsewhere in the system. However, earth fault monitoring is enabled on remote modules connected to the CIE serial bus and can be disabled on these modules if required.

#### 20.2.3 Fault Output

The fault relay on each module can be disabled.

### 20.3 Settings tab

#### 20.3.1 Stage Two Alarms

The second stage alarm output on the module that is normally pulsing can be set to activate steady.

#### 20.3.2 Release Indication

The released condition, normally asserted upon receipt of an input from a pressure switch, can be asserted as soon as the extinguishing release outputs operate on systems where no release pressure switch is available.



### **20.3.3 Release Pressure Switch Mode**

It is possible to invert the action of the Release Pressure Switch input for instances where only a normally closed Pressure Switch is available.

This facility should be used with caution as it is difficult to set up without putting the module into the released condition and activating the seconds stage alarm and contacts.

### **20.3.4 Pre-Release Delay on Manual Activation**

For instances where an instant extinguishant release is required when a Manual Release input is activated, the Pre-Release delay can be switched off.

### **20.3.5 R0V Removed on Reset**

The Aux24V output supply can be configured such that the R0V (negative) is removed for around 5 seconds when the panel is reset. This is typically used to reset ancillary items such as beam detectors which need a power cycle to reset them. The default is for R0V not to be removed when the panel is reset.

### **20.3.6 Low Pressure Switch Mode**

It is possible to invert the action of the Low Pressure Switch input. The default is for this inputs action not to be inverted.

### **20.3.7 Language**

Some modules are factory fitted with an alternative language to English. The alternative language can be used by selecting Other. The default language will be English.

### **20.3.8 Output Mode**

The two extinguishing outputs normally operate in parallel, at the same time. It is possible to set the outputs to operate in Main/Reserve mode such that when the system is activated, only output 1 operates and a Main/Reserve selection option appears at access level 2. When reserve is selected at access level 2 the Reserve Cylinders indicator on the module will be lit and subsequent activations will cause only extinguishing output 2 to operate.

### **20.3.9 Activation Mode**

The activation mode is set to coincidence by default such that any 2 zones of the configured Activation Zones will cause the module to enter the activated condition when these zones are active. By selecting Single, any single zone of the selected activation zone range will cause the module enter the activation condition when a zone is active. The default is Coincidence.

### **20.3.10 User Output Mode**

It is possible to change the function of the Stage 1 relay contact such that it will operate upon a Hold condition rather than a pre-activated (Stage 1) condition.

The default is that this relay contact operates at stage 1, pre-activated condition.

## 21. Networking

It is possible to connect control panels such that information can be shared between them and for control panels to operate outputs on other control panels in response to alarm conditions or cause and effects configurations.

Syncro XT+ panels may be networked to other Syncro XT+ panels, Syncro AS panels and Syncro panels but not, single area Syncro XT (A65XXX series) panels or any panels fitted with Argus Vega protocol.

**NOTE:** The Syncro and Syncro AS panels must have the same firmware installed as the Syncro XT+ panel, to ensure full compatibility. It may be necessary to update the firmware on the Syncro / Syncro AS panels to achieve this.

To do this, each panel must be fitted with a networking board, which plugs onto the main display board into connectors X7 and X8 on single loop panels or onto the loop 2 board on 2 loop panels.

To fit a networking board, the panel must have both its mains and battery power removed.

The PCB chassis should be removed from the enclosure by removing the two fixing screws holding it in place.

Remove the screws and washers from the two fixing pillars located in the network boards fitted position on the left side of the chassis looking at it from the back.

Locate the network board over connectors X7 and X8 and push the board firmly into place until it is fully located in the connectors. Fit the screws and washers through the two holes in the network board and into the fixing pillars to hold the board in place.

The PCB chassis can then be fixed back into the enclosure and held in place by the two fixing screws removed earlier.

Each control panel has two pairs of terminals on the terminal board for connection of the network cable in and out. It is recommended that a cable such as Belden 9841 suitable for transmission of EIA RS-485 data be used.

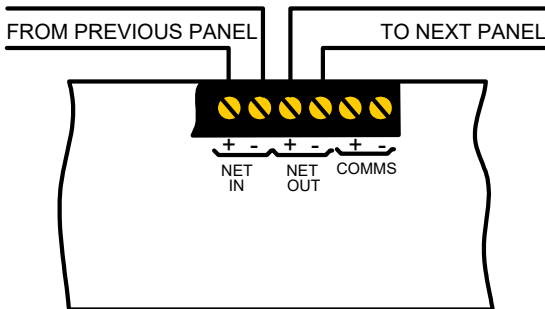

The network connection must come into each panel on the "Network In" terminals and go to the next panel on the "Network Out" terminals, returning to the first panel "In" from the last panel "Out" terminals.

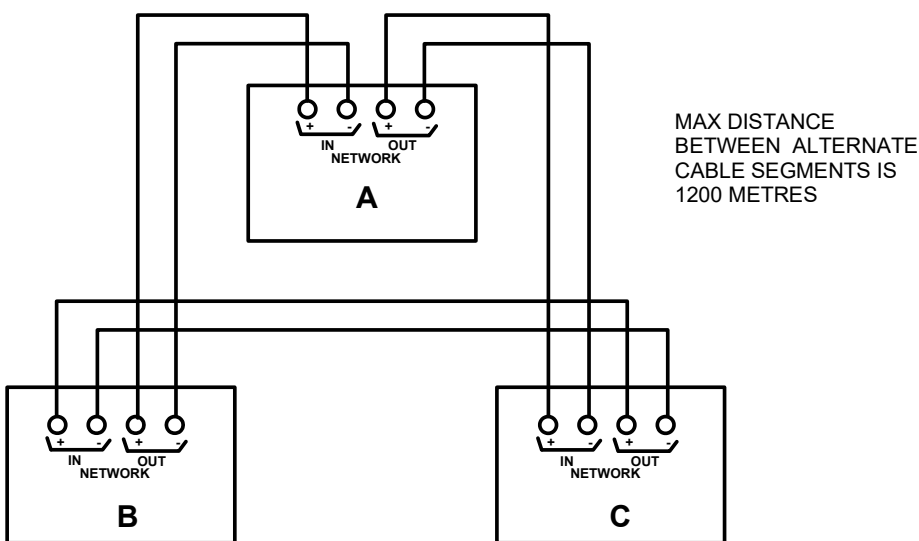

Network boards are fitted with isolators, which disconnect faulty sections of cable and allow the network to continue working by using the return path so it is most important that this wiring configuration be adhered to.

A more detailed description of networking capabilities can be found in the Syncro AS Networking Manual.

## 23. Panel Settings

### CIE

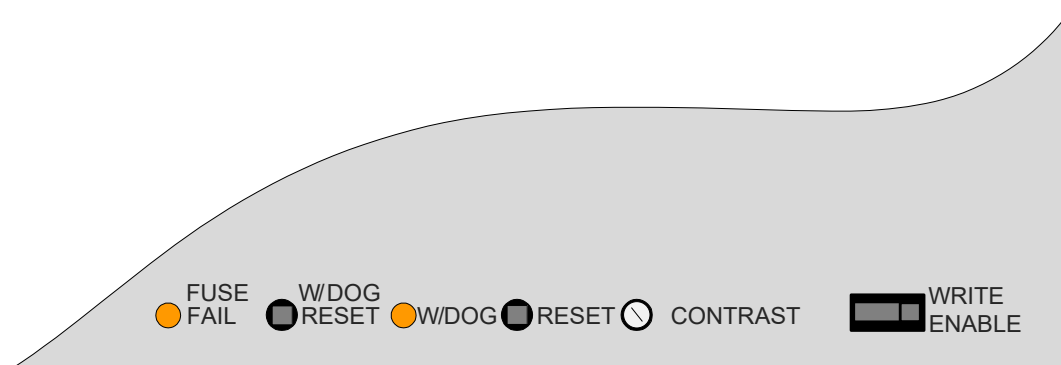

#### 23.1. Write Enable switch

The Write Enable switch must be ON whenever the configuration of the system is to be changed. It is set to the ON position by sliding gently to the left. The Write Enable switch must be turned OFF when configuration is completed or the panel will report a fault condition.

#### 23.2. Contrast Adjust

The viewing angle/contrast of the Syncro AS front panel display may be adjusted by turning the CONTRAST adjust potentiometer. The contrast adjust potentiometer can be accessed by opening the front cover of the control panel and is labelled CONTRAST.

#### 23.3. Reset switch

The main processor can be Reset by operation of this reset switch. When the processor is reset the panel will go through its entire start up and initialisation procedure which may take several minutes.

#### 23.4. W/DOG indicator

The watchdog indicator is lit if the processor has re-started due to an abnormal operation. This is typically due to some sort of extreme and abnormal event such as a lightning strike in close proximity.

#### 23.5. W/DOG REST switch

If the watchdog indicator is lit it can be reset by operation of the W/DOG reset switch rather than by having to reset the processor and wait for start up and initialisation.

#### 23.6. FUSE FAIL

This fuse fail indicator shows that the primary supply has failed. The system may continue to operate on battery power for a while but this is a serious condition that requires immediate attention.

### 23.7. Network address setting

If there is more than one panel on the system, or the panel is communicating with a network repeater panel, then a network card will need to be installed within each panel in the network. Each panel will need to be allocated separate network address identification. This is performed by use of a binary coded DIL switch on the network card.

The network card is fitted to the back of the main PCB. The plate to which the main PCB is attached must be removed from the control panel to access the address switch.

Turn off the mains power and disconnect the batteries before removing the plate from the panel. Remove the two fixing screws that hold the plate in position and store them safely so that they can be replaced.

Turn the plate upwards towards the top of the enclosure to expose the network card and address DIL switch. Set the required binary address on the network card DIL switch.

Put the plate back into its original position and fix with the two screws that were previously removed.

After a network card has been added, it will be necessary to auto configure the panel, to clear the "unexpected network card" fault message. This action will also save the panel address in non-volatile memory and allow the site configuration file to be transferred to the panel at the set address.

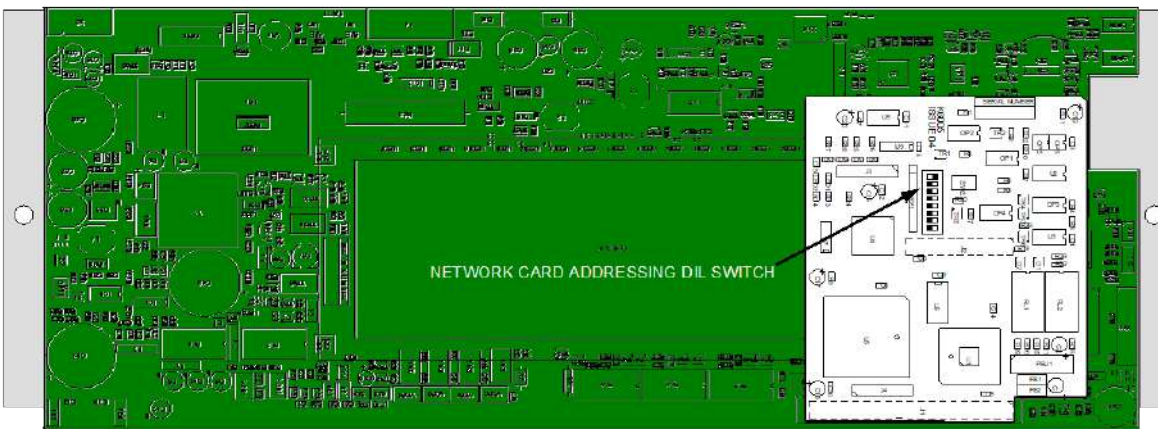

### ECD

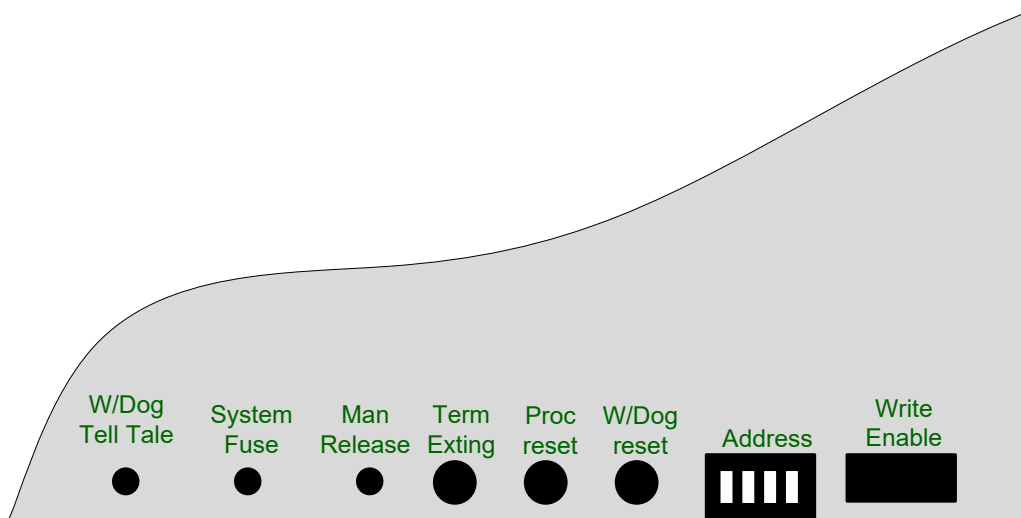

### 23.8. Write Enable

The Write Enable switch must be ON to enter access level 3. It does not need to be ON to enable the system to be configured via the Loop Explorer 2 configuration programme. It is set to the ON position by sliding gently to the left. The Write Enable switch must be turned OFF when access level 3 is no longer required or the panel will report a fault condition.

### **23.9. Address**

The address of the extinguishing module must be set in the range 1 to 32 and each module on a system must have a unique address. On an autolearned system the address of the module will determine its default activation zones with address 1 being activated by zones 1 & 2, address 2 being activated by zones 3 & 4 and so on.

### **23.10. W/DOG REST switch**

If the watchdog tell tale indicator is lit it can be reset by operation of the W/DOG reset switch rather than by having to reset the processor.

### **23.11. Proc Reset switch**

The main processor on the module can be Reset by operation of this reset switch.

### **23.12. Term Exting switch**

Active extinguishing outputs can be terminated by operation of the Term Exting switch. This function may be useful when testing on a system that has a lengthy discharge time set rather than having to wait for the discharge timer to complete to carry on testing the system.

### **23.13. Man release indicator**

This indicator is lit whenever a manual release (panel mounted or remote) has been operated and will only be extinguished when the Proc Reset switch is operated.

### **23.14. System Fuse indicator**

This fuse fail indicator shows that the primary supply has failed. The system may continue to operate but this is a serious condition that requires immediate attention.

### **23.15. System Fuse indicator**

This fuse fail indicator shows that the primary supply has failed. The system may continue to operate but this is a serious condition that requires immediate attention.

### **23.13. W/Dog tell tale indicator**

The watchdog indicator is lit if the processor has re-started due to an abnormal operation. This is typically due to some sort of extreme and abnormal event such as a lightning strike in close proximity.

## 24. Panel specification summary

### 24.1. Recommended cables

All field wiring should be installed using fire rated cables such as FP200, MICC or Fire Tuff types. The minimum cross sectional area should be 1mm although in the case of the detection loops this depends upon the length of the cable and the number and type of devices fitted. Loop length calculators for various cable types are available for both Hochiki and Apollo protocol systems. Drain wires of any field wiring should be maintained throughout the length of the cable and terminated at the panel via brass cable glands. Refer to [Section 5.1](#) for loop earth termination requirements.

### 24.2. Sounder Load

Panel Sounders CIE - Two 24 volt sounder circuits, each rated at 500 milliamps and fused with a 1.0A self-resetting electronic fuse. Each sounder circuit is monitored using reverse polarity and a 10k ohm end of line resistor. Loop sounders – each loop is capable of delivering up to 400mA for devices and loop sounders & beacons.

**The total monitored output load (loop & panel sounders, & aux 24V output) must not exceed 2.5 Amps.**

### 24.3. Current consumption

1 loop panel current consumption	130mA (power fault) 300mA in alarm (no alarm load)
2 loop panel current consumption	195mA (power fault) 370mA in alarm (no alarm load)
Extinguishing module current consumption	45mA (power fault) 220mA in alarm (no alarm load)
Network card current consumption	60mA
I/O board current consumption	20mA (quiescent), up to 1A in full alarm
8 way relay card current consumption	10mA (quiescent), 250mA in full alarm
6 way sounder card current consumption	30mA (quiescent), 260mA in full alarm + sounder load
4 way zone board current consumption	70mA (quiescent), 250mA in full alarm
Sigma SI status unit	70mA (quiescent)
Sigma XT ancillary board	25mA (quiescent), 125mA in full alarm

### 24.4. Power supply –

Supply Voltage	230V AC nominal (+10% / 15%)
Supply rating	5.25 Amps.
Battery Charger	Charges up to 26Ah sealed lead acid batteries with temperature compensation over the range -5 to +50 degrees Celsius.
Battery Type	Two 12V sealed lead acid, up to 15Ah (12Ah package) fit inside panel
Output current split	Battery 1.25 Amp max, load 4 Amps.
Battery low indication	21V,
Earth fault indication	< 30Kohms +28V or 0V to earth.

### 24.5. Field devices

Hochiki	127 devices per loop- ESP protocol
Apollo	126 devices per loop - S90, XP95, Xplorer and Discovery ranges.
Per 1 loop panel	127 Hochiki ESP devices, 126 Apollo devices.
Per 2 loop panel	254 Hochiki ESP devices, 252 Apollo devices.
Sub-address total	800 addresses and sub-address limit per panel.

### 24.6 Relay ratings

All panel relay contacts are rated at 30V DC and 1 Amp maximum. Under no circumstances should voltages or currents outside of these limits be connected.

### 24.7 Zones

All models have 16 zonal LED indicators fitted. Any device can be configured to any one of 500 zones available across all panels on the network. Care should be taken to ensure that no more than 32 devices will be affected by a single short or break in any detection circuit.

### 24.8 Networking

Up to 64 Syncro XT+, Syncro AS or Syncro control panels can be connected together using an RS485 type cable with a maximum distance (without boosters) of 1.2Km between alternate cable segments. An additional network PCB is required in each panel to achieve this.

Repeaters (full functional and display only) each take a single address from the 64 available network addresses.

Refer to Networking Manual MAN-1058 for more details.

## 24.9 Remote Control Inputs (see also Section 15)

Unmonitored digital inputs, activated when connected to the Remote Control 0V terminal with an in line resistance of less than 50 ohms.

Note: Remote control inputs must be restricted by the Access level requirements of EN54-2. Therefore it should not be possible to remotely reset, silence or operate the alarm devices without some means of gaining access to this function.

## 24.10 Auxiliary 24 Volt monitored output (see also Section 17.1)

Permanent 24 volt output protected by a 500mA self-resetting electronic fuse, monitored for fuse failure.

## 24.11 Fuse ratings

All panel power supplies, monitored outputs and auxiliary power outputs are protected by non-serviceable self resetting electronic fuses.

Detection circuits are protected using digital current monitoring circuits and FET switching techniques.

The Syncro XT+ panel has a serviceable fuse to protect the incoming mains supply. This fuse is a T3A 250HRC 20mm type and must be replaced with a fuse of the same type only.

## 25. Additional features

### 25.1. Loop Data Test

The data signalling between the control panel and detection devices has some level of data error checking built into the protocol. The purpose of this data checking is to ensure that any spurious signals received by the control panel are not incorrectly interpreted as fire signals, thus avoiding an unwanted activation. Information received at the control panel that is not exactly as it is expected to be is known as bad data.

There are a number of sources of signalling errors. The most common is due to electrical interference resulting in current spikes induced on the detection circuit. Other possible causes are poor loop wiring connections, earth leakage between loops, cross-talk between circuits, defective devices installed on the detection circuit and incorrect devices connected on the detection circuit. Excessive loop resistance is the cause of many bad data faults. These tend to be from devices located nearest the Loop In terminals. If loop resistance is suspected, swap the loop in and loop out cables and see if the bad data faults start occurring from devices fitted at the other end of the loop.

Also excessive Loop Sounder Current will cause bad data faults to occur when the sounders are operated

In general, the user is unaware of problems on the detection circuit, as the panel has some "software filtering" built in, to reject invalid data returned from devices. However, if a single device returns invalid data on four consecutive polls, the panel will report a bad data fault for that device. If a single device returns invalid data for three polls, followed by a single good poll, then the panel will report no faults for that device.

The purpose of the system diagnostics facility is to see what level of invalid data signalling is occurring on the loops, to get a "feel" for the quality of the signalling and to predict any potential problems that may affect the end user.

The diagnostics facility comprises of two counters for each loop. These counters have a maximum value of 9,999,999. There is a "good" counter, which is incremented for every successful detection device poll and a "bad" counter, which is incremented every time there is an error in the signalling when a device is polled.

This good/bad counter selection allows an engineer to see the proportion of bad readings versus good readings, and compare these between loops for a system. From this information, it should be possible to make a judgement on the signalling quality for each detection circuit on any control panel.

To activate the diagnostics, select the Loop Data Test menu option at Access Level 3. This menu will then allow the user to start the testing for each loop in turn. When started, the user may view the good and bad counters, plus the time that the test was started.

At any time it is possible to view the counters or cancel the testing.

When either of the two counters reaches the maximum value, the test for that loop is halted.

### 25.2. Network Panel Menu Control

When Syncro XT+ control panels are connected as a network, it is possible to perform Access 2 Menu commands on remote panels from any panel on the network. This facility is done by use of the UP and DOWN arrow keys to select the network node whenever the Syncro XT+ is installed on a networked system.

#### 25.2.1. Network Disablements

On a networked system, select the access 2 menu from any control panel. Move the selection cursor to be next to the Disablements menu option. Press the right arrow navigation key to choose the menu selection.

The default selection will be the local panel you are using. Use the up / down arrow navigation keys to scroll through available panels, then press the right arrow navigation key to choose the selected panel.

At this point, the standard disablement menu options will be viewed. **These menu options apply to the selected panel, rather than the local panel you are using.**

When selecting disablements, all options are the same as for a standard panel.

### **25.2.2. View Device Details on other panels**

It is possible to view device details for devices connected on remote panels from any panel on a networked system using the View Devices menu option in the Access 2 menu.

Note: When viewing device details on a remote panel, the scrolling and refresh rate will be slower than for devices on a local panel.

### **25.2.3. Global System Time**

Whenever the system time is set on any panel on the networked system, then all panels will be set to this time. This simplifies the process of changing the time for daylight saving on large networked systems.

### **25.3. Configuration Transfer over Network**

Using Loop Explorer 2, it is possible to transfer the configuration to any panel or all panels on the network from a single place. This eliminates the need to go to each control panel in turn to transfer updated configuration files. The write enable switch must be switched on at the target panel before it is possible to transfer a configuration file across the network.

### **25.4. Contamination Status**

The Syncro XT+ control panel calibrates all detection devices every 24 hours, at a time specified by the panel configuration settings.

The calibration procedure checks a number of parameters for each device to ensure that the device will meet the performance specification, as defined by the device manufacturer. If any devices fail to meet this calibration procedure, then the device will be announced as a calibration fault and will need to be replaced.

When devices exceed 85% of their calibration fault limits, they are added to the "Contamination Status" log. At this point, the control panel will not report a fault for the device.

The Contamination Status menu option allows the maintenance engineer to view these devices, to replace them and therefore prevent contamination faults between service calls.

This menu option is available across panels on a networked system, allowing the contamination status for any panel to be viewed from any panel.

### **25.5. Analogue value transfer**

If a connection to the Syncro XT+ panel is made using the "Transfer Configuration" screen of Loop Explorer 2, it is possible to transfer the analogue levels, zero calibration and fire calibration points for each detection device to the PC and save this as a .csv file which can be read by a spreadsheet application.

## **26. Maintenance**

Syncro XT+ control panels do not require any specific maintenance but should the control panel become dirty it can be wiped over with a damp cloth and should then be dried with a dry, lint free cloth. Detergents or solvents should not be used to clean the panel and care must be taken that water does not enter the enclosure.

The control panel contains sealed lead acid batteries to provide standby power in the event of a mains failure. These batteries have a life expectancy of around 4 years. It is recommended that these batteries be tested in accordance with the battery manufacturer's recommendations annually to determine their suitability for continued standby applications.

Routine testing of the fire alarm and extinguishing system should be done in accordance with BS5839: Part 1: 2013 and will identify any malfunction of the control panel. Any malfunction should be reported to the fire alarm maintenance company immediately.

Should the control panel become faulty the complete electronic assemblies can be replaced.

To do this, any configured options should be noted then both mains and battery power should be removed before the work is started.

The field wiring should be carefully labelled and removed from the terminals.

The PCBs can now be taken out of the panel by removing the screws holding the plates in position.

Fitting the new PCB is the reverse of the procedure for removing the board.



## **Appendix A – EN54 Configuration Requirements**

In order to meet the requirements of EN54, the panel must be configured with the settings stated below.

**References refer to EN54 Part 2 1997 clause numbers.**

### **Section 7 – Fire Alarm Condition**

#### **Section 7.1.4**

Input delay must be set to zero for all manual call points. Call points must not be configured to any event type other than Fire.

#### **Section 7.2.c / 7.4 / 8.2.1.c / 8.6**

The panel buzzer must be enabled. The system disablements menu option must not be used.

#### **Section 7.6.1**

The internal "Reset" remote control input must be configured so that it is only available at Access level 2, by use of a key input or some other access restriction.

#### **Section 7.8**

If the panel sounder circuits are to be used to meet the requirement of "transmission of fire alarm signals to fire alarm devices", then the Def Ring, Silence and Evacuate properties must be selected. The sounder circuits must also be mapped to Zone 0.

#### **Section 7.9**

The fire routing output must be set to Zone 0 and to respond to Def Ring mode only.

#### **Section 7.11**

Care must be taken when configuring outputs with a combination of delays to some outputs and no-delays to other outputs.

To start the Stage two delay, the Silence Alarm / Acknowledge button must be pressed during the Stage one delay period. If outputs elsewhere on the system are configured with no output delays and are also configured as silenceable, then these outputs will be silenced when the stage one delay is acknowledged.

#### **Section 7.11.a**

To select delays to outputs at access level 3, use the Edit Configuration / Edit Panel I/O / Panel Outputs to select the sounder outputs. Select the output and configure the 1<sup>st</sup> stage delay to the required amount.

#### **Section 7.11.d**

All call points must be configured with the "Bypass delay" attribute set.

#### **Section 7.12.3 – Type C Dependency Programming**

In order to meet the EN54-2 requirements for Type C Dependency Programming, the following cause and effects is required to configure a particular zone for Type C Dependency.

- The cause and effect has all detection devices and/or call points in the required zone selected (by address) and the 'COINCIDENCE' logical operator used to switch the required outputs in the effect screen.
- An alternative to the above is to use a cause and effect with the zone selected and with the "coincidence by zone – any two in zone" logical operator. The option to "exclude call points" is provided.
- All outputs controlled by the above cause and effect must have the Def Ring output flag deselected to ensure compliance

### **Section 8 – Fault Warning Condition**

#### **Section 8.2.4.c**

Earth fault monitoring must be enabled. The system disablements menu option must not be used.

#### **Section 8.8**

The fault relay output must be configured to respond only to fault events.

### **Section 9 – Disabled Condition**

#### **Section 9.1.2**

If a disablement input type is used as the cause a disablement cause and effect, this input must be configured so that it is only available at Access level 2, by use of a key input or some other access restriction.

#### **Section 9.1.4**

If a disablement input is used as a cause for a disablement cause and effect, this input must be configured to be non-latching and should not reset when the system reset is selected. It can only be cleared by a manual action at access level 2.

### **Section 10 – Test Condition**

#### **Section 10.1.b**

If a test input type is used as the cause in a test mode cause and effect, this input must be configured so that it is only available at Access level 2, by use of a key input or some other access restriction. This input must be configured as non-latching and can only be cleared by a manual operation at access level 2.

## Section 12.5 – Integrity of Transmission Paths

### Section 12.5.2

A short circuit isolator must be fitted to the detection circuit at a maximum interval of 32 detection devices and manual call points.

## Section 12.6 – Accessibility of indications and controls

### Section 12.6.6

The panel door must be locked and the key removed.

<b>Kentec Electronics Ltd.</b> <b>Dartford DA1 1JQ U.K.</b> 2797 CPR 496748		<b>CE</b> 0086
<b>EN12094-1</b> Electrical automatic control and delay device. Environmental Class A. Flooding Zones 1-4. CO2-low-pressure, inert gas systems. <b>Provided options:</b> - Delay of extinguishing signal. - Signal representing the flow of extinguishing agent. - Monitoring of the status of components. - Emergency hold device. - Emergency Abort device. - Extinguishing signals to spare cylinders. - Triggering of equipment outside the system. - Activation of alarm devices with different signals. Response delay activated condition maximum 3 sec. Response delay triggering of outputs maximum 1 sec. Install in accordance with Operation and Maintenance manual Man-1197. <b>Disconnect power before servicing.</b>		
Works Order No:	<input type="text"/>	
Model number:	<input type="text"/>	
Date of manufacture:	<input type="text"/>	
Power rating: 230V AC 1A 50Hz. Mains terminal fuse F3A 250V TD 20mm		
Lab-1806 B4593		