

Instructions

Det-Tronics SmokeWatch™ Explosion Proof Smoke Detector
U5015



Table of Contents

OVERVIEW	1	INSTALLATION	5
FEATURES	1	Grease / Lubrication	5
BENEFITS	1	Identification of Detector Mounting Locations	5
SPECIFICATIONS	2	Protection Against Moisture Damage	6
OPERATION	3	Power Supply Requirements	6
Warm Up	3	Transport Cover	6
Outputs	3	Mounting Location Options	6
Integral Wiring Compartment	4	Mount the Detector	7
LED	4	Wiring Cable Requirements	7
Latching	4	Jumper	7
Non-Latching	4	Wiring Procedure	8
Continuous Self-Test	4	MAINTENANCE	9
Manual Self-Test	4	Routine Inspection	9
IMPORTANT SAFETY NOTES	5	DEVICE REPAIR AND RETURN	13
		ORDERING INFORMATION	13
		Spare Parts	13
		Accessories	13
		U5015 Model Matrix	13
		APPENDIX A – FM APPROVAL DESCRIPTION	14
		APPENDIX B – CSA APPROVAL DESCRIPTION	15
		APPENDIX C – IECEX APPROVAL DESCRIPTION	16
		APPENDIX D – ADDITIONAL APPROVALS DESCRIPTION	17

Det-Tronics SmokeWatch™
Explosion Proof Smoke Detector
U5015

 **WARNING**

Be sure to read and understand the entire instruction manual before installing or operating the smoke detection system. Any deviation from the recommendations in this manual may impair system performance and compromise safety.

OVERVIEW

The Det-Tronics SmokeWatch™ U5015 Explosion Proof Smoke Detector has Division and Zone explosion-proof ratings and is suitable for industrial and commercial applications. The detector is designed to operate effectively with smoldering and rapidly growing fires and contains the ability to annunciate faults ensuring no undisclosed failures. The SmokeWatch U5015 Smoke Detector outputs include 0-20 mA, a localized LED, and relays.

Typical applications that use the U5015 include:

- Combustible storage facilities
- Munitions manufacturing
- Volatile chemical storage
- Chemical processing plants
- Petroleum refineries
- Turbine enclosures
- Battery rooms
- HVAC applications

The hot-swappable sensor module is intrinsically safe and allows live maintenance while under power, without de-classifying the hazardous area. The integrated junction box is available in a variety of port configurations for simplified wiring and installation. See Figure 1 for all the U5015 Smoke Detector components.

**FEATURES**

- FM Approved for use in Class I, Division 1 hazardous locations
- FM Approved for smoke detection performance
- IECEx Zone approved
- Trouble-free photoelectric operation
- 0-20 mA output for DCS integration
- Self-checking circuitry ensures reliable smoke detection
- Alarm, Auxiliary, and Fault relays for controlling annunciating devices or fire panel interface
- LED provides a visual indication that an alarm has occurred
- IP44 ingress protection level suitable for onshore or offshore requirements

BENEFITS

- Ideally suited for classified areas in the petrochemical, oil, and gas industry
- DCS, PLC, integration with milliamp or relay outputs
- Rugged design for environmental extremes
- Visual confirmation of detector alarm
- Detects smoldering fires
- No undisclosed failures

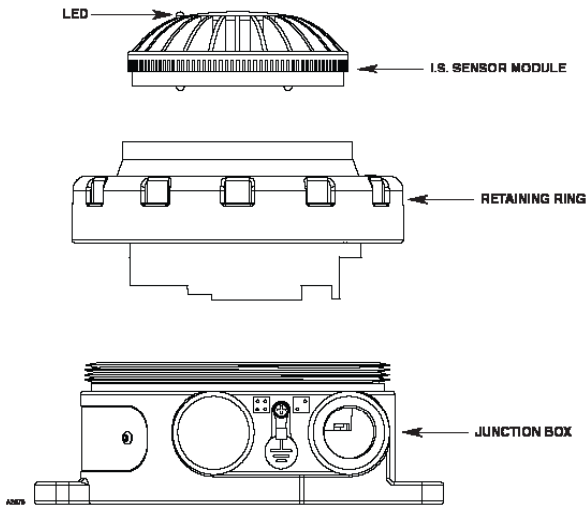

Figure 1—U5015 Components

SPECIFICATIONS

OPERATING VOLTAGE—
12-30 Vdc (24 Vdc nominal)

SMOKE DENSITY—
1.5% - 2.5% obscuration per foot.
(4.9% - 8.2% obscuration per meter).

POWER CONSUMPTION—
3.5 watts maximum (2.75 Watts at 24 Vdc)
0.674 Watts with no relays energized.
1.23 Watts with one relay energized.
2.12 Watts with two relays energized.
2.68 Watts with three relays energized.

OUTPUT RELAYS—
Smoke alarm relay. Form C, 5 amperes at 30 Vdc:
The smoke alarm relay has normally open/ normally closed contacts and normally de-energized operation.

Fault relay. Form A, 5 amperes at 30 Vdc:
The fault relay has normally open contacts and normally energized operation.

Auxiliary relay. Form C, 5 amperes at 30 Vdc:
The auxiliary relay has normally open/normally closed contacts and normally de-energized operation.

TEMPERATURE RANGE—
Operating: -20°C to +65°C (-4°F to +149°F)
Storage: -55°C to +70°C (-67°F to +158°F)

HUMIDITY RANGE—
5 to 95% relative humidity.

INGRESS PROTECTION—
IP44
Note: Applicable to ceiling mount only

CURRENT OUTPUT—
0-20 mA (± 0.3 mA) dc current, with maximum loop resistance of 300 ohms from 12-17.9 Vdc, 500 ohms from 18 to 19.9 Vdc, and 600 ohms from 20-30 Vdc.

TERMINALS—
UL/CSA rated for 14-18 AWG or 2.5-0.75 mm² wire.

THREAD OPTIONS—
3/4 inch NPT or M25.
Multi-port models available.

ENCLOSURE MATERIAL—
Polycarbonate / ABS - Smoke Detector.
Copper-free aluminum (painted) - Junction Box

SHIPPING WEIGHT (Approximate)—
7.85 lbs (3.56 kg).

WARRANTY PERIOD—
1 year.

DIMENSIONS—
See Figure 2.

CERTIFICATION—
For complete approval details, refer to the appropriate Appendix:



OPERATION
WARM UP

When the detector is initially powered up, a warm-up period of one – two (1-2) seconds is allotted for internal checks and communication. During this time, the LED is off and the current level is 3 mA. After the checks are completed, normal operation will be indicated by the LED flashing every four seconds (current level is 4 mA).

If the detector is unable to reach the normal operating mode, the warm-up period may extend to five seconds, followed by a critical fault or an advisory fault (see Table 1 for all current levels). If the problem persists, check for any loose wiring connections, ensure that the voltage supply is sufficient, and cycle power if necessary.

OUTPUTS
Relays

The U5015 detector is furnished with smoke alarm, fault, and auxiliary relays. All three relays are rated to 5 amperes at 30 Vdc.

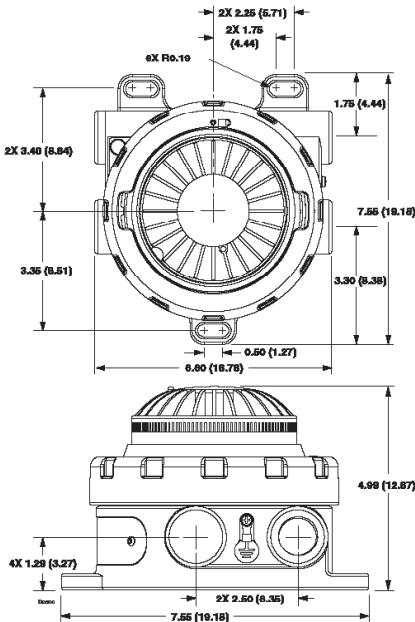

Figure 2—U5015 Dimensions in Inches (cm)

The smoke alarm relay has a single set of terminals and normally open / normally closed contacts, and normally de-energized operation.

The fault relay has a single set of terminals and normally open contacts, and normally energized operation.

The auxiliary relay has a single set of terminals and normally open / normally closed contacts, and normally de-energized operation.

IMPORTANT

The auxiliary relay functions as pre-alarm.

0 to 20 mA Output

The U5015 provides a 0 to 20 mA dc current for transmitting detector status information to other devices. The circuit is wired in a non-isolated configuration and can drive a maximum loop resistance of 300 ohms from 12 to 17.9 Vdc, 500 ohms from 18 to 19.9 Vdc, and 600 ohms from 20 to 30 Vdc. Table 1 defines the current levels and corresponding detector status. The output is calibrated at the factory, with no need for field calibration.

Table 1—Detector Status Conditions

Current Level (±0.3 mA)	Detector Status	Recommended Action
0 mA	Power Fault	Verify 12-30 Vdc is applied to detector
1 mA	Critical Fault	Cycle power. If fault does not clear or returns, replace sensor module or return to factory for service.
2 mA	Power Advisory (<12 Vdc)	Input power at detector is <12 Vdc. Increase power supply to 12-30 Vdc.
3 mA	Warm up	-
4 mA	Normal	-
6 mA	Advisory Fault	Cycle power. If fault does not clear or returns, replace sensor module or return to factory for service.
16 mA	Pre-Alarm	Smoke present at sub-alarm level.
20 mA	Smoke Alarm	-

NOTE

The output of the 0 to 20 mA current loop is monitored by the fault detection circuitry of the U5015. Therefore, an open circuit on the loop will cause the fault relay to change state.

An alarm will normally override a fault, unless the nature of the fault impairs the ability of the detector to generate or maintain an alarm output (i.e., loss of operating power).

INTEGRAL WIRING COMPARTMENT

All external wiring to the device is connected within the integral junction box. The detector is furnished with a maximum of four conduit entries, with either 3/4 inch NPT or M25 threads.

LED

An LED, located on the detector (see Figure 1), indicates normal operation and notifies personnel of an alarm. Table 2 indicates the condition of the LED for each status.

Table 2—Detector Status Indicator

Detector Status	LED Indicator
Power On / Normal Operation	Steady Off 1 blink on every 4 seconds
Alarm	Steady On

LATCHING

A detector configured for latching operation will remain in an alarm state indefinitely, after an alarm occurs.

NON-LATCHING

A detector configured for non-latching operation will check the alarm status of the detector once every 10 seconds. Once smoke falls below the alarm threshold, the alarm annunciation will clear within 10 seconds.

IMPORTANT

The latching or non-latching configuration must be specified during order placement. It is **not** field configurable.

Only the alarm annunciation can be configured for latching operation.

CONTINUOUS SELF-TEST

During normal operation, the detector performs the Self-Test function automatically in the background once per second. During the test, detection is not interrupted and no indication is given if the test passes. If the test fails, a critical fault will occur. If degradation is present and approaching critical levels, an advisory fault will occur.

MANUAL SELF-TEST

The Manual Self-Test function will immediately check the smoke chamber optics for degradation. Once initiated, there will be a one second delay before the result of the check is active. If there is a failure, the LED will shut off immediately after the one second test and a critical fault will occur. If the test passes, an alarm will be annunciated while the LED remains active.

For a latching detector, the alarm will continue until power is cycled to the unit. For a non-latching detector the alarm will clear after 10 seconds. If the test passes, but there is degradation present and approaching critical levels, an advisory fault will occur.

Magnetic Switch

The magnetic switch is used to initiate the Manual Self-Test (see Figure 3). Apply the magnet to the exterior housing and the LED will light to indicate that the magnet is detected. The LED will remain lit for at least one second during the test. After the initial delay, the test status will be indicated as described in the "Manual Self-Test" section.



Figure 3—Location of Magnetic Switch

IMPORTANT SAFETY NOTES

CAUTION

The wiring procedures in this manual are intended to ensure proper functioning of the device under normal conditions. However, because of the many variations in wiring codes and regulations, total compliance to these ordinances cannot be guaranteed. Be certain that all wiring complies with the NEC as well as all local codes. If in doubt, consult the authority having jurisdiction before wiring the system. Installation must be done by a properly trained person.

CAUTION

This product has been tested and approved for use in hazardous areas. However, it must be properly installed and used only under the conditions specified within this manual and the specific approval certificates. Any device modification, improper installation, or use in a faulty or incomplete configuration will render warranty and product certifications invalid.

CAUTION

The device contains no user serviceable components. Service or repair should never be attempted by the user. Device repair should be performed only by the manufacturer.

CAUTION

The U5015 is to be installed in locations where the risk of mechanical damage is low.

LIABILITIES

The manufacturer's warranty for this product is void, and all liability for proper function of the detector is irrevocably transferred to the owner or operator in the event that the device is serviced or repaired by personnel not employed or authorized by Detector Electronics Corporation, or if the device is used in a manner not conforming to its intended use.

NOTE

Observe precautions for handling electrostatic sensitive devices.

NOTE

The U5015 should not be installed in areas in which ammonia, hydrogen sulfide and chlorine are normally present.

INSTALLATION

WARNING

All entries must contain appropriately rated plugs or fittings. It is required that each plug or fitting be wrench-tightened to an appropriate installation torque and meet the minimum thread engagement requirements per the applicable local standards, codes, and practices in order to retain the defined ratings. PTFE sealant or equivalent should be used on NPT threads.

NOTE

Detector housings must be electrically connected to earth ground. Internal and external earth ground terminals are provided. For AEx (United States Zone) installations the internal ground terminal shall be used for the equipment grounding connection. The external terminal can be used for supplementary bonding where local codes permit or require.

NOTE

The U5015 detector uses an internal Intrinsically Safe (I.S.) Barrier. Proper NEC I.S. grounding must be ensured.

GREASE/LUBRICATION

To ease installation and future removal, all threaded covers, stopping plugs, and thread adapters must be installed using thread lubricant. The recommended lubricant is a silicone-free grease, available from Det-Tronics.

For devices with NPT threads, Teflon tape or thread seal lubricant must be used for enhanced sealing capabilities.

IDENTIFICATION OF DETECTOR MOUNTING LOCATIONS

The most effective number and placement of detectors varies depending on the conditions on site. The individual designing the installation must often rely on experience and sound judgment to determine the detector quantity and best locations to adequately protect the area. Note that it is typically advantageous to locate detectors where they are accessible for maintenance.

For additional information on detector location and spacing, visit the National Fire Protection Association's website (www.nfpa.org) and refer to the National Fire Alarm and Signaling Code, NFPA 72, the standard on automatic fire detectors, or your local codes and standards.

PROTECTION AGAINST MOISTURE DAMAGE

It is important to take proper precautions during installation to ensure that moisture will not come in contact with the electrical connections of the system. The integrity of the system regarding moisture protection must be maintained for proper operation and is the responsibility of the installer.

If conduit is used, the use of proper conduit installation techniques, breathers, glands, and seals is required to prevent water ingress and/or maintain the explosion-proof rating.

Conduit drains must be installed at water collection points to automatically drain accumulated moisture. Conduit breathers should be installed at upper locations to provide ventilation and allow water vapor to escape. At least one breather should be used with each drain.

Conduit raceways should be inclined so that water will flow to low points for drainage and will not collect inside enclosures or on conduit seals. If this is not possible, install conduit drains above the seals to prevent the collection of water or install a drain loop below the detector with a conduit drain at the lowest point of the loop.

POWER SUPPLY REQUIREMENTS

Calculate the total detection system power consumption rate in watts from cold start-up. Select a power supply with adequate capability for the calculated load. Ensure that the selected power supply provides sufficient regulated and filtered output power for the entire system. If a back-up power system is required, a float-type battery charging system is recommended. If an existing source of power is being used, verify that system requirements are met.

TRANSPORT COVER

The Transport Cover (see Figure 4) keeps dust and particles out of the smoke chamber that may enter during transport, handling, or installation. It should remain fastened on the detector through the installation process.

IMPORTANT

*Remove the cover **only** after installation is complete and prior to powering the detector for the first time.*



Figure 4—U5015 Transport Cover

MOUNTING LOCATION OPTIONS

Ceiling Mount

The U5015 is intended for surface mounting. It is normally mounted on the ceiling no less than six inches from a side wall (See Figure 5). The exact location of the detector must be determined by an evaluation based on engineering judgement, or if possible, by field tests.

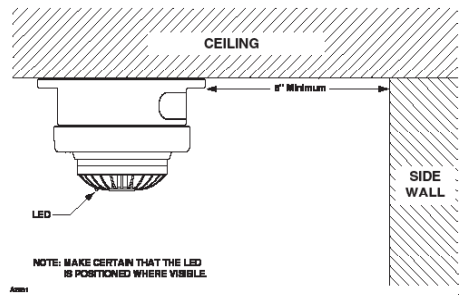

Figure 5—U5015 Ceiling Mount

Wall Mount

The U5015 can also be mounted on a side wall (see Figure 6). The exact location of the detector must be determined by an evaluation based on supplemented engineering judgement, or if possible, by field tests.

IMPORTANT

Whenever possible, select a mounting orientation where the LED is visible to personnel within the area.

MOUNT THE DETECTOR

Using three No. 8 flat head screws (or equivalent)

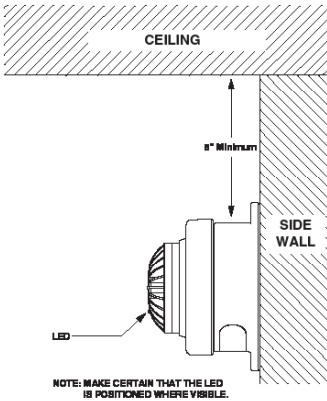

Figure 6—U5015 Wall Mount

placed through the counter bored holes in the detector flange, secure the detector junction box to the surface location.

WIRING CABLE REQUIREMENTS

Always use proper temperature rated cabling type and diameter for input power as well as output signal wiring. 14 to 18 AWG (.75 - 2.5 mm²) shielded stranded copper wire is recommended.

The field wiring terminal connections are certified for a single wire in size from 12-24 AWG (0.2 to 2.5 mm² or two conductors with same cross section 0.2 to 0.75 mm²). The screws must be tightened down with a torque 4.4 - 5.3 in-lb (0.5 to 0.6 Nm). The metal housing must be electrically connected to earth ground.

A minimum of 12 Vdc must be present at the U5015 to ensure proper operation. The maximum cable length from power source to U5015 is 2000 feet (610 m). When the U5015 Smoke Detector is mounted remotely using an STB termination box, maximum cable length from U5015 to STB is 500 feet (150 m).

WARNING

For field connections, use wires/cables that are rated at 20°C greater than the maximum ambient temperature.

NOTE

In applications where the wiring is installed in conduit, dedicated conduit is

recommended. Avoid low frequency, high voltage, and non-signaling conductors to prevent nuisance EMI problems.

JUMPER

Depending on the wiring option that is used, jumpers may be required. See Table 3 for the Jumper Usage Guide and Figures 12 to 15 for wiring examples.

Table 3—Jumper Usage Guide

Wiring Option	0-20 mA		Relay	
	Used	No jumper required	Not Used	No jumper required
1	Used	No jumper required	Not Used	No jumper required
2	Used	No jumper required	Used	Jumper required in terminals 7 & 4 (P5)
3	Not Used	Jumper required in terminals 5 & 4 (P11)	Used	Jumper required in terminals 7 & 4 (P5)

WIRING PROCEDURE

Ensure that all cables are terminated properly. Conductor insulation should be stripped off with a bare conductor length of 0.28 inch (7 mm) maximum. Ensure that cable shield is properly terminated and that bare shield wire is not allowed to accidentally contact the metal housing or any other wire.

Use the following instructions when wiring the U5015 detector:

1. Slightly loosen the three setscrews located on the retaining ring (see Figure 7).



Figure 7—Setscrew Location

2. Unscrew the retaining ring to gain access to the wiring terminals (see Figure 8), and complete the installation of the system conduit. Feed the external wiring through the remaining junction box entry or M25 to 3/4 inch adapter. When installing the junction box, use care not to damage the wires and refrain from twisting them.

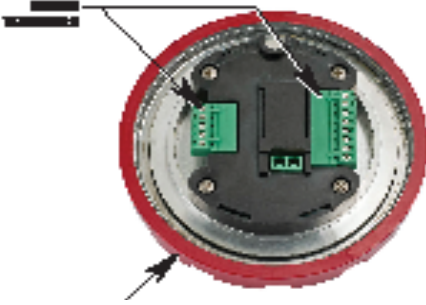

Figure 8—Location of Wiring Terminals

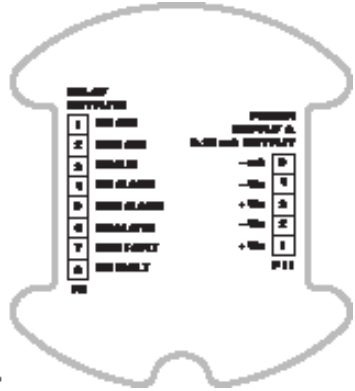

Figure 9—Wiring Terminals



Figure 10—Ground Lug Locations

3. Connect the external wiring to the appropriate terminals.
 - Figure 9 shows the wiring terminals.
 - Figure 10 shows the ground lug locations.
 - Figures 12 and 13 show wiring for single detector configurations.
 - Figures 14 and 15 show wiring for multiple detector configurations.
4. Re-install the assembly. Use the alignment guide (see Figure 11) to align the retaining ring with the junction box.
5. Screw the retaining ring on to the junction box and re-tighten the three setscrews.

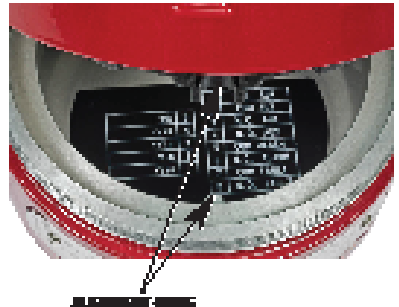

Figure 11—Alignment Guide Location

MAINTENANCE



WARNING

To avoid a potential electrostatic discharge (ESD), do not wipe or rub the surface of the U5015 sensor module.

NOTE

The U5015 Smoke Detector contains no user serviceable components and should never be opened. The U5015 wiring compartment is the only part of the smoke detector that should be opened by the user in the field.

ROUTINE INSPECTION

Regularly scheduled maintenance is not required, however, the U5015 cover and smoke chamber should be inspected periodically when detectors are located in abnormally dirty or dusty environments, to ensure the smoke chamber is not blocked by dirt or debris

The smoke detector can be tested using the same methods employed for any photo-electric detector. Det-Tronics recommends using a test aerosol smoke dispenser for periodic maintenance of the detector.

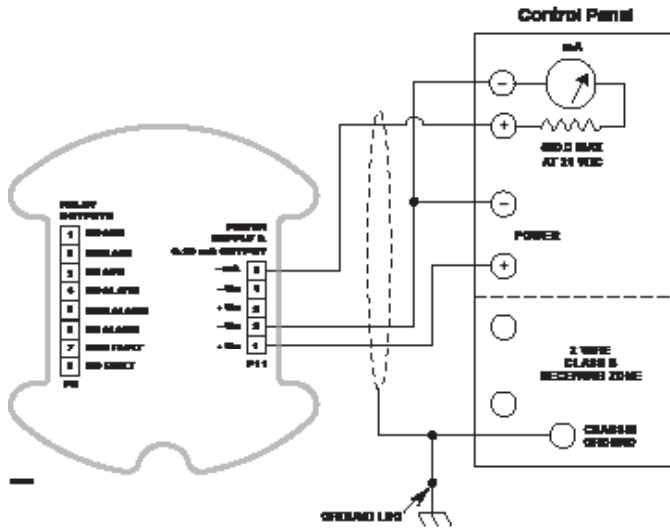

Figure 12—Single Detector Wiring (0-20 mA used, Relays not used)

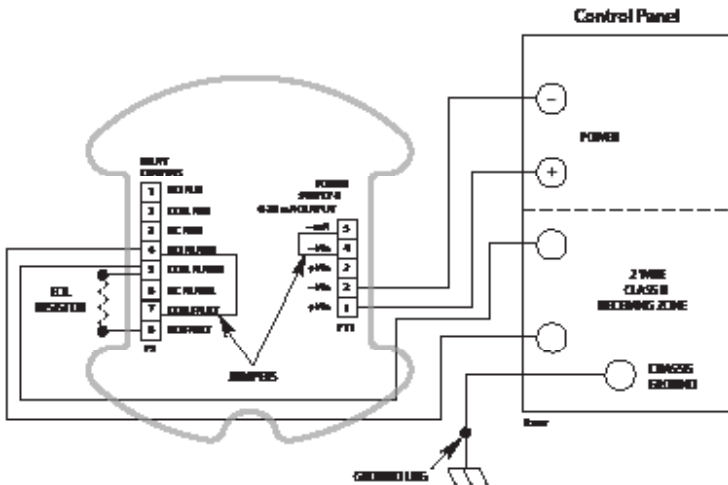

Figure 13—Single Detector Wiring (0-20 mA not used, Relays used)

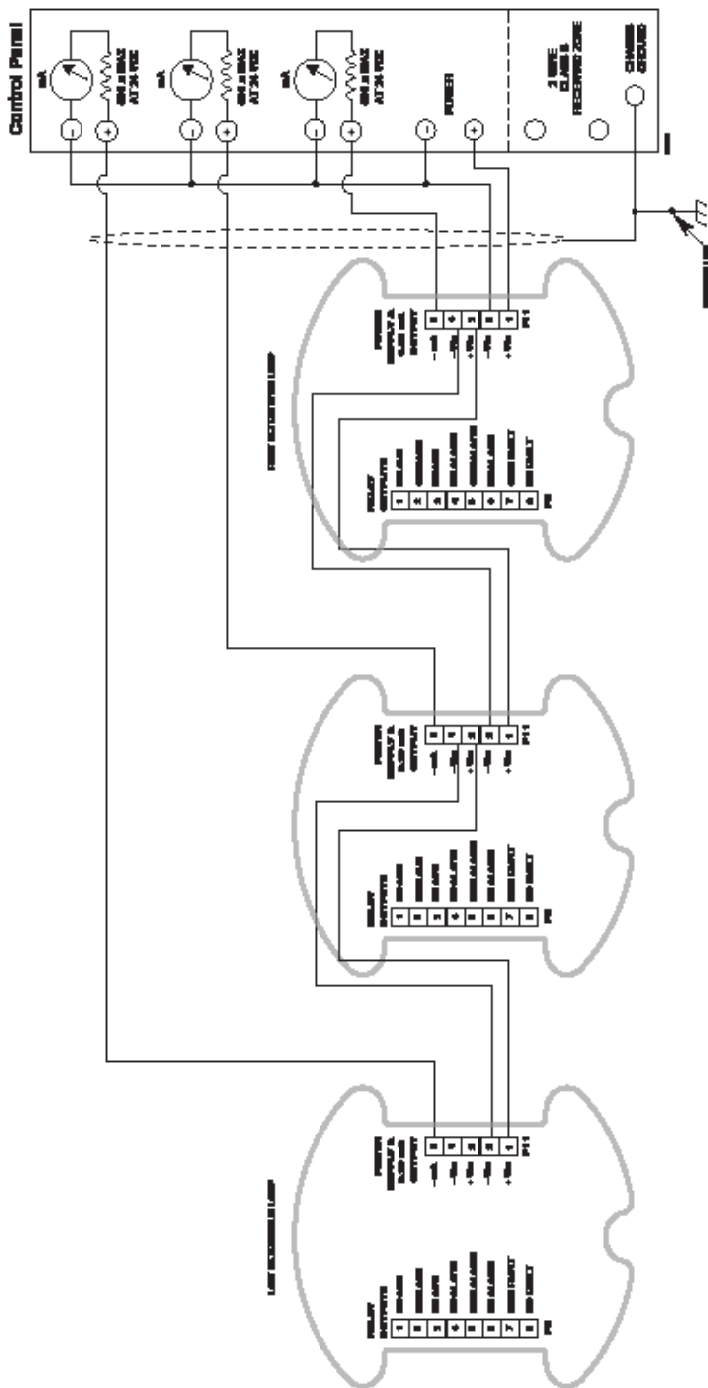

Figure 14—Multiple Detector Wiring (0-20 mA used, Relays not used)

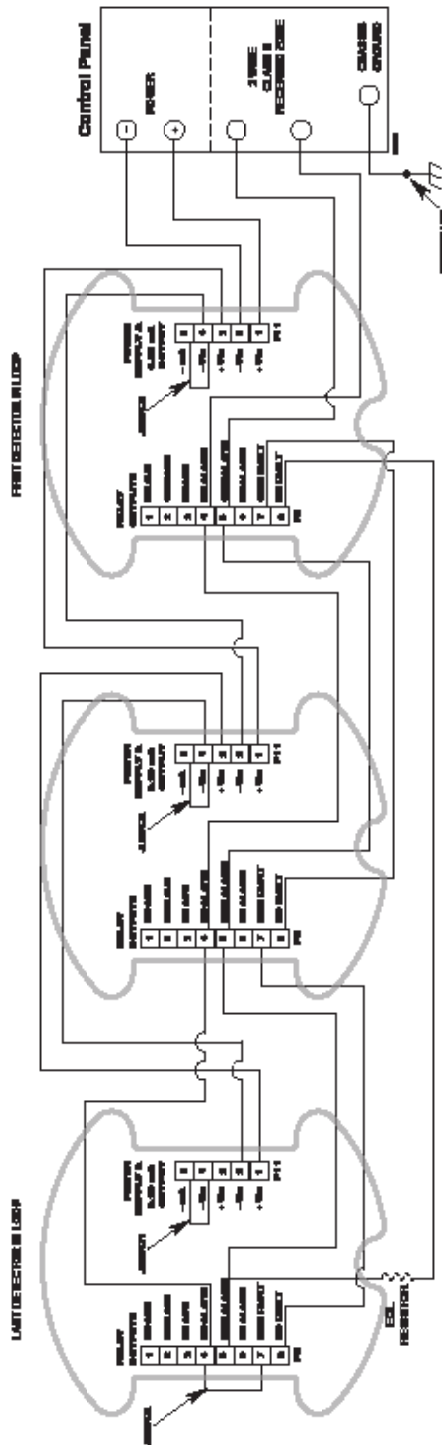

Figure 15—Multiple Detector Wiring (0-20 mA not used, Relays used)

DEVICE REPAIR AND RETURN

The sensor module is field replaceable in case of dirtiness, damage or failures incurred in the field.

The detector is not field repairable. If it has been determined that the product is faulty, then the device should be returned to the factory for repair. Details of the Det-Tronics Return Material authorization (RMA) process are available at www.det-tronics.com/technicalsupport/Pages/default.aspx

If it is determined that your material should be returned, Det-Tronics Technical Support will ask you to complete an RMA form (online or downloadable). After receipt of this form, the team will issue you a unique RMA number.

Include a copy of your RMA form inside the packaging. Please make certain to display the RMA number clearly on the outside of your packaging. Shipments received without this RMA number displayed will be refused.

Pack the unit properly, always using sufficient packing material. Wherever possible, return the product using the original Det-Tronics packing materials. Where applicable, use an antistatic bag as protection from electrostatic discharge.

NOTE

Det-Tronics reserves the right to apply a service charge for repairing returned product damaged as a result of improper packaging.

Return all equipment via transportation prepaid to the factory in Minneapolis.

ORDERING INFORMATION

When ordering, please specify:

U5015 Explosion Proof Smoke Detector

Refer to the U5015 Model Matrix for details.

SPARE PARTS

U5015 Replacement Sensor Module 104286-001

ACCESSORIES

Detector Tester (Canned Smoke)	000119-008
Canned Smoke (Spare)	000119-046
Grease (silicone-free)	005003-001
Magnet	102740-002
Magnet with Extension Pole	007739-001
Stop Plug, 3/4" NPT, AL	101197-001
Stop Plug, M25, AL	101197-005
Q5016-1 Duct Mount w/ 1 ft. tube	013901-001
Q5016-3 Duct Mount w/ 3 ft. tube	013901-003
Q5016-6 Duct Mount w/ 6 ft. tube	013901-006
Q5016-10 Duct Mt. w/ 10 ft. tube	013901-010

U5015 MODEL MATRIX

MODEL	DESCRIPTION	
U5015	Explosion Proof Smoke Detector	
	TYPE	MATERIAL
	A	Aluminum (AL)
	TYPE	# OF PORTS
	1	1 Port
	2	2 Port
	3	3 Port
	4	4 Port
	TYPE	THREAD TYPE
	N	3/4" NPT
	M	M25
	TYPE	OUTPUTS
	12	0-20 mA, Relay, Non-Latching
	13	0-20 mA, Relay, Latching
TYPE	APPROVAL	
A	FM/IECEX/CSA	
C	CSA	
F	FM/IECEX	
R	VNIIFTRI (Russia)	

APPENDIX A

FM APPROVAL DESCRIPTION

U5015

Class 1 Div 1 Groups B, C, D T4
Class 1 Div 2 Groups A, B, C, D T4
Class 1 Zone 1 AEX db ia IIC T4 Gb
Tamb -20°C to +65°C
IP44

Q5016 Duct Mount Accessory

ANSI/UL 268A: 4th Edition Standard for Smoke Detectors for Duct Applications (only when installed on the vertical surface of the duct)

Applicable Documents:

FM 3810: 2005	Elec. and Electronic Test, Measuring, and Process Control Equipment
FM 3600: 2011	Electrical Equipment for use in Hazardous (Classified) Locations
FM 3610: 2010	Intrinsically Safe, Class I, II, III, Div I, Haz. Loc.
FM 3611: 2004	Elec. Equip. for use in Cl. I/II, Div. 2 and Cl. III, Div. 1/2 Haz. Loc.
FM 3615: 2006	Explosion proof Electrical Equipment
FM 3230: 2010	Smoke actuated detectors for automatic alarm signaling
ANSI/ISA 1010-1: 2004	Safety Requirements for Electrical Equipment for Measurement, Control, and Laboratory Use – Part 1: General Requirements
ANSI/IEC 60529: 2004	Degrees of Protection Provided by Enclosures (IP Code)
ANSI/ISA 60079-0: 2013	Explosive atmospheres – Part 0: Equipment – General Requirements
ANSI/ISA 60079-1: 2013	Explosive atmospheres – Part 1: Equipment protection by Flameproof Enclosures “d”
ANSI/ISA 60079-11: 2014	Explosive atmospheres – Part 11: Equipment protection by intrinsic safety “i”

Special Conditions For Safe Use X:

1. The U5015 is to be installed in locations where the risk of mechanical damage is low.
2. Potential electrostatic charging hazard please see instructions for proper installation.
3. All unused device openings must be closed using a suitably certified plug.
4. For field connections, use wire rated 20°C greater than maximum ambient temperature.
5. For AEx d rated Model U5015 Smoke Detector, the flameproof joints are not allowed to be repaired per manufacturer's instruction manual.
6. The U5015 shall be used with the Q5016 Duct Mount Accessory for duct mount installations.

APPENDIX B

CSA APPROVAL DESCRIPTION

U5015

Class - C481804 - Signal Appliances - Systems - For Hazardous Locations
Ex db ia IIC T4 IP44

Applicable Requirements

C22.2 No. 0-M91	General requirements - Canadian Electrical Code, Part II
C22.2 No. 60529: 2015	Degrees of protection provided by enclosures (IP Code).
C22.2 No. 610101-1: 2012	Safety requirements for electrical equipment for measurement, control, and laboratory use - Part 1: General Requirements.
C22.2 No. 60079-0: 2015	Electrical apparatus for explosive gas atmospheres - Part 0: General Requirements
C22.2 No. 60079-1: 2016	Explosive atmospheres - Part 1: Equipment protection by flameproof enclosures "d".
C22.2 No. 60079-11: 2014	Electrical apparatus for explosive gas atmospheres - Part 11: Intrinsic Safety "i".

Special Conditions For Safe Use X:

1. Field wiring must be in accordance with CEC Part 1, Section 18.
2. The enclosure must be bonded to ground according to CEC Part 1, Section 18.
3. For enclosures with metric conduit entries certified metric to NPT adaptors shall be used.
4. All unused openings must be closed using suitably certified plugs.
5. A seal shall be installed within 18" of enclosure.
6. Measures must be taken to avoid ignition due to mechanical impact.
7. IPx4 maintained only when mounted on a ceiling.

APPENDIX C

IECEX APPROVAL DESCRIPTION

U5015

IECEX FMG15.0014X

Ex db ia IIC T4 Gb

Tamb -20°C to +65°C

IP44

IEC Standards:

IEC 60079-0: 2011 Electrical apparatus for explosive atmospheres, General Requirements

IEC 60079-1: 2014 Electrical apparatus for explosive atmospheres, Flameproof enclosure "d"

IEC 60079-11: 2011 Intrinsic Safety explosive atmospheres Equip protection by Intrinsic Safety

Special Conditions For Safe Use X:

1. The U5015 is to be installed in locations where the risk of mechanical damage is low.
2. Potential electrostatic charging hazard please see instructions for proper installation.
3. All unused device openings must be closed using a suitably certified plug.
4. For field connections, use wire rated 20°C greater than maximum ambient temperature.
5. For AEx d rated Model U5015 Smoke Detector, the flameproof joints are not allowed to be repaired per manufacturer's instruction manual.

APPENDIX D

ADDITIONAL APPROVALS

RUSSIA & KAZAKHSTAN



VNIIFTRI

CERTIFICATE OF CONFORMITY TO TP TC 012/2011

No. TC RU C-US. BH02.B.00239

1Exd[ia]IICT4 IP44

T4 (Tamb = -20°C to +65°C)

Declaration of Conformity to TP TC 020/2011 (EMC)

EA3C No. RU д-US.PA01.B.50006

RUSSIA



VNIIPO

CERTIFICATE OF CONFORMITY TO TECHNICAL REGULATIONS, GOST R 53325-2012

C-US.цC13.B.00192



95-8723



FlexSonic® Acoustic
Leak Detector



X3301 Multispectrum
IR Flame Detector



PointWatch Eclipse® IR
Combustible Gas Detector



FlexVu® Universal Display
with GT3000 Toxic Gas Detector



Eagle Quantum Premier®
Safety System

Specifications subject to change without notice.

All trademarks are the property of their respective owners.
© 2020 Detector Electronics Corporation. All rights reserved.

Det-Tronics manufacturing system is certified to ISO 9001—
the world's most recognized quality management standard.



Corporate Office
6901 West 110th Street
Minneapolis, MN 55438 USA
www.det-tronics.com

Phone: 952.941.5665
Toll-free: 800.765.3473
Fax: 952.829.8750
det-tronics@carrier.com