



CHARACTERISTIC / CARATTERISTICHE	
Volt	12V
Capacity / Capacità	20h 55Ah
	5h 48Ah
Internal Resistance	Full Charged Battery 25°C ≤5.8mΩ
Capacity affected by Temperature / Effetti delle temperature sulla capacità	40°C 102%
	25°C 100%
	0°C 85%
	-15° 65%
Self-Discharge 25°C Capacity / Autoscarica a 25°C	after 3 month storage 90%
	after 6 month storage 80%
	after 12 month storage 62%
Charge (Costant Voltage 25°C)	Float Volt 13.6 - 13.8V
	Charge Max. 16.5Amp. 14.4 - 15 Volt

CHARACTERISTIC / CARATTERISTICHE			
Battery dimensions / Dimensioni batteria			
L/L	W/P	H/A	Tot - H/A
230	138	210	215
Box Dimensions / Dimensioni scatola			
L/L	W/P	H/A	
-	-	-	
Weight / Peso		17.30Kg	
Terminal / Terminali		M6	
Case / Contenitore		ABS	

Amp. (25°C)

F.V/Time	5min	10min	15min	30min	45min	1h	2h	3h	5h	8h	10h	20h
1.60V		129	99.4	59.2		35.1		14.6	9.82		5.75	2.94
1.65V		124	95.4	57.4		34.2		14.2	9.57		5.70	2.93
1.70V		115	90.6	55.6		33.3		13.9	9.40		5.65	2.92
1.75V		106	85.8	53.8		32.5		13.6	9.23		5.60	2.90
1.80V		99.8	79.5	51.9		31.7		13.3	9.06		5.50	2.88

Watts (25°C)

F.V/Time	5min	10min	15min	30min	45min	1h	2h	3h	5h	8h	10h	20h
1.60V		238	185	111	85.3	68.9	41.1	29.1	18.8			
1.65V		225	177	109	84.0	67.3	40.2	28.5	18.6			
1.70V		213	169	107	82.3	65.8	39.4	27.9	18.2			
1.75V		200	162	105	80.5	64.3	38.4	27.3	18.0			
1.80V		186	154	104	78.4	62.6	37.4	26.7	17.9			

ZGL120058

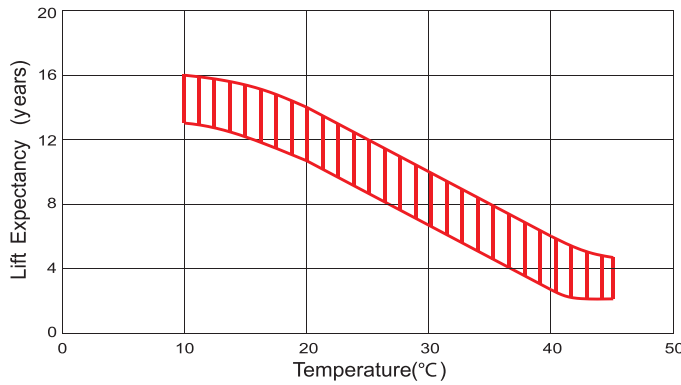
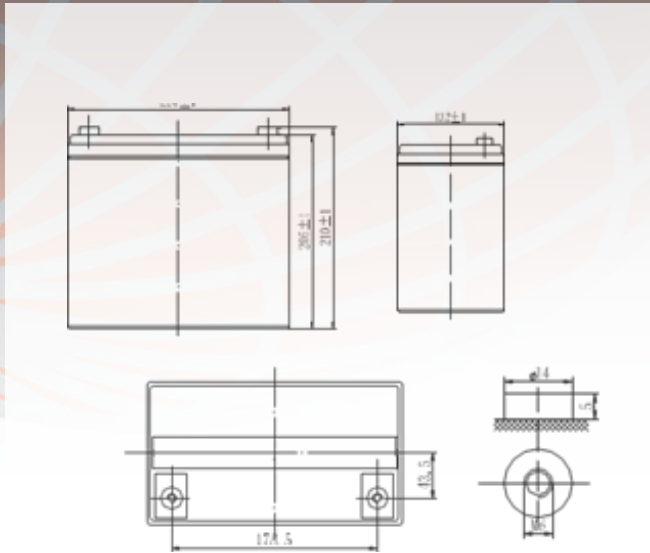

Charging characteristics

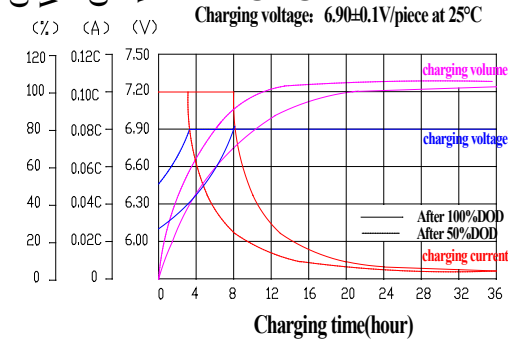

Temperature effect on battery self-discharge

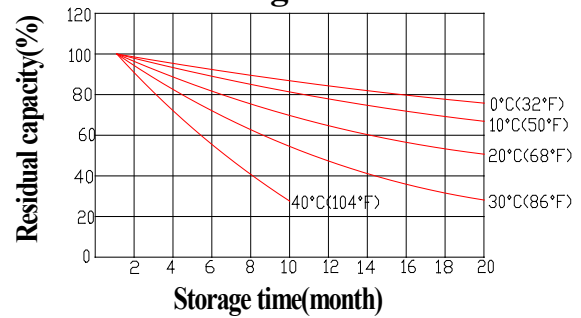

Discharge characteristics (25°C)

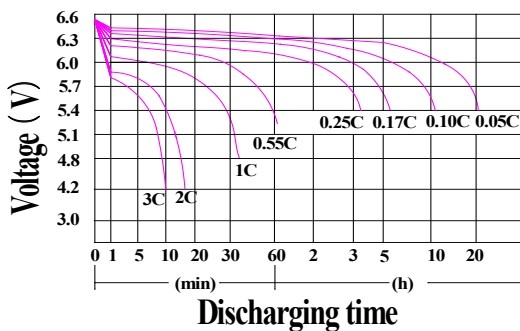

Temperature effect on capacity

